

BEST BOX

COLLECTION TANK

Garage, Wash basin, Shower

Prefabricated, robust lift stations.

APPLICATIONS

- **Best Box G (Garage model)**
Lifting rainwater, from wash areas, garage downramps, etc.
- **Best Box L (Wash basin model)**
Lifting domestic and bathroom water (basin, dishwasher, washing machine)
- **Best Box D (Shower model)**
Particularly suited to shower water, does not need to be installed underground with the tank inlet located 90 mm from the base and a check device

TECHNICAL FEATURES

- Quick, easy installation
- Robust, compact construction
- Available with/without electric pump

TECHNICAL DATA

Tank

- Model G (Garage): High strength PVC grille
- Model L (Wash basin): cover with overflow vent
- Model D (Shower): cover with overflow vent
- Tank capacity: 30 litres
- Tank weight: 7 kg (BEST BOX L and BEST BOX D), 10 kg (BEST BOX G)

Electric pump (selected models)

- BEST BOX G can be equipped with the BEST ONE VOX (vortex impeller) electric pump, with float switch for automatic operation
- BEST BOX L and BEST BOX D can be equipped with the BEST ONE pump with float switch for automatic operation. BEST BOX L is configured to receive water from above, while BEST BOX D receives water from below
- 5 metre cable + standardised plug
- 2800 rpm
- Single phase voltage: 230V +/- 10%
- Insulation class F
- Protection rating IP68
- Maximum fluid temperature: 50°C
- Maximum solid passage: 10 mm BEST ONE
20 mm BEST ONE VOX

MATERIALS

Tank

- High density polyethylene

Electric pump (selected models)

- AISI 304 stainless steel construction throughout
- Mechanical seal as standard supply

For the technical data of the BEST ONE/ BEST ONE VOX pumps (see page 5)



BEST BOX G



BEST ONE VOX



BEST BOX D



BEST ONE

PERFORMANCE CURVES (per ISO 9906 Annex A)

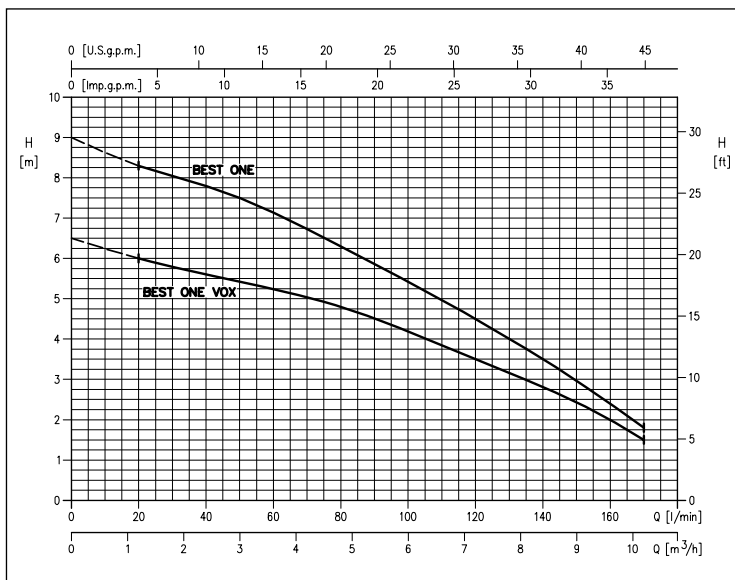

BEST BOX

COLLECTION TANK

Garage, Wash basin, Shower

DIMENSIONS BEST BOX G

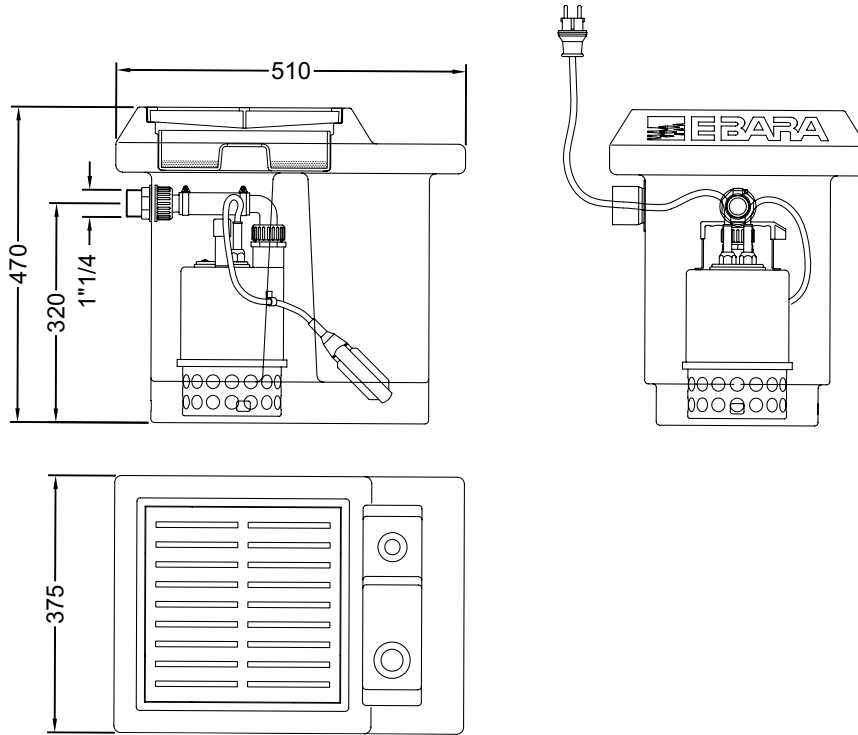

DIMENSIONS BEST BOX L

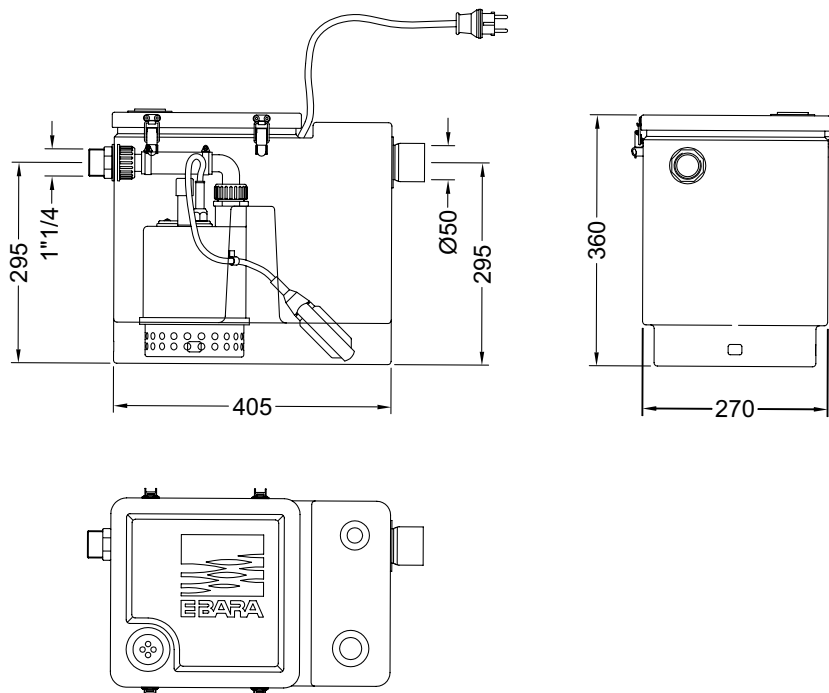

The contents of this publication should not be regarded as binding. EBARA Pumps Europe S.p.A. reserves the right to effect any modification it deems necessary, without prior notice.



BEST BOX

COLLECTION TANK

Garage, Wash basin, Shower

DIMENSIONS BEST BOX D

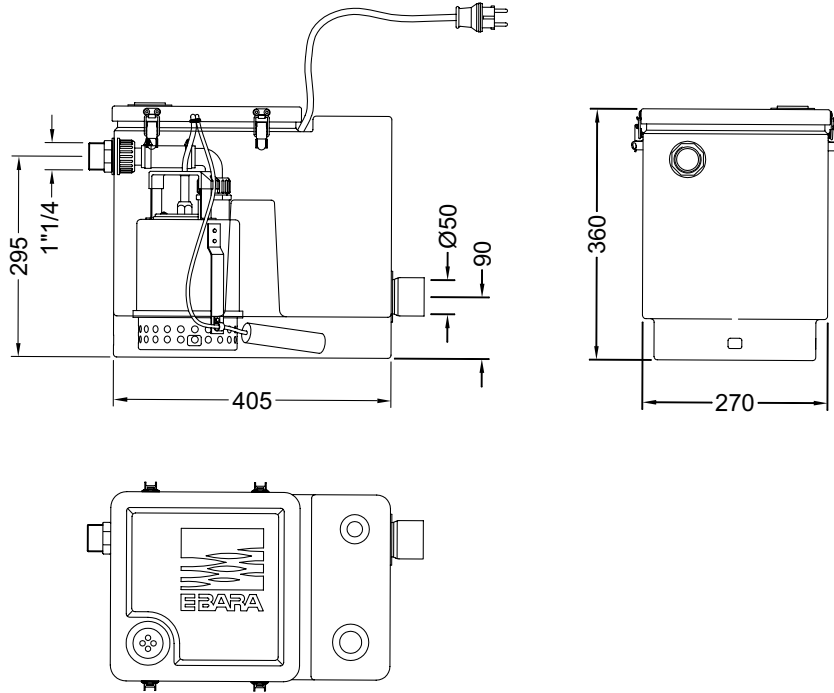

The contents of this publication should not be regarded as binding. EBARA Pumps Europe S.p.A. reserves the right to effect any modification it deems necessary, without prior notice.

BEST BOX

COLLECTION TANK

Garage, Wash basin, Shower

TECHNICAL SPECIFICATIONS

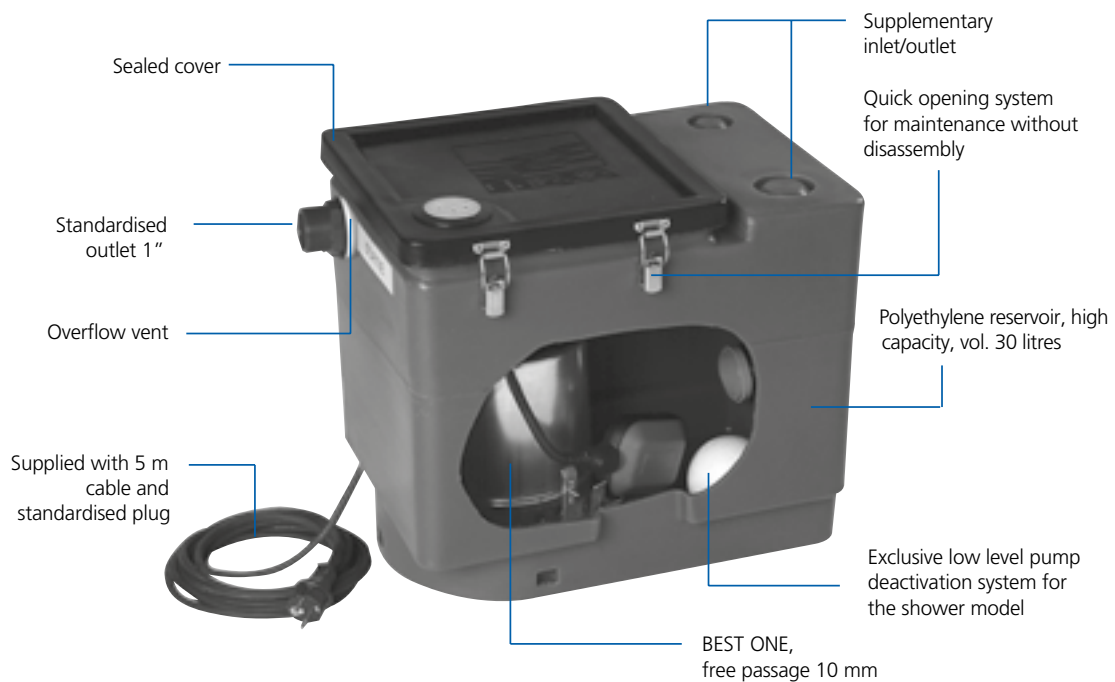

The contents of this publication should not be regarded as binding. EBARA Pumps Europe S.p.A. reserves the right to effect any modification it deems necessary, without prior notice.