



# CABINET BOOSTER

[www.motralec.com](http://www.motralec.com) / [service-commercial@motralec.com](mailto:service-commercial@motralec.com) / 01.39.97.65.10

EBARA Pumps Europe S.p.A. presents the innovative booster set (constant pressure) for civil and industrial uses, with EBARA pumps and pipe in stainless steel. CABINET BOOSTER is set for revolutionize the actual applications and pumping solutions. Suitable for domestic water supply, pumping water or increasing pressure in general, horticultural irrigation and small industrial water supply systems, in particular for Building Service applications.

**Cabinet Booster** is a booster unit with two pumps in parallel, in which a pump is supplied by frequency converter (inverter), the second pump acts to full motor speed. The two pumps, the hydraulic components (fittings, manometer, ball and check valves, expansion vessel), the mechanical system of anchorage and the electric panel of command are all contents in an single cabinet (box) in sheet metal. The **Cabinet Booster** is proper for the installation to embedding on wall and wall- floor installation, it results a more centralized and more compact system, compared to the common booster units.

- 1 Easy installation
- 2 Fast plant execution
- 3 Reduced space for the installation
- 4 Silent Easy maintenance and plant cleaning
- 5 Silent
- 6 Wall built-in version
- 7 Save energy (inverter functioning)
- 8 Easy data input
- 9 Versatile (six models available)
- 10 EBARA in line pumps: pumped liquid-cooled

Multigo in line pumps with oval flanges

Floor anchorage system

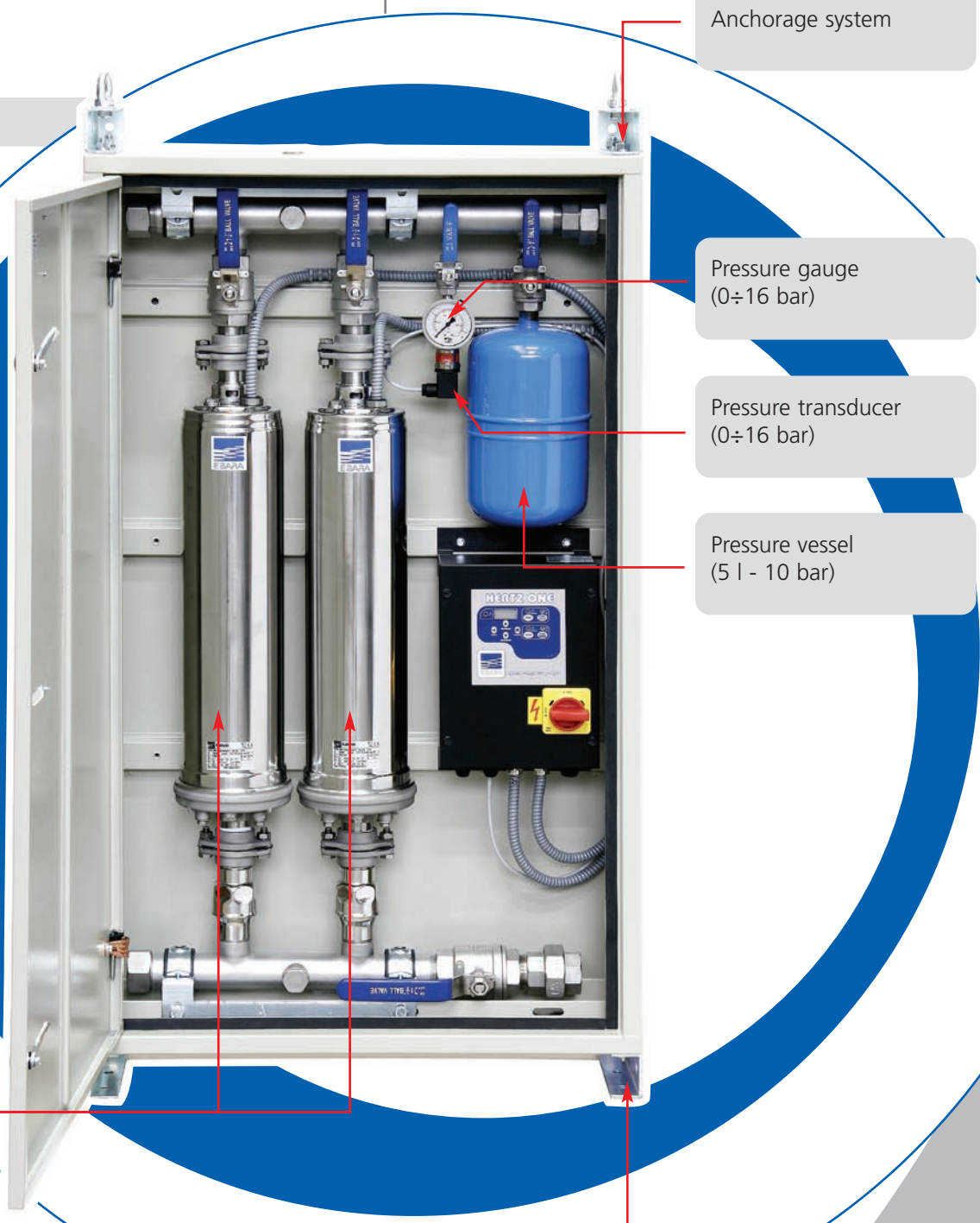

- Anchorage system
- Pressure gauge (0÷16 bar)
- Pressure transducer (0÷16 bar)
- Pressure vessel (5 l - 10 bar)

## HERTZ ONE MINI INVERTER CONTROL BOX



- Save energy
- Fast regulation
- Water hammer reduction
- Low sound level
- Easy input data

## PERFORMANCE CURVES: 40 SERIES (1 AND 2 PUMPS)

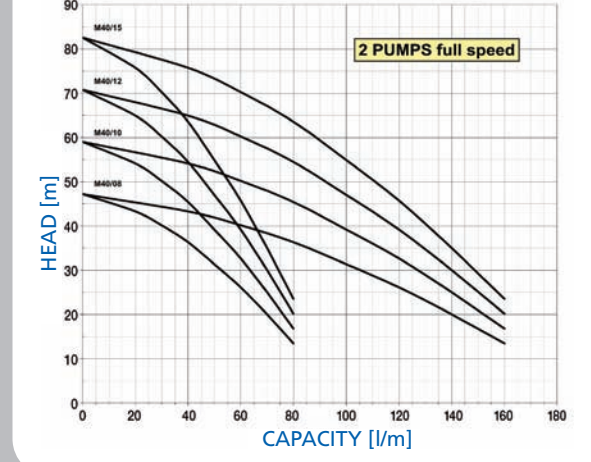
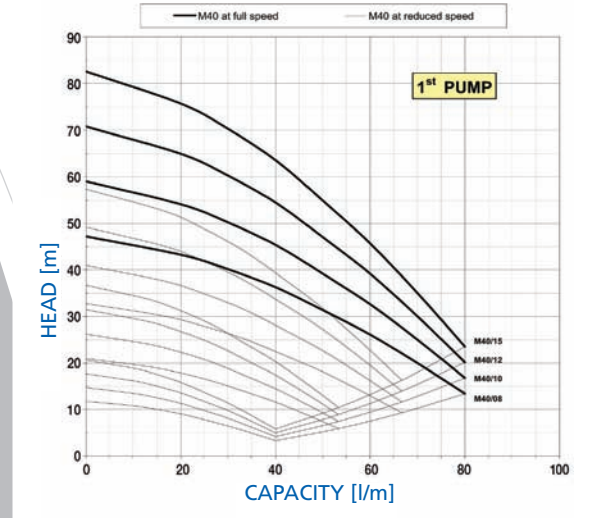

## PERFORMANCE CURVES: 80 SERIES (1 AND 2 PUMPS)

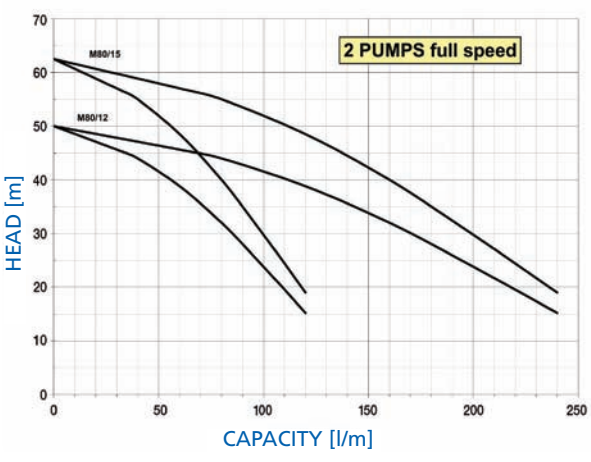
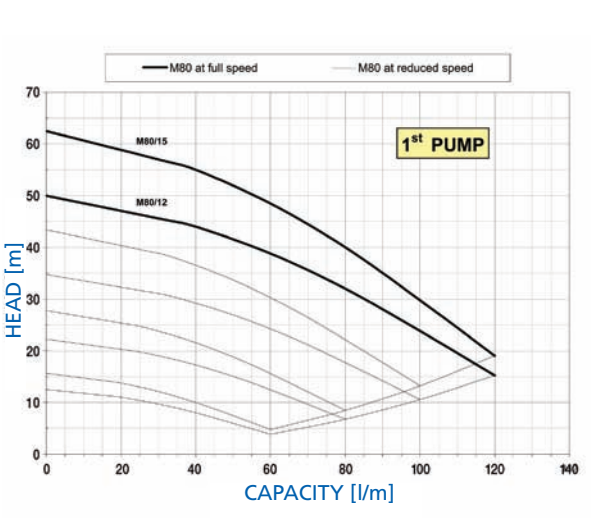

## MULTIGO IN LINE PUMP SCHEME

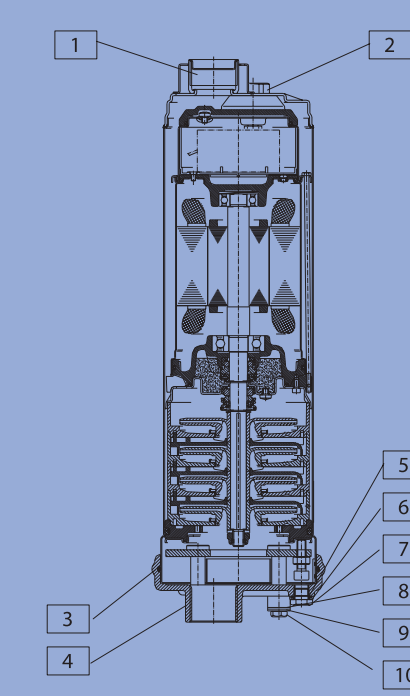

- 1 Discharge 1" 1/4
- 2 Breather plug
- 3 O ring
- 4 Suction flange 1" 1/4
- 5 O ring
- 6 Washer
- 7 Drain plug
- 8 O ring
- 9 Washer
- 10 Screw

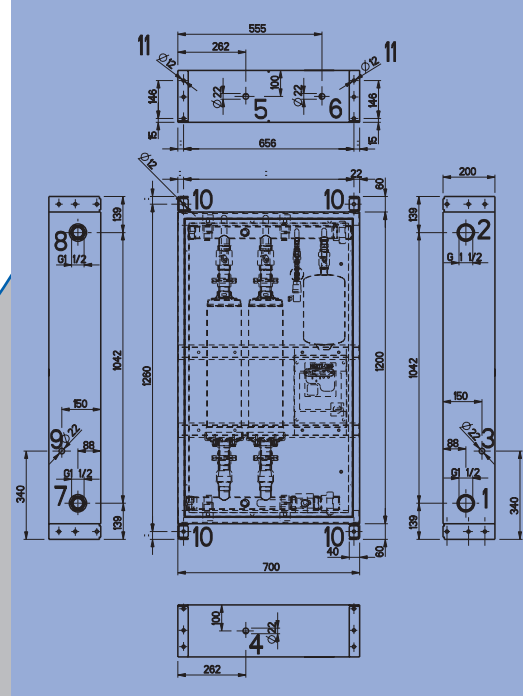

- 1 Water inlet from the left (G1½)
- 2 Water outlet from the left (G1½)
- 3 Cable entry from the left (PG16)
- 4 Cable entry from the top (PG16)
- 5 Cable entry from the bottom (PG16)
- 6 Cable entry from the bottom (PG16)
- 7 Water inlet from the right (G1½)
- 8 Water outlet from the right (G1½)
- 9 Cable entry from the right (PG16)
- 10 Vertical anchor bores
- 11 Horizontal anchor bores



**CABINET BOOSTER**

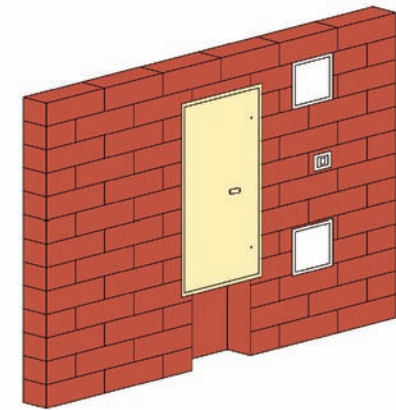
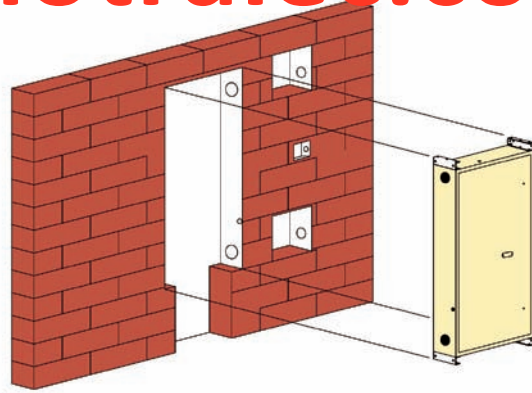

**ANCHORAGE TO THE FLOOR / WALL**

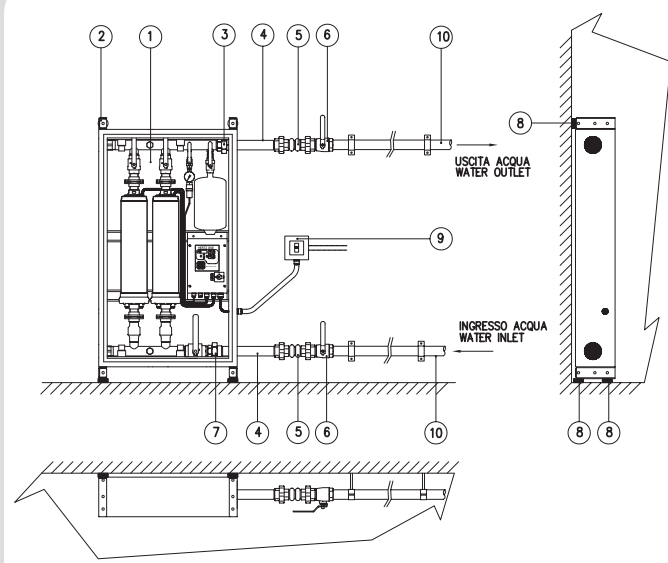
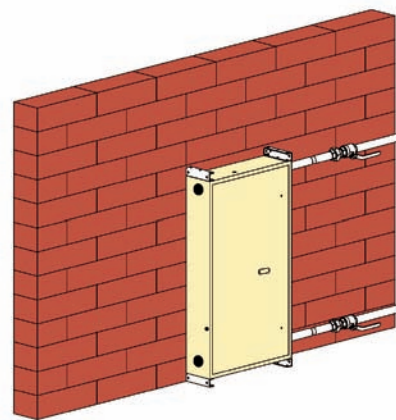

**SPECIFICATIONS**

- 1 Booster cabinet
- 2 Anchor feet
- 3 Conical union female-female
- 4 Pipe 1" 1/2
- 5 Rubber expansion joint
- 6 Isolating valve
- 7 Conical union male-female
- 8 Vibration damping supports
- 9 Disconnecting switch
- 10 Net piping

[www.ebara.eu](http://www.ebara.eu)



EBARA PUMPS EUROPE S.p.A.  
Via Pacinotti, 32  
36040 BRENDOLA (VICENZA), Italy  
Phone: +39-0444-706811  
Fax: +39-0444-706950  
Plants: Cles, Brendola  
[marketing@ebara.eu](mailto:marketing@ebara.eu)  
[www.ebara.eu](http://www.ebara.eu)

cod. 479705380 REV 02/06



**CABINET BOOSTER**



**EBARA**

**Innovative single phase booster set  
(inverter control)**

**NEW**

EBARA PUMPS EUROPE S.p.A. reserves the right to make modifications without prior notice; all specifications could be subject to change