



**ITT**

**Water & Wastewater**

# Flygt Compact C Range



*Engineered for life*

“A competitively priced progressing cavity pump, with a compact construction and maximum performance characteristics.”

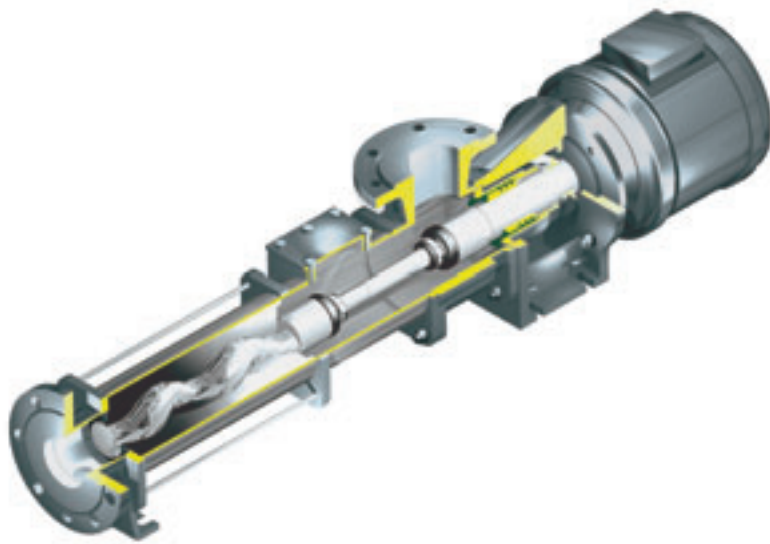

Waste water pumping

### Features & Benefits

Capacity	up to 225m <sup>3</sup> /h
Pressure	up to 24 bar
Temperature	-10°C up to 100°C

### Typical applications include:

- Hydrated lime slurry
- Sludge

#### Handles gas entrainment

No air or gas locking in the pump. The positive seal formed by the interference fit between rotor and stator enables the pump to self prime and it also allows tri-phase liquids i.e. solids, gases and liquids to be handled easily.

#### Robust drives

Specially selected drives and gear-boxes for longer life. Options include electric motor drive units supplied as overhead vee belt driven, direct-coupled or variable speed drives with mechanical variable speed or frequency inverter.

#### Low running speeds

Reduced wear for a longer working pump life which extends the periods between routine maintenance. Think of the savings you could make on abrasive applications.

#### High pressure

Long haul pumping can offer considerable project cost savings by utilising small bore pipework and eliminating the need for a series of pumps, when pumping over long distances or with high head requirements.

#### Materials of construction

Available in cast iron or stainless steel, with a choice of rotor and stator materials to suit individual applications e.g. hard chrome plated rotor or natural rubber stator.

#### Versatile

Can be installed vertically or horizontally to suit the application. Can be run in either direction.

#### Baseplate

Pumps are supplied on a baseplate to ease installation.

#### Inspection cover

Available for applications where rag content is a problem.

#### Gentle pumping action

Minimises shear and crush damage to the pumped product.

#### Viscous products

The pump can be supplied with a square inlet and conveyor to assist viscous slurries into the pumping element.

#### Plug in shaft

Ease of maintenance when assembling or dismantling, with extraction facility.

#### Sealed joints

Fully sealed drive train to maximise life and minimise downtime.

#### Duracoat coating

Rotors can be supplied with Flygt's range of specialist coatings to help extend the life of the rotors by increasing wear and corrosion resistance

#### Shaft sealing options

Packed gland or single and double mechanical seals are available.

#### Surface mounted

Making it easier, cleaner and less hazardous for maintenance.

#### Compact unit

As the drive forms an integral part of the unit, the pump is ideal for space-saving installations.

#### Up to 8.5m suction lift

Deep sumps can be easily pumped without the use of submersible equipment.

# Performance data



Pumping of slurry mix

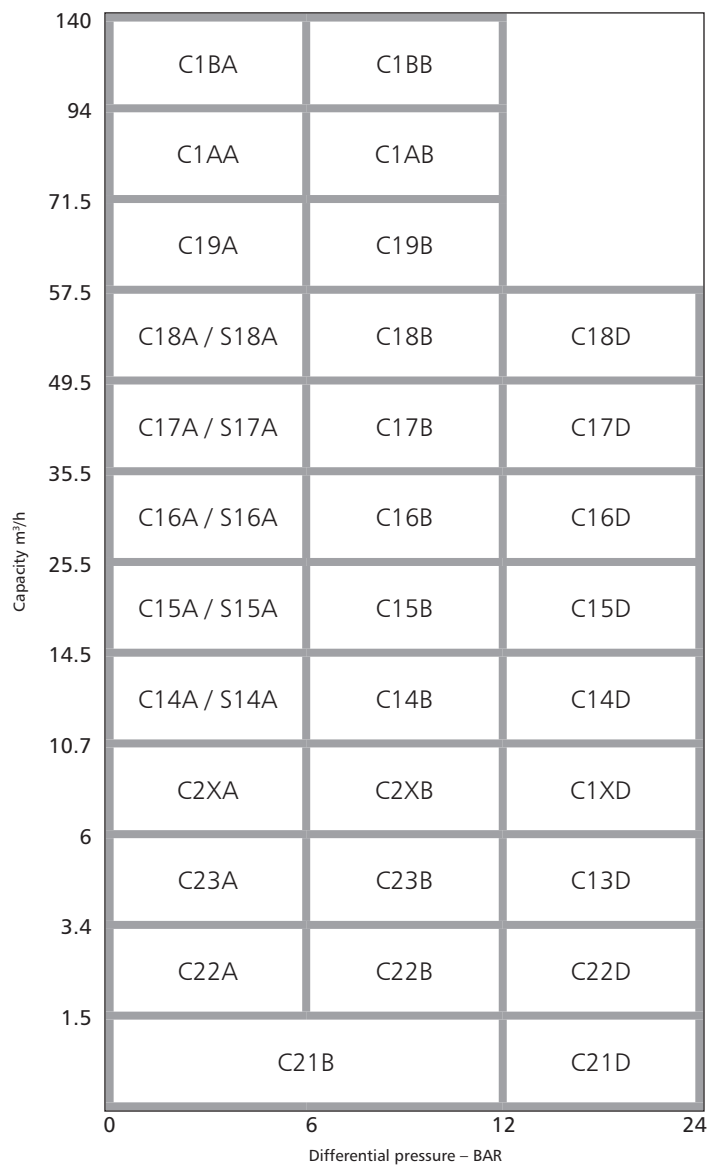
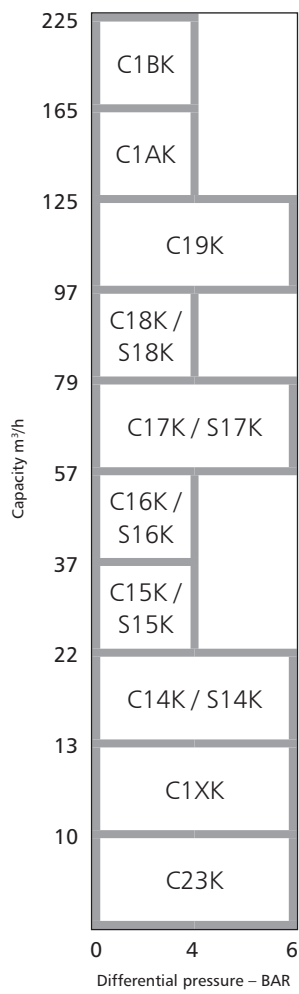

For guidance in selecting a pump, please contact ITT Water & Wastewater.

# Product dimensions



Transfer of polymer for Waste Water

MODEL	A	A1	B	C	D	E	F	G	H
C21B	429	115	296	133	1 1/4"	144	85	120	160
C21D	573	250	440	133	1 1/4"	144	85	120	160
C22A	429	115	296	133	1 1/4"	144	85	120	160
C22B	573	250	440	133	1 1/4"	144	85	120	160
C22D	959	525	822	137	1 1/2"	148	85	120	160
C23A	520	165	383	137	1 1/2"	148	85	120	160
C23B	665	300	528	137	1 1/2"	148	85	120	160
C23K	665	300	528	137	1 1/2"	148	85	120	160

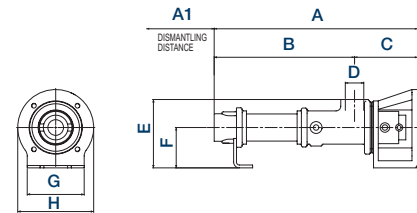

MODEL	A	A1	B	C	D	E	F	G	H
C1XK	750	300	593	157	50	190	85	120	160
C14K	986	455	756	230	65	227	112	140	200
C15K	1102	570	882	220	80	232	112	140	200
C16K	1272	680	1036	236	100	255	125	160	250
C17K	1478	800	1198	281	125	310	150	180	300
C18K	1654	880	1374	280	125	310	150	180	300
C19K	1856	990	1541	315	150	345	160	200	300
C1AK	2007	1100	1692	315	150	345	160	200	300
C1BK	2437	1210	2009	427	200	450	225	280	350
C13D	1160	525	930	230	65	227	112	140	200
C2XA	566	135	409	157	50	190	85	120	160
C2XB	749	315	592	157	50	227	112	120	160
C1XD	1363	650	1086	277	80	245	125	160	250
C14A	781	250	551	230	65	227	112	140	200
C14B	986	455	756	230	65	227	112	140	200
C14D	1462	780	1185	277	80	245	125	160	250
C15A	842	310	622	220	80	232	112	140	200
C15B	1159	570	882	277	80	245	125	160	250
C15D	1776	1005	1457	319	100	280	150	180	300
C16A	960	365	724	236	100	255	125	160	250
C16B	1355	680	306	319	100	280	150	180	300
C16D	2181	1210	1813	369	125	320	160	200	300
C17A	1110	430	830	281	125	310	150	180	300
C17B	1478	800	1198	281	125	310	150	180	300
C17D	2626	1385	2224	402	150	410	225	280	350
C18A	1246	475	966	281	125	310	150	180	300
C18B	1742	880	1374	386	125	320	160	200	300
C18D	2786	1555	2384	402	150	410	225	280	350
C19A	1394	530	1079	315	150	345	160	200	300
C19B	1856	990	1541	315	150	345	160	200	300
C1AA	1476	610	1161	315	150	345	160	200	300
C1AB	2159	1100	1756	402	150	410	225	280	350
C1BA	1794	640	1366	427	200	450	225	280	350

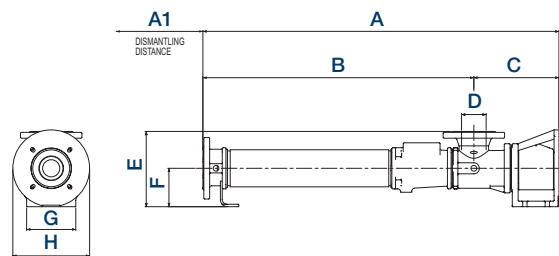

MODEL	A	A1	B	C	D	E	F	G	H
S14A	781	250	526	255	165x165	236	112	140	200
S14K	986	455	731	255	165x165	236	112	140	200
S15A	842	310	587	255	165x165	236	112	140	200
S15K	1102	570	847	255	165x165	236	112	140	200
S16A	960	365	674	286	200x200	260	125	160	250
S16K	1272	680	986	286	200x200	260	125	160	250
S17A	1110	430	777	333	240x240	310	150	180	300
S17K	1478	800	1145	333	240x240	310	150	180	300
S18A	1246	475	912	334	240x240	310	150	180	300
S18K	1654	880	132	334	240x240	310	150	180	300

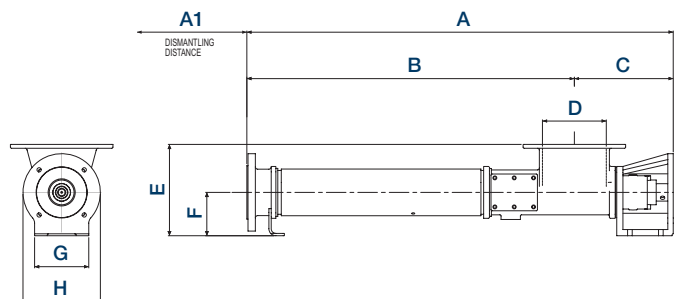

# Motor/baseplate dimensions

MODEL	LENGTH	WIDTH	HEIGHT
C1XK	1304	300	304
C14K	1665	300	475
C15K	1777	360	475
C16K	1947	360	488
C17K	2464	360	609
C18K	2640	420	609
C19K	2902	420	649
C1AK	3053	420	649
C1BK	3481	520	537
C13D	1835	360	475
C2XA	1120	300	304
C2XB	1329	300	304
C1XD	2038	420	488
C14A	1456	300	475
C14B	1665	300	475
C14D	2137	360	488
C15A	1517	300	475
C15B	1834	360	488
C15D	2762	420	609
C16A	1635	360	488
C16B	2341	420	609
C16D	3225	520	472
C17A	2066	360	584
C17B	2464	360	609
C17D	3672	520	727
C18A	2202	360	584
C18B	2788	420	649
C18D	3830	520	537
C19A	2440	420	649
C19B	2902	420	649
C1AA	2522	420	649
C1AB	3205	520	727
C1BA	2840	520	727

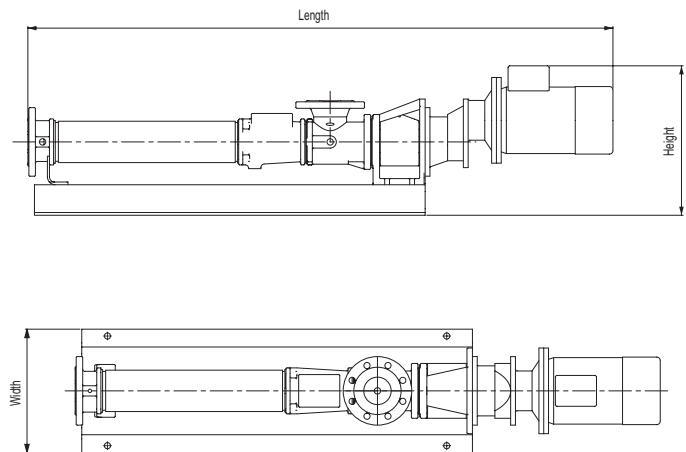

All dimensions in mm's and refer to the largest selected drive.  
Dimensions are for guidance only, for full certified drawings,  
please contact ITT Water & Wastewater.

MODEL	LENGTH	WIDTH	HEIGHT
C21B	984	300	304
C21D	1149	300	304
C22A	984	300	304
C22B	1149	300	304
C22D	1544	300	304
C23A	1084	300	304
C23B	1234	300	304
C23K	1234	300	304

MODEL	LENGTH	WIDTH	HEIGHT
S14A	1456	300	475
S14K	1665	300	475
S15A	1517	300	475
S15K	1777	360	475
S16A	1635	360	488
S16K	1947	360	488
S17A	2066	360	584
S17K	2464	360	609
S18A	2202	360	584
S18K	2640	420	609

# Here's how we complete the picture

## Flygt monitoring and control improves the uptime of your wastewater treatment plant leading to lower operational costs.

We supply both the hardware and the software for complete process systems – ranging from SCADA, process and pump controllers to pump drives, start equipment and sensors through to system software. With smart monitoring and control, you benefit from predictive maintenance. Our system automatically alerts you at an early stage when service is required, and signaling when corrective actions are necessary. This effectively eliminates unnecessary emergency service calls and cuts both operating and maintenance costs.

And Flygt Monitoring & Control is easy to use. Settings can be changed quickly by simply adjusting the values on the display on the controller, on the central system or even on a laptop from wherever a user happens to be.



## Your worldwide service network



Because no two pumping stations or systems are alike, ITT Water & Wastewater lets you choose the type of support package that best matches your needs. At one end, we help in selecting the right pump for a new application. At the other end, we can provide full service assistance that includes everything from system planning and design, through construction and commissioning, to operation and maintenance.

### **Extensive spare parts guarantee**

With a worldwide network of authorized service centers, you always get the support you need: whether it's a question of planned maintenance or express part delivery.

We also guarantee the availability of spare parts 20 years after we stop production of a pump model. This is just one of the ways we demonstrate our long-term commitment to our customers.