

BMS

BMS hs, BMS hp, BMST, BMSX

Pressure boosting and reverse osmosis systems

50/60 Hz



1. Product introduction	4
Grundfos BMS hs.....	4
Grundfos BMS hp	4
2. Performance range	5
BMS hs PM booster system.....	5
BMS hs AC booster system.....	5
BMS hp MG/MGE booster system.....	6
3. General description, BMS hs and BMS hp	7
Type key	7
Pumped liquids	7
Curve conditions	7
Parallel operation.....	7
Flushing	7
Filtration	7
Automatic control devices	8
Automatic safety devices.....	8
4. Grundfos BMS hs	9
Applications	9
Standard pumps.....	9
Operating limits	9
Operating conditions	10
Construction.....	10
Motor types	10
Frequency converter for PM motor	11
5. Grundfos BMS hp	15
Applications	15
Standard pumps.....	15
Operating limits	15
Motor	16
Operating conditions	16
6. High pressure booster systems	17
BMS hs booster system.....	17
BMS hp booster system.....	17
7. Reverse osmosis systems	18
BMS hs system	18
BMST system.....	18
BMSX system	19
8. Features and benefits	20
BMS hs booster system.....	20
BMS hp booster system.....	21
9. Product range	22
BMS hs PM booster system and frequency converter.....	22
BMS hs AC booster system.....	22
BMS hp MG booster system 6"	23
BMS hp MG booster system 8"	23
BMS hp MGE booster system 6"	24
BMS hp MGE booster system 8"	24
10. Performance curves	25
BMS hs PM, 17-22.....	25
BMS hs PM, 30-26.....	26
BMS hs PM, 46-17.....	27
BMS hs PM, 60-17.....	28
BMS hs AC, 17-22.....	29
BMS hs AC, 30-14.....	30
BMS hs AC, 30-26.....	31
BMS hs AC, 46-17.....	32

BMS hs AC, 60-17	33
BMS hp, 17-3, 17-5 and 17-7	34
BMS hp, 30-3, 30-5 and 30-7	35
BMS hp, 46-2, 46-4 and 46-6A	36
BMS hp, 60-2, 60-4 and 60-6	37
BMS hp, 77-2A and 77-3	38
BMS hp, 95-2 and 95-3	39
BMS hp, 125-1 and 125-2AA	40
BMS hp, 160-1A, 160-1 and 160-2AA	41
BMS hp, 215-1A and 215-1	42
11. Dimensions and weight	43
BMS hs PM booster system	43
Frequency converter for PM motor	44
Service connector	44
BMS hs AC booster system	45
BMS hp MG booster system 6"	46
BMS hp MG booster system 8"	47
BMS hp MGE booster system 6"	48
BMS hp MGE booster system 8"	49
12. Technical data	50
Material specification for BMS hs and BMS hp pump	50
Material specification for thrust-bearing housing	51
13. Accessories	52
CUE frequency converter	52
BMS hp	55
Customised BMS pumps	55
14. Grundfos Product Center	56

1. Product introduction

Reducing CO₂ emissions is one of the greatest challenges in connection with saving the environment. That is one of the reasons why Grundfos has developed the new booster systems, Grundfos BMS hs (high speed) and BMS hp (high-pressure inlet).

Grundfos BMS hs

BMS hs is a range of booster systems for reverse osmosis and filtration applications. These booster systems offer higher efficiency than the previous ranges. The reason is a direct-coupled pump which is powered by a permanent-magnet high speed motor (PM) or an asynchronous high-speed motor (AC). The permanent-magnet motor is supplied with a special designed Emerson drive. The permanent-magnet solution is only suitable for 400 V. The asynchronous motor has to be controlled by a variable-frequency drive, to reach the high speed. The variable-frequency drive must fit motor voltages of 400 V and the mains supply at the installation site. Together with an improved design, this makes both maintenance and service easier than ever, and you have a winning concept.

The BMS hs pump is delivered with a built-in non return valve.

If you use an asynchronous motor in countries that use 460 V, make sure that the variable-frequency drive can convert from 460 V to 400 V.

Caution



TM05 9569 4113 - TM05 9570 4113

Fig. 1 BMS hs booster system

Grundfos BMS hp

BMS hp is especially used when a high inlet pressure is needed. BMS hp is a range of booster systems for reverse osmosis and filtration applications, offering higher efficiency than previous ranges.



TM06 1045 5115

Fig. 2 BMS hp booster system

EuP ready

The BMS hp pumps are energy-optimised and comply with the EuP Directive (Commission Regulation (EC) No 547/2012) which became effective on 1 January 2013. As from this date, all pumps are classified and graduated in a new energy efficiency index (MEI).



Minimum Efficiency Index (MEI) is the dimensionless scale unit for hydraulic pump efficiency at best efficiency point, part load and overload.

EU regulations set efficiency requirements to MEI ≥ 0.1 as from 1 January 2013 and MEI ≥ 0.4 as from 1 January 2015. An indicative benchmark for the best-performing water pumps available on the market in 2012 is MEI ≥ 0.70.

Efficiency and MEI index

Pump type	Efficiency [%]	MEI
BMS hp 17-9	74	≥ 0.76
BMS hp 30-9	75	≥ 0.50
BMS hp 46-9	76	≥ 0.50
BMS hp 60-9	77	≥ 0.60
BMS hp 77-9	78	≥ 0.44
BMS hp 95-9	79	≥ 0.50
BMS hp 125-9	79	≥ 0.37
BMS hp 160-9	80	≥ 0.39
BMS hp 215-9	83	≥ 0.46

For more information about the new energy directive and MEI index please visit:

- energy.grundfos.com
- europump.eu/efficiencycharts

2. Performance range

BMS hs PM booster system

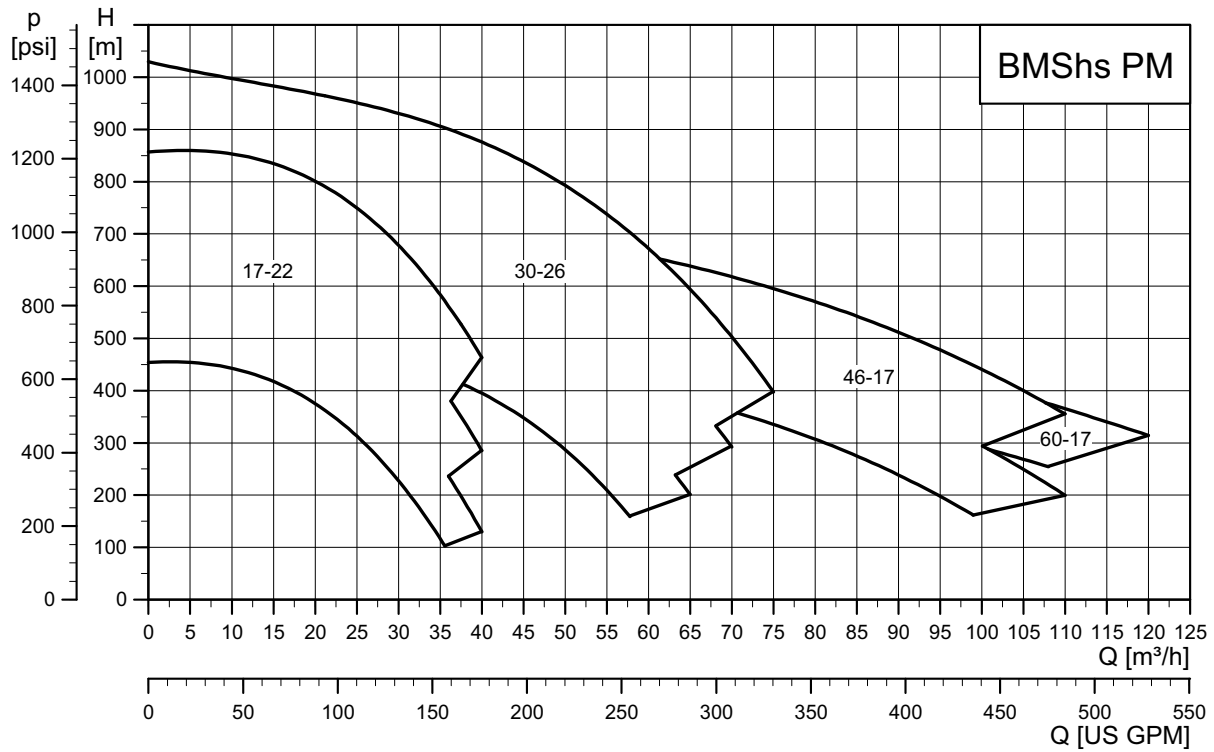

TM05 9198 1215

Fig. 3 Performance range, BMS hs, PM

BMS hs AC booster system

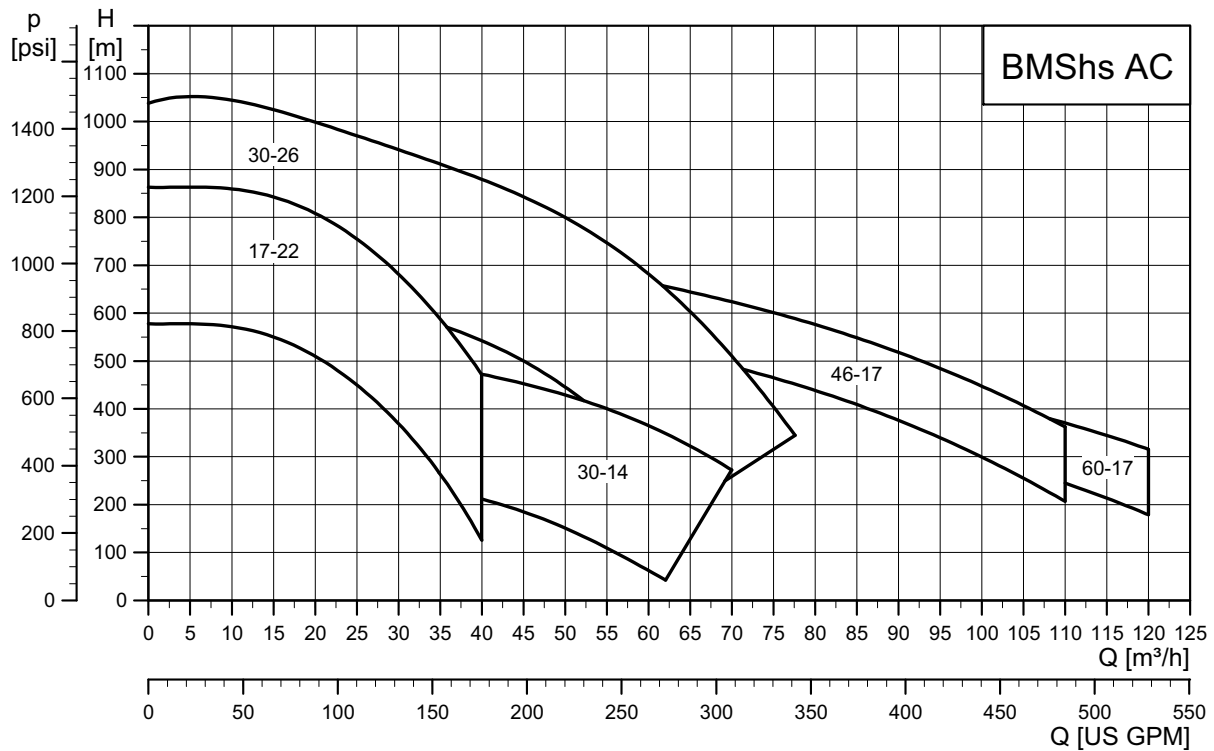

TM06 5614 1215

Fig. 4 Performance range, BMS hs AC

Performance range

BMS hp MG/MGE booster system

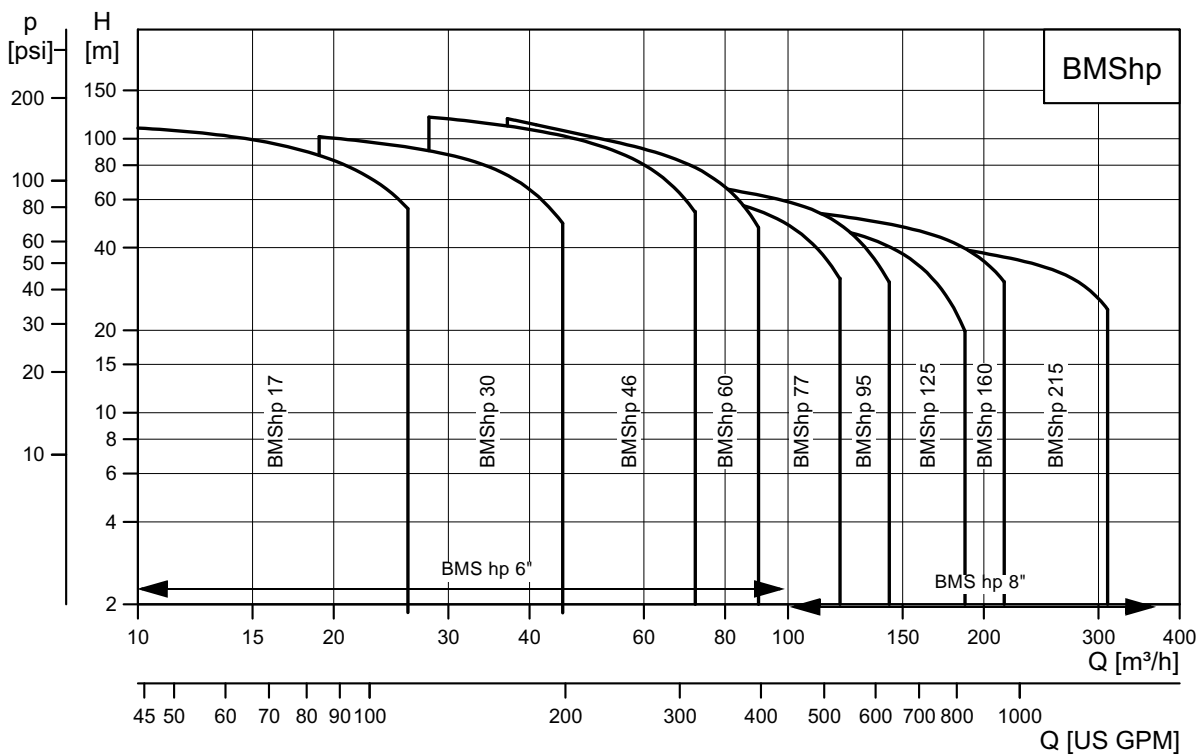

TM06 0729 4314

Fig. 5 Performance range, BMS hp MG/MGE, 60 Hz

3. General description, BMS hs and BMS hp

The sections below describe the common details for BMS hs and BMS hp.

Type key

Example	BMS 30 -26 hs -E -C -P -A
Pump	
BMS	
BMSX	Includes pressure exchanger and BM hp pump
BMST	Includes BMT pump
Rated flow rate [m³/h]	
Number of stages	
Type	
hs	High-pressure pump with high speed
hp	Pump with high pressure inlet
Motor*	
A	MG
B	MMG
C	MGE
D	MMGE
E	PM
X	No motor
Materials	Pump 1.4539/904L
Code for rubber parts	
P	NBR
V	FKM
Shaft seal	
A	Silicon carbide and carbon

Note: * Grundfos motors
 Grundfos MG and MMG:
 • With external frequency converter.
 Grundfos PM (permanent-magnet motor):
 • With external frequency converter.
 Grundfos MGE and MMGE:
 • With integrated frequency converter.

Pumped liquids

Thin, non-explosive liquids, not containing solid particles or fibres. The liquid must not chemically attack the pump materials. In case of doubt, contact Grundfos.

The pumps must never operate with liquid containing substances that would remove the surface tension, e.g. soap. If you use this type of detergent to clean the system, lead the liquid around the pumps via a bypass.

If the density and/or viscosity of the pumped liquid is higher than that of water, it may be necessary to use motors with a higher output than the standard output stated.

BMS hs booster systems are designed for brackish water and seawater.

Maximum liquid temperature

40 °C (104 °F).

Contact Grundfos in case of higher temperatures.

Curve conditions

The guidelines below apply to the curves on the following pages.

- All curves are based on average values according to ISO 9906: 2012 3B.
- If a minimum performance is required, carry out individual measurements.
- The curves apply to a kinematic viscosity of 1 mm²/s (1 cSt).
- The power curve P2 (hp) shows pump input power per stage.
- The efficiency curve η shows pump efficiency, including BMS hs pump, motor and frequency converter.
- The performance tests have been made at a water temperature of 20 °C (68 °F).
- Test liquid: airless water.

The conversion between head H (m) and pressure p (kPa) has been made for water with a density of ρ = 1000 kg/m³ (62.4 lb/ft³). If the density differs from this value, the created pressure will be proportional to the density.

Note *BMS hs AC curves shown with slip compensation.*

Parallel operation

If a flow rate higher than that of a single module is required, several modules are connected in parallel. Find the resulting flow rate by adding the flow rate of each individual module. The pressure will be the same as for one pump.

Flushing

When the booster system is used in a reverse osmosis system or similar applications pumping seawater or aggressive water, install a flush pump to avoid corrosion. Flush the system with clean fresh water until the salinity is lower than 1000 ppm TDS in the entire system.

Filtration

BMS hs, BMS hp, BMST: Filter the raw water to maximum 30 microns.

BMSX: Filter the raw water to maximum 10 microns.

Pump type	Filter [micron absolute]
BMS hs	
BMS hp	30
BMST	
Pressure exchanger	10

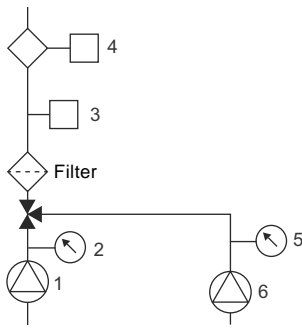

Fig. 6 Filtration

Pos.	Description
1	Raw-water feed pump
2	Pressure gauge (raw-water)
3	Low-pressure switch
4	Flowmeter
5	Pressure gauge (fresh-water pump)
6	Fresh-water flush pump

TM05 8862 2813

Automatic control devices

To protect the pumps against dry running, fit the system with flow and pressure control devices.

A pressure switch on the inlet side is sized in accordance with the estimated inlet pressure. At a pressure lower than 1 bar (14.5 psi), an alarm is given and the pump will stop.

We recommend that you fit all outlet connections of the system with flow switches that will stop the system at the set minimum flow rate.

The control devices ensure a correct inlet pressure.

Flow switch cutting-in is adjusted for a minimum time delay corresponding to the maximum starting frequency of the system.

Automatic safety devices

The safety devices below must be built into the system to protect the pump. See fig. 7.

- Flow switch and/or low-pressure switch to ensure a minimum flow of water and lubricate the thrust bearing and pump bearings.
- Flowmeter in each outlet pipe.
- Low-pressure switch on the booster system inlet sized in accordance with the estimated inlet pressure. At a pressure lower than 1 bar (14.5 psi), an alarm is given, and the pump will stop.
- High-pressure switch on the outlet pipe. The high-pressure switch will stop the pump at a set maximum pressure.

The above safety devices ensure a correct inlet pressure and a minimum flow for lubrication.

A minimum time delay equivalent to the maximum starting frequency of the system has been set for flow switch cutting-in.

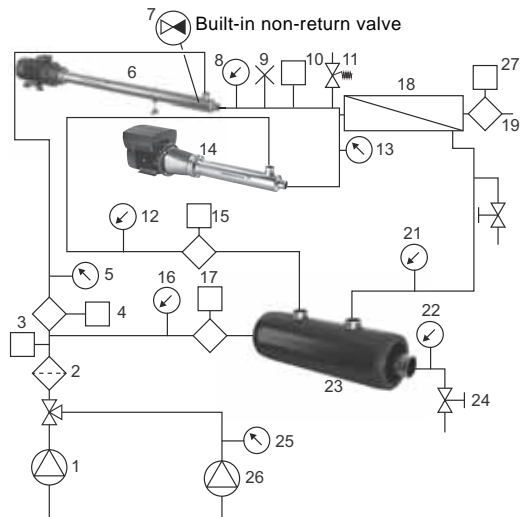

Fig. 7 Example of BMSX booster system

Pos.	Description
1	Raw-water feed pump
2	Filter
3	Low-pressure switch
4	Flowmeter
5	Pressure gauge (raw water)
6	BMS hs pump with built-in non-return valve
7	Non-return valve (built into BMS hs)
8	Pressure gauge (BMS hs outlet pressure)
9	Air vent
10	High-pressure switch
11	Pressure relief valve
12	Pressure gauge (BMS hp inlet pressure)
13	Pressure gauge (BMS hp outlet pressure)
14	BMS hp pump
15	Flowmeter (high-pressure raw water)
16	Pressure gauge (low-pressure raw water)
17	Flowmeter (low-pressure raw water)
18	Membrane filter
19	Permeate
20	Cleaning flush valve
21	Pressure gauge (high-pressure concentrate)
22	Pressure gauge (low-pressure concentrate)
23	Pressure exchanger
24	Concentrate valve
25	Pressure gauge (fresh-water)
26	Fresh-water flush pump
27	Flowmeter for permeate

TM05 9617 4213

4. Grundfos BMS hs



TM05 9569 4113

Fig. 8 BMS hs pump

Applications

The BMS hs booster system is suitable for the following applications:

- water treatment plants
 - reverse osmosis in domestic water supply systems
 - hospitals, laboratories as well as chemical, electronics and metal industries
 - ultra-filtration in chemical and galvanic industries
 - painting workshops, metal and mineral industries
- pressure boosting
- liquid transfer.

Reverse osmosis systems

Grundfos offers three different booster systems for reverse osmosis:

- Grundfos BMS hs
- Grundfos BMST
- Grundfos BMSX.

Standard pumps

BMS hs booster system

The following standard pumps are used for the BMS hs booster system:

- SP 17-22
- SP 30-14
- SP 30-26
- SP 46-17
- SP 60-17.

Note: The pumps are supplied with non-return valves.

Operating limits

We recommend that you always keep the capacity of the booster systems within the recommended flow rate and pressure range of each individual pump.

BMS hs booster system

Recommended flow rate at 25 °C (77 °F)						
Type	[m ³ /h]		US [gpm]			
BMS hs 17-22	4-40		17.6 - 176			
BMS hs 30-14	7-70		31-308			
BMS hs 30-26	7.5 - 75		33-330			
BMS hs 46-17	11-110		48.2 - 482			
BMS hs 60-17	12-120		53-530			

Recommended pressure						
Type	Inlet pressure				Outlet pressure	
	Min. [bar]	Min. [psi]	Max. [bar]	Max. [psi]	Max. [bar]	Max. [psi]
BMS hs 17-22						
BMS hs 30-14						
BMS hs 30-26	1	14.5	35	507.6	82.7	1200
BMS hs 46-17						
BMS hs 60-17						

Note: If there is a risk of exceeding the maximum inlet or outlet pressure, we recommend that you install a safety valve.

Note: Maximal permissible liquid temperature is 40 °C (104 °F). If you have an application for higher temperature, contact Grundfos.

Operating conditions

Sound pressure level

The sound pressure level of pumps with a 4500 rpm motor is lower than 80 dB(A).

The sound pressure level of pumps with a 5000 or 5500 rpm motor is lower than 85 dB(A).

Construction

Modified standard submersible pumps are used for the BMS hs booster systems. The pumps are centred in the stainless-steel (Duplex) sleeve.

BMS hs pumps are supplied with a high speed motor which need to be controlled by a frequency converter.

Inlet and outlet: 3" Victaulic couplings.

Motor types

Permanent-magnet high speed motor (PM)

The BMS hs PM booster system is supplied with a high-class synchronous permanent-magnet motor and a lightweight product. The weight is approx. 1/4 and the size 1/3 of a standard asynchronous motor.



Copyright Leroy-Somer 2013

TM05 9589 4113

Fig. 9 Example of a permanent-magnet motor

The permanent-magnet motor is controlled by a frequency converter (POWERDRIVE MD or FX) and as standard protected by PTC sensors.

Enclosure class: IP55.

Power P2: 44-180 kW (59-241 HP).

Optional: PT100.

Optional: space heater/anti-condensation heater.

Rated speed

Normal operation: 4000-5500 min⁻¹.

Flush operation: down to 1700 min⁻¹.

The motor is controlled by factory-set ramp times.

Asynchronous high speed motor (AC)

The BMS hs AC booster system is supplied with an asynchronous high speed motor. The motor is smaller and lighter than a standard asynchronous motor.

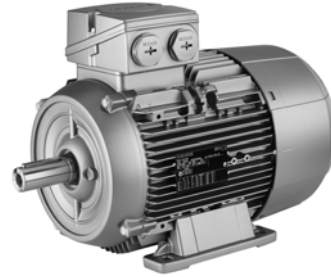

Copyright

Publication and reproduction rights are reserved by Siemens AG. Image source "© Siemens AG 2015, All rights reserved".

TM06 6081 0616

Fig. 10 Example of AC motor

The asynchronous high speed motor is controlled by a frequency converter and as standard protected by PT100 sensors.

Enclosure class: IP54.

Power P2: 44-180 kW (59-241 HP).

Certificate: cURus approval.

Optional: space heater/anti-condensation heater.

Other options on request

Rated speed

Normal operation: 4000-5500 min⁻¹.

Flush operation: down to 1700 min⁻¹.

The motor is controlled by ramp times.

Frequency converter for PM motor

Emerson POWERDRIVE MD and FX are user-friendly, UL-approved and compact frequency converters.



GR-1015353

Fig. 11 Example of POWERDRIVE MD2

Providing high-performance control of induction or synchronous permanent-magnet motors, the frequency converters are ideal for any industrial or tertiary variable-speed application up to 5500 min⁻¹.

Temperature

Storage and transport temperature: -15 to 60 °C (-59 to 140 °F).

Operating temperature: -10 to 40 °C (-50 to 104 °F), up to 50 °C (122 °F) with derating.

Humidity

Relative humidity in accordance with IEC 60068-2-56: lower than 90 % non-condensing.

Altitude

0 to 4000 m, with derating of operating temperature of 0.6 °C (33 °F) per 100 m between 1000 and 4000 m.

Voltage

FX: 400 V - 10 %/+ 6 %.

MD2MS: 400 V - 10 %/+ 5 %.

Frequency

FX: 50-60 Hz ± 2 %.

MD2MS: 50-60 Hz ± 5 %.

Enclosure class

FX: IP54.

MD2MS: IP21 or optional IP54.

Factory-set ramp times for PM motor

The ramp-up and ramp-down times ensure safe operation during startup, normal operation and shutdown. See fig. 12.

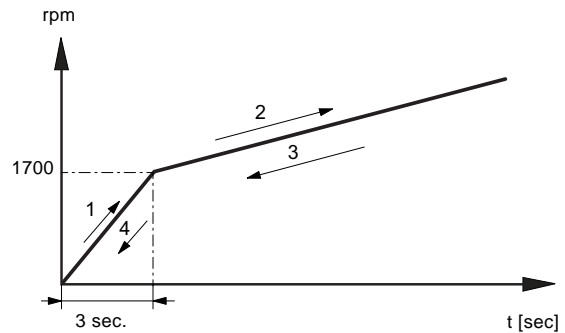

TM05 8860 2813

Fig. 12 Ramp times

1. Ramp up: From 0 to 1700 rpm, maximum 3 seconds.
2. Ramp up: From 1700 rpm to maximum speed, 1500 rpm/min
3. Ramp down: From maximum speed to 1700 rpm, 1500 rpm/min
4. Ramp down: From 1700 to 0 rpm, maximum 3 seconds.

Benefits

- Quick replacement of modules on site. You can change the power module in less than 1 hour.
- Each module is easy to access independently.
- The heaviest module weighs less than 20 kg.
- Reduced staff and equipment costs.

Modularity

POWERDRIVE MD incorporates the following:

- inverter
- rectifier
- cooling module
- electronic control boards.

POWERDRIVE MD cabinet

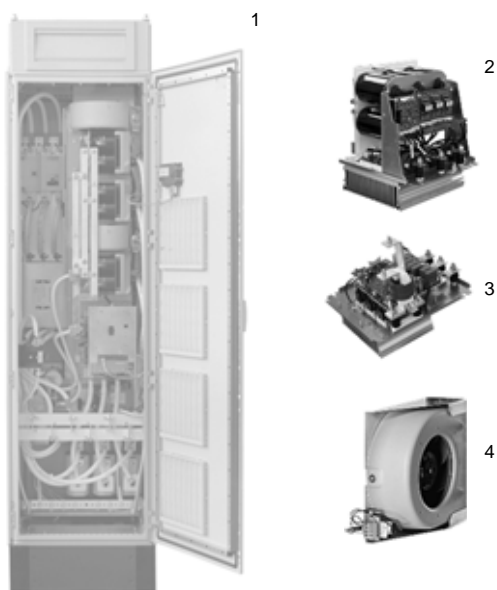

Copyright Leroy-Somer 2013

Fig. 13 Example of POWERDRIVE MD module

Pos.	Description
1	POWERDRIVE MD cabinet
2	Inverter module
3	Rectifier module
4	Cooling fan

TM05 9594 4113 - TM05 9591 4113 - TM05 9592 4113 - TM05 9593 4113

Add-on modules

- Fieldbus module
- IO module.

These modules are assembled on a frame or in a standard cabinet.

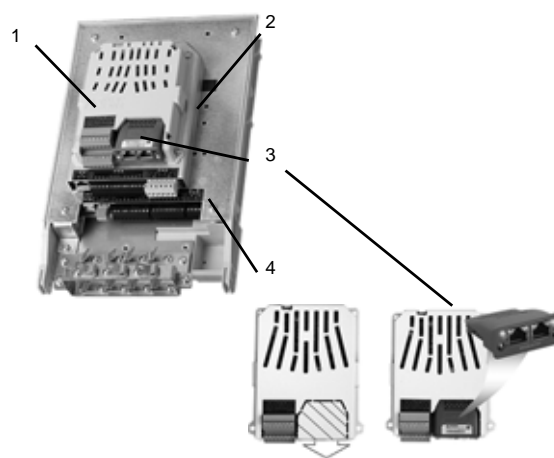

Copyright Leroy-Somer 2013

Fig. 14 Example of assembled module

Pos.	Description
1	Fieldbus module
2	IO module
3	CM fieldbus module
4	Control board

TM05 9609 4113 - TM05 9608 4113

High-performance control

POWERDRIVE MD and FX control induction motors according to different modes (fixed U/F ratio or U/F ratio with dynamic energy optimization, flux vector control, etc.). Thanks to a virtual sensor function (sensor-less), POWERDRIVE MD and FX also control machines with magnets with no additional sensors, thus offering substantial savings in terms of wiring and installation. The speed/position-feedback option is ideal for applications where torque control is essential at zero speed and applications requiring very high dynamic performance.

User interface

The setup is very simple, using the colour touch screen on the front panel.



Copyright Leroy-Somer 2013

Fig. 15 User interface

The user interface is easy to use and provides instant, intuitive access to parameters and operating data.

The status display which provides information on the drive status (stopped or running), trip history and backup is just one of the functions offered by this user-friendly user interface.

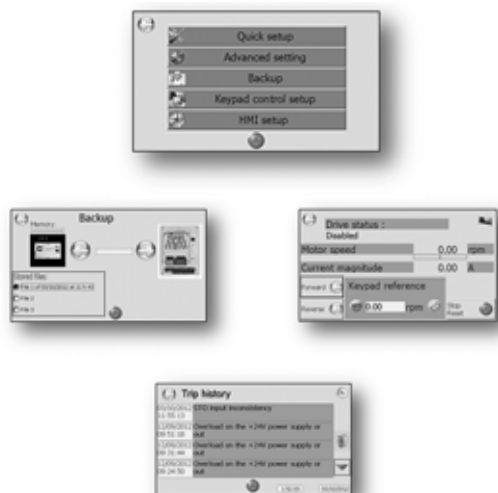

Copyright Leroy-Somer 2013

Fig. 16 Example of user interface

Quick setup

When using the Quick setup menu, five interactive menus are available:

- basic control (Ctr)
- motor nameplate (Mtr)
- speeds and ramps (Spd)
- customer's interface (I/O)
- application parameters (Apl).

Advanced setup

When using the advanced setup menu, you have access to all POWERDRIVE MD or FX menus.

Backup

The backup function allows you to save up to three complete set of drive parameters without any additional storage media.

Display

Operating conditions, modes and parameters are available to the operator.

Diagnostics

To ensure reliable operation, a preventive self-test is performed at each startup.

Furthermore, POWERDRIVE MD and FX incorporate time-stamping of the latest ten trips and tracking of the electrical, mechanical and thermal physical values preceding the latest trip over a period of time:

- fault history of latest 10 trips
- timestamp
- operating conditions prior to latest trip memorised
- troubleshooting help.

Commissioning software

Use the advanced parameter-setting software MDX-SOFT to start up your system. MDX-SOFT offers PC-guided setup and a good overview.

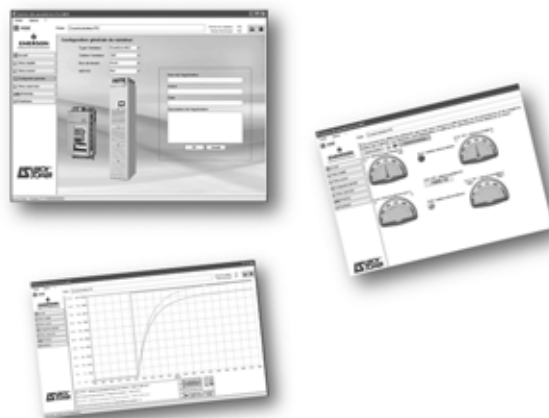

Copyright Leroy-Somer 2013

Fig. 17 Commissioning software

Features

- Parameter setting
- file export and comparison
- 4-channel scope function
- backup.

TM05 9600 4113

TM05 9604 4113 - TM05 9601 4113 - TM05 9602 4113 - TM05 9603 4113

TM05 9607 4113 - TM05 9605 4113 - TM05 9606 4113

Safety

POWERDRIVE MD and FX have a built-in safety function (Safe Torque Off) in accordance with the requirements of ISO 13849 and EN 62061.

Communication

You can use the add-on fieldbus modules to adapt the drive to control/monitoring systems:

- MDX-Modbus
- MDX-PROFIBUS
- MDX-PROFINET
- MDX-Canopen.

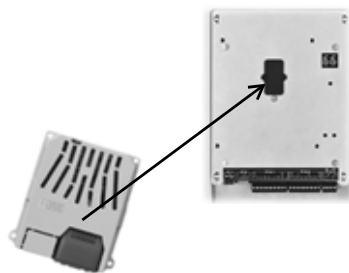

Copyright Leroy-Somer 2013

Fig. 18 Example of CM fieldbus module

TM05 9599 4113 - TM05 9597 4113

Energy savings

POWERDRIVE MD and FX reduce energy costs while improving processes and productivity. The POWERDRIVE MD or FX and permanent-magnet motor solution creates the most powerful drive available on any market where energy efficiency is a priority.

5. Grundfos BMS hp



TM06 1045 4113

Fig. 19 BMS hp pump

Applications

The Grundfos BMS hp booster system is suitable for industrial and water supply applications where the inlet pressure is high, up to 82.7 bar (1200 psi). The BMS hp booster systems are used to increase the system pressure up to 82.7 bar (1200 psi).

The BMS hp booster system is the optimum solution for applications requiring the following:

- pumps capable of coping with high system pressures
- a minimum of maintenance.

Typical applications

BMS hp booster systems are suitable for the following typical applications:

- Water treatment where energy recovery devices (ERD), like pressure exchangers are used, such as:
 - reverse osmosis in domestic water supply systems
 - hospitals, laboratories as well as chemical, electronics and metal industries
 - ultra-filtration in chemical and galvanic industries
 - painting workshops, metal and mineral industries.
- Liquid transfer.
- Pressure boosting.
- Closed circulation systems with a high static pressure.

Standard pumps

The following standard pumps are available for the BMS hp booster systems:

- SP 17-3, 17-5 and 17-7
- SP 30-3, 30-5 and 30-7
- SP 46-2, 46-4 and 46-6A
- SP 60-2, 60-4 and 60-6
- SP 77-2 and 77-3
- SP 95-2 and 95-3
- SP 125-1 and 125-2
- SP 160-1 and 160-2
- SP 215-1.

SP standard pumps are with a 6" sleeve in range 17-60 and 8" sleeve in range 77-215.

Note: The BMS hp booster systems come without non-return valves.

Operating limits

We recommend that you always keep the capacity of the booster systems within the recommended flow rate and pressure range of each individual pump.

BMS hp

Recommended flow rate at 25 °C (77 °F)		
Type	[m ³ /h]	US [gpm]
BMS hp 17-3, 17-5 and 17-7	10-26	44 - 114.5
BMS hp 30-3, 30-5 and 30-7	19-45	83.7 - 198
BMS hp 46-2, 46-4 and 46-6A	28-72	123-317
BMS hp 60-2, 60-4 and 60-6	37-90	163 - 396.3
BMS hp 77-2 and 77-3	47-120	207-528
BMS hp 95-3	57-143	251-629
BMS hp 125-2	75-187	330-823
BMS hp 160-2	90-215	396-946
BMS hp 215-1	115-310	506-1364

Recommended pressure						
Type	Inlet pressure				Outlet pressure	
	Min. [bar]	Min. [psi]	Max. [bar]	Max. [psi]	Max. [bar]	Max. [psi]
BMS hp 17-3, 17-5 and 17-7	1	14.5	80	1160	82.7	1200
BMS hp 30-3, 30-5 and 30-7	1	14.5	80	1160	82.7	1200
BMS hp 46-2, 46-4 and 46-6A	1	14.5	80	1160	82.7	1200
BMS hp 60-2, 60-4 and 60-6	1	14.5	80	1160	82.7	1200
BMS hp 77-3	1	14.5	80	1160	82.7	1200
BMS hp 95-3	1	14.5	80	1160	82.7	1200
BMS hp 125-2	1	14.5	80	1160	82.7	1200
BMS hp 160-2AA	1	14.5	80	1160	82.7	1200
BMS hp 215-1	1	14.5	80	1160	82.7	1200

Note: If there is a risk of exceeding the maximum inlet or outlet pressure, we recommend that you install a safety valve.

Note: Maximal permissible liquid temperature is 40 °C (104 °F). If you have an application for higher temperature, contact Grundfos.

Construction

Modified standard submersible pumps are used for the BMS hp booster systems. The pumps are centred in the stainless-steel (Duplex) sleeve.

Inlet and outlet:

- BMS hp 6": 3" Victaulic couplings
- BMS hp 8": 6" Victaulic couplings.

Motor

Asynchronous motor with integrated variable-frequency drive (Grundfos standard MG, MGE and Siemens motors).

Motor type

You can fit BMS hp with a totally enclosed, fan-cooled, 2-pole Grundfos standard MG or MGE motor. The motor has principal dimensions according to EN standards and electrical tolerances according to EN 60034.

3 to 22 kW (4 to 30 hp): E-pumps with three-phase MGE motors.

Grundfos MGE 100, MGE 132, MGE 160 and MGE 180 motors offer these features:

- Three-phase mains connection.
- Three-phase, asynchronous squirrel-cage induction motors designed to IEC, DIN and VDE guidelines and standards. The motors incorporate a frequency converter and PI controller.
- Used for continuously variable-speed control of Grundfos E-pumps.

Motors without integrated variable-frequency drive require an external variable-frequency drive to obtain duty points as shown on performance curves

Note

Voltages

- 3 x 380-480 V.

Enclosure class

- IP55 (IEC 34-5).

Required ramp times

The ramp-up and ramp-down times ensure safe operation during startup, normal operation and shutdown.

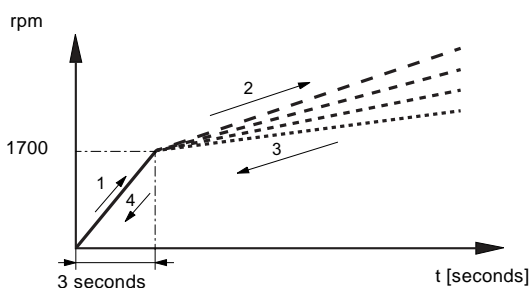

TM06 1079 1614

Fig. 20 Ramp up, BMS hp

1. Ramp up: From 0 to 1700 rpm, maximum 3 seconds.
2. Ramp up: From 1700 rpm to maximum speed, 1500 rpm/min
3. Ramp down: From maximum speed to 1700 rpm, 1500 rpm/min
4. Ramp down: From 1700 to 0 rpm, maximum 3 seconds.

Operating conditions

Sound pressure level

The sound pressure level of BMS hp 6" booster systems is below 72 dB(A) and the sound pressure level of BMS hp 8" booster systems is below 80 dB(A).

Temperature

Storage and transport temperature: -40 to 60 °C (-104 to 140 °F).

Operating temperature: -20 to 40 °C (-68 to 104 °F), up to 50 °C (122 °F).

Humidity

Relative humidity in accordance with IEC 60068-2-56: lower than 90 % non-condensing.

Altitude

0 to 4000 m, with derating of operating temperature of 0.6 °C per 100 m between 1000 and 4000 m.

Rated speed

60 Hz: 3500 min⁻¹.

6. High pressure booster systems

The following subsections describe systems which are typically used for high-pressure booster applications.

BMS hs booster system

You can use the BMS hs booster system in several different fresh-water applications.

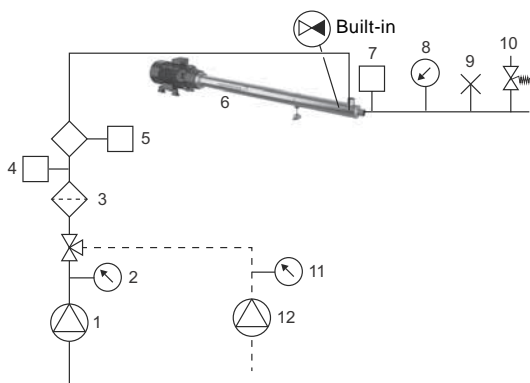

Fig. 21 Example of BMS hs booster system

Pos.	Description
1	Raw-water feed pump
2	Pressure gauge (raw water)
3	Filter
4	Low-pressure switch
5	Flowmeter
6	BMS hs pump with built-in non-return valve.
7	High-pressure switch
8	Pressure gauge (BMS hs outlet pressure)
9	Air vent
10	Pressure relief valve
11	Pressure gauge (fresh-water pump)
12	Fresh-water flush pump*

* A fresh-water flush pump must be installed in applications for seawater desalination or similar applications.

The function of a BMS hs booster system

The BMS hs pump creates the needed flow rate and pressure in the system. The frequency converter ensures low operating costs and safe ramp-up and ramp-down. The factory-set ramp times prevent damage due to water hammer.

BMS hp booster system

You can use the BMS hp booster system in several different high pressure applications. Especially when you need a high inlet pressure.

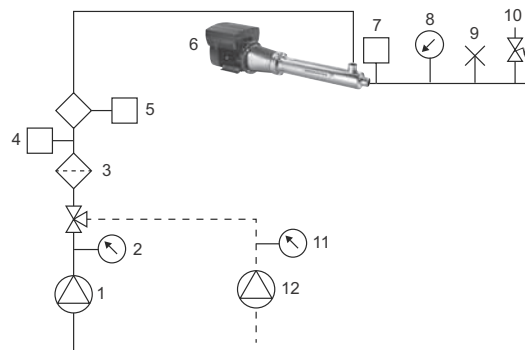

Fig. 22 Example of BMS hp booster system

Pos.	Description
1	Raw-water feed pump
2	Pressure gauge (raw water)
3	Filter
4	Low-pressure switch
5	Flowmeter
6	BMS hp pump
7	High-pressure switch
8	Pressure gauge (BMS hp outlet pressure)
9	Air vent
10	Pressure relief valve
11	Pressure gauge (fresh-water pump)
12	Fresh-water flush pump*

* A fresh-water flush pump must be installed in applications for seawater desalination or similar applications.

The function of a BMS hp booster system

The BMS hp pump creates the needed flow rate and pressure in the system. The frequency converter ensures low operating costs and safe ramp-up and ramp-down. The factory-set ramp times prevent damage due to water hammer.

TM06 1077 1514

7. Reverse osmosis systems

The following subsections describe three systems typically used for the reverse osmosis process.

BMS hs system

You can use the BMS hs booster system in reverse osmosis systems.

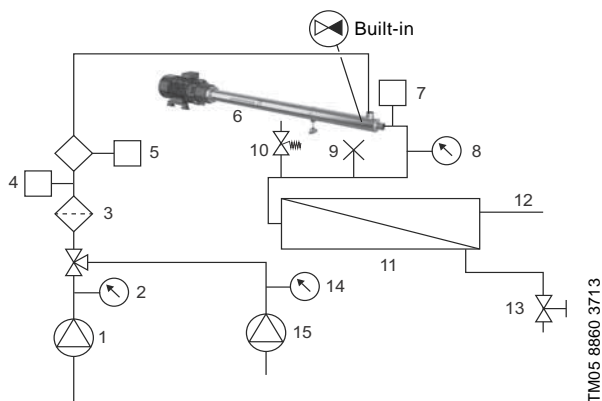

TM05 8860 3713

Fig. 23 Example of BMS hs booster system

Pos.	Description
1	Raw-water feed pump
2	Pressure gauge (raw water)
3	Filter
4	Low-pressure switch
5	Flowmeter
6	BMS hs pump with built-in non-return valve
7	High-pressure switch
8	Pressure gauge (BMS hs outlet pressure)
9	Air vent
10	Pressure relief valve
11	Membrane filter
12	Permeate
13	Pressure control valve
14	Pressure gauge (fresh-water)
15	Fresh-water flush pump

How does it work?

The BMS hs pump creates the needed flow rate and pressure through the membranes of the system. The frequency converter ensures low operating costs and safe ramp-up and ramp-down. The factory-set ramp times prevent damage due to water hammer.

BMST system

A BMST booster system consists of a BMS hs pump and a BMT pump.

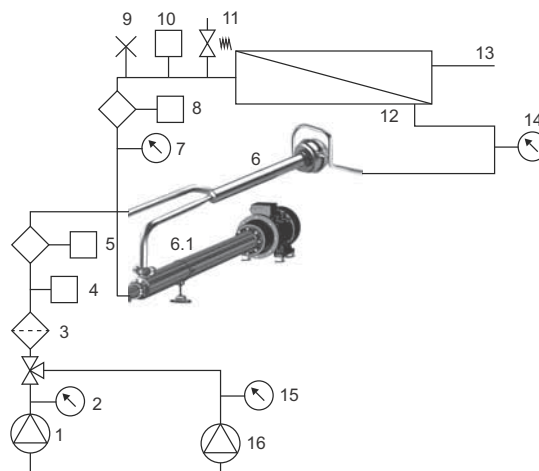

TM05 8861 3713

Fig. 24 Example of BMST booster system

Pos.	Description
1	Raw-water feed pump
2	Pressure gauge (raw water)
3	Filter
4	Low-pressure switch
5	Flowmeter
6	BMT pump
6.1	BMS hs pump
7	Pressure gauge (BMST outlet pressure)
8	Flowmeter
9	Air vent
10	High-pressure switch
11	Pressure relief valve
12	Membrane filter
13	Permeate
14	Pressure gauge (high-pressure concentrate)
15	Pressure gauge (fresh-water)
16	Fresh-water flush pump

A BMST system makes it possible to deliver the same performance as with a standard centrifugal pump, but saves up to 35 % of the total power consumption.

How does it work

The BMS hs pump creates the needed flow rate and pressure through the membranes of the system. 65 % of the energy needed are generated by the BMS hs pump, and the remaining 35 % are provided by the Pelton turbine. The turbine is driven by the high-pressure concentrate outlet. The BM pump driven by the Pelton turbine increases the inlet pressure of the BMS hs pump.

This makes it possible to save up to 35 % of the total power consumption.

BMSX system

A BMSX booster system consists of a BMS hs pump (high speed) pump, a BMS hp pump (high inlet pressure) pump and an isobaric pressure exchanger.

High efficiency

The BMSX system has a unique design dedicated to desalination of seawater and brackish water. The isobaric pressure exchanger has an efficiency of up to 98 %, thus ensuring high energy recovery and low operating costs.

How does it work

The BMS hs pump creates the needed flow rate and pressure through the membranes of the system. However, only 40 % of the energy needed are generated by the BMS hs pump. The remaining 60 % are provided by the pressure exchanger. The pressure exchanger transfers energy from the high-pressure concentrate outlet to the raw-water inlet, thus increasing the raw-water pressure from 2 bar to the system pressure.

This is what makes it possible to reach the high efficiency of up to 97 % for the pressure exchanger. The pressure loss in the pressure exchanger is evened out by BMS hp and the frequency converter that maintain the desired pressure for the entire reverse osmosis process.

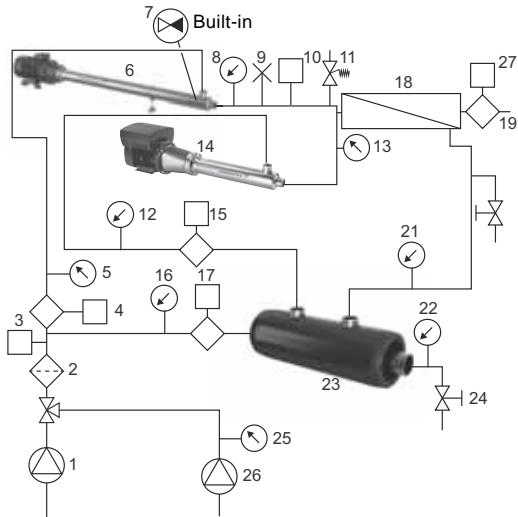

TM05 9617 4213

Fig. 25 Example of BMSX booster system

Pos.	Description
1	Raw-water feed pump
2	Filter
3	Low-pressure switch
4	Flowmeter
5	Pressure gauge (raw water)
6	BMS hs pump with built-in non-return valve
7	Non-return valve (built into BMS hs)
8	Pressure gauge (BMS hs outlet pressure)
9	Air vent
10	High-pressure switch
11	Pressure relief valve
12	Pressure gauge (BMS hp inlet pressure)
13	Pressure gauge (BMS hp outlet pressure)
14	BMS hp pump
15	Flowmeter (high-pressure raw water)
16	Pressure gauge (low-pressure raw water)
17	Flowmeter (low-pressure raw water)
18	Membrane filter
19	Permeate
20	Cleaning flush valve
21	Pressure gauge (high-pressure concentrate)
22	Pressure gauge (low-pressure concentrate)
23	Pressure exchanger
24	Concentrate valve
25	Pressure gauge (fresh-water)
26	Fresh-water flush pump
27	Flowmeter

8. Features and benefits

BMS hs booster system

The BMS hs booster system consists of a standard SP pump centred in a stainless-steel sleeve and a permanent-magnet high speed motor (PM) or a asynchronous high speed motor (AC). As the motor is directly coupled to the pump, it is easy to find a pump that suits your needs in Grundfos Product Center.

If the BMS hs booster system is to be used in a BMSX system, Grundfos has developed an easy-to-use selection tool. Fill in information about your needs, and the tool will tell you what to order.

BMS hs PM

Features:

- Motor controlled by variable-frequency drive.
- Built-in check valve.
- Speed range of 4000-5500 rpm.
- Set from factory.
- High-pressure booster up to 82.7 bar (1200 psi).
- Add-on module for external communication.
- Add-on module for input/output support - 6 digital and/or analog inputs/outputs.
- Remote control via the internet.

Benefits

- Built-in check valve
- easy-to-use selection tool
- log on anywhere via Internet connection
- plug and play, configured from factory
- small footprint
- low weight
- easy access to shaft seal and thrust bearing
- reduced maintenance
- only three tools for dismantling
- service connector
- automatic ramp-up/ramp-down
- variable-frequency drive self-test at startup
- built-in thrust bearing
- NBR pump bearings and seal rings
- ceramic/carbon thrust bearing
- silicon carbide/carbon shaft seal, especially designed for high pressure
- overload protection while running
- low downtime
- inlet and outlet pipes connected using Victaulic couplings, style 77DX
- high efficiency means energy savings
- easy maintenance and alignment
- extreme durability and reliability
- easy integration in any water treatment system
- designed for high flow rate and pressure.

BMS hs AC

Features:

- Motor controlled by variable-frequency drive.
- Built-in check valve.
- Speed range of 4000-5500 rpm.
- Set BMS hs AC according to the installation and operating instructions.
- High-pressure booster up to 82.7 bar (1200 psi).

Benefits

- Built-in non-return valve
- easy-to-use selection tool
- easy access to shaft seal and thrust bearing
- reduced maintenance
- only three tools for dismantling
- service connector
- automatic ramp-up/ramp-down
- built-in thrust bearing
- NBR pump bearings and seal rings
- ceramic/carbon thrust bearing
- silicon carbide/carbon shaft seal, especially designed for high pressure
- overload protection while running
- low downtime
- inlet and outlet pipes connected using Victaulic couplings, style 77DX
- easy maintenance and alignment
- extreme durability and reliability
- easy integration in any water treatment system
- designed for high flow rate and pressure.

BMS hp booster system

The BMS hp booster system consists of a standard SP pump with high inlet pressure and a MG, MGE or Siemens motor. If the BMS hp booster system is to be used in a BMSX system, Grundfos has developed an easy-to-use selection tool. Fill in information about your needs, and the tool will tell you what to order.

BMS hp MG

Features

- Motor controlled by variable-frequency drive
- speed range of 1700-3500 rpm
- reduced system wear
- high inlet-pressure up to 82.7 bar (1200 psi).

Benefits

- Perfect process control
- easy-to-use selection tool
- small footprint
- low weight
- extreme durability and reliability
- easy integration in any water treatment system
- designed for high flow rate and pressure
- built-in check valve as option
- inlet and outlet pipes connected using Victaulic couplings, style 77DX.

BMS hp MGE

Features

- Motor controlled by variable-frequency drive
- speed range of 1700-3500 rpm
- factory-set ramp times
- extra functions I/O functionality
- data collection
- reduced system wear
- high inlet-pressure up to 82.7 bar (1200 psi).

Benefits

- Perfect process control
- remote control, monitoring and data collection of the application and pump performance
- reduced installation and wiring costs
- easy-to-use selection tool
- small footprint
- low weight
- extreme durability and reliability
- easy integration in any water treatment system
- designed for high flow rate and pressure
- built-in check valve as option
- inlet and outlet pipes connected using Victaulic couplings, style 77DX.

9. Product range

BMS hs PM booster system and frequency converter

BMS hs booster	Power P2		Max. speed	Frequency converter	Efficiency	Product number
	[kW]	[hp]	[rpm]			
BMS 17-22 HS-E-C-P-A	70	94	5500	FX 75T	41	98467174
BMS 17-22 HS-E-C-P-A	70	94	5500	MD2MS 100T	63	98467175
BMS 17-22 HS-E-C-P-A	85	114	5500	MD2MS 120T	68	98467176
BMS 17-22 HS-E-C-P-A	85	114	5500	MD2MS 150T	58	98467177
BMS 17-22 HS-E-C-P-A	70	94	5000	FX 75T	66	98467178
BMS 17-22 HS-E-C-P-A	70	94	5000	MD2MS 100T	69	98467179
BMS 17-22 HS-E-C-P-A	44	59	4500	FX 60T	68	98467180
BMS 17-22 HS-E-C-P-A	52	70	4500	FX 75T	64	98467181
BMS 30-26 HS-E-C-P-A	140	188	5500	MD2MS 180T	67	98467182
BMS 30-26 HS-E-C-P-A	160	215	5500	MD2MS 220T	72	98467183
BMS 30-26 HS-E-C-P-A	140	188	5000	MD2MS 180T	72	98467184
BMS 30-26 HS-E-C-P-A	100	134	4500	MD2MS 120T	72	98467185
BMS 46-17 HS-E-C-P-A	180	241	5500	MD2MS 220T	72	98467186
BMS 46-17 HS-E-C-P-A	140	188	5000	MD2MS 180T	69	98467187
BMS 46-17 HS-E-C-P-A	160	215	5000	MD2MS 220T	71	98467188
BMS 60-17 HS-E-C-P-A	180	241	5000	MD2MS 220T	74	98467190

Accessories (frequency converter)

Add-on module	Part number
Base frame	98477866
MDX - PROFIBUS DP V1	98536322
MDX - PROFINET	98574712
MDX - Modbus	98574713
MDX - Canopen	98574714
LS MD2MS 100T RFI filter	98536323
LS MD2MS 120T/150T RFI filter	98536325
LS MD2MS 180T/220T RFI filter	98536326
LS MDX OI module (internet connection)	98536328
LS Colour tactile HMI with cable	98536330

BMS hs AC booster system

BMS hs booster	Power P2		Max. speed	Efficiency	Product number
	[kW]	[hp]	[rpm]		
BMS 17-22 HS-B-C-P-A	52	70	5000	68	99022832
BMS 17-22 HS-B-C-P-A	70	94	5500	68	99022843
BMS 17-22 HS-B-C-P-A	85	114	5500	68	99022844
BMS 30-14 HS-B-C-P-A	85	114	5500	70	99022845
BMS 30-26 HS-B-C-P-A	120	161	4500	71	99022846
BMS 30-26 HS-B-C-P-A	140	188	5500	72	99022847
BMS 30-26 HS-B-C-P-A	160	215	5500	70	99022848
BMS 46-17 HS-B-C-P-A	160	215	5500	68	99022849
BMS 46-17 HS-B-C-P-A	180	241	5500	69	99059893
BMS 60-17 HS-B-C-P-A	180	241	5000	70	99022850

BMS hp MG booster system 6"

Type	Motor output [P2]		Rated current I_N [A]	Efficiency total η [%]	Length [L]		Weight [kg]		Ship. vol. [m ³]	Product number R-version
	[kW]	[hp]			[mm]	[in]	Net	Gross		
BMS 17-3 HP	3	4.0	6.8 - 5.4	64	1281.0	50.4	96.1	186.1	0.962	98872087
BMS 17-5 HP	5.5	7.5	10.6 - 9.3	66	1458.0	57.4	96.1	186.1	0.155	98872088
BMS 17-7 HP	7.5	10.0	14.2 - 12.0	67	1567.0	61.7	135.2	225.2	0.155	98872090
BMS 30-3 HP	5.5	7.5	10.6 - 9.3	66	1432.0	56.4	119.9	209.9	0.152	98872101
BMS 30-5 HP	7.5	10.0	14.2 - 12.0	68	1624.0	63.9	136.1	226.1	0.160	98872102
BMS 30-7 HP	11	15.0	20.8 - 17.2	68	2018.0	79.4	189.3	279.3	0.270	98872103
BMS 46-2 HP	5.5	7.5	10.6 - 9.3	63	1382.0	54.4	118.5	208.5	0.148	98872104
BMS 46-4 HP	11	15.0	20.8 - 17.2	66	1798.0	70.8	183.4	273.4	0.243	98872105
BMS 46-6A HP	15	20.0	28.0 - 22.4	67	2024.0	79.7	202.7	292.7	0.271	98872106
BMS 60-2 HP	7.5	10.0	14.2 - 12.0	60	1370.0	53.9	128.7	218.7	0.137	98872107
BMS 60-4 HP	11	15.0	20.8 - 17.2	66	1798.0	70.8	183.3	273.3	0.243	98872109
BMS 60-6 HP	18.5	25.0	34.5 - 28.0	69	2068.0	81.4	215.9	305.9	0.277	98872110

On request, BMS hp MG is available for other voltages.

BMS hp MG booster system 8"

Type	Motor output [P2]		Rated current I_N [A]	Efficiency total η [%]	Length [L]		Weight [kg]		Ship. vol. [m ³]	Product number R-version
	[kW]	[hp]			[mm]	[in]	Net	Gross		
BMS 77-2A HP	11.0	15.0	20.8 - 17.2	64	1857.0	73.1	225.0	325.0	0.250	98872111
BMS 77-3 HP	18.5	25.0	34.5 - 28.0	70	2029.0	79.9	256.0	356.0	0.272	98872112
BMS 95-2 HP	15.0	20.0	28.0 - 22.4	69	1857.0	73.1	234.0	334.0	0.250	98872113
BMS 95-3 HP	22.0	30.0	40.0 - 32.5	71	2055.0	80.9	270.0	370.0	0.311	98872116
BMS 125-1 HP	18.5	25.0	34.5 - 28.0	68	1807.0	71.1	255.0	355.0	0.244	98872117
BMS 125-2AA HP	22.0	30.0	40.0 - 32.5	69	1988.0	78.3	281.0	381.0	0.302	98872119
BMS 160-1A HP	15.0	20.0	28.0 - 22.4	62	1763.0	69.4	208.0	308.0	0.239	98872120
BMS 160-1 HP	22.0	30.0	40.0 - 32.5	68	1833.0	72.2	271.0	371.0	0.280	98872121
BMS 160-2 HP	30.0	41.0	56.0 - 50.0	76	2022.0	79.6	300.0	390.0	0.514	98494526
BMS 215-1 HP	30.0	41.0	56.0 - 50.0	78	2005.0	78.9	300.0	390.0	0.510	98494527
BMS 215-1 HP	37.0	50.0	68.0 - 61.0	79	2030.0	79.9	346.0	436.0	0.516	98494528

On request, BMS hp MG is available for other voltages.

BMS hp MGE booster system 6"

Type	Motor output [P2]		Rated current I_N [A]	Efficiency total η [%]	Length [L]		Weight [kg]		Ship. vol. [m ³]	Product number R-version
	[kW]	[hp]			[mm]	[in]	Net	Gross		
BMS 17-3 hp	3	4	6.2 - 5.00	64	1281	50.4	101.4	191.4	0.399	98494496
BMS 17-5 hp	5.5	7.5	11.0 - 8.80	66	1458	57.4	103.0	192.8	0.399	98494497
BMS 17-7 hp	7.5	10	14.8 - 11.6	67	1567	61.7	145.6	235.6	0.234	98494498
BMS 30-3 hp	5.5	7.5	11.0 - 8.80	68	1432	56.4	126.6	216.6	0.399	98494499
BMS 30-5 hp	7.5	10.0	14.8 - 11.6	68	1624	63.9	146.5	236.6	0.399	98494500
BMS 30-7 hp	11.0	15	22.5 - 18.8	69	2018	79.4	219.9	309.8	0.441	98494511
BMS 46-2 hp	5.5	7.5	11.0 - 8.80	69	1382	54.4	125.0	215.0	0.399	98494512
BMS 46-4 hp	11.0	15	22.5 - 18.8	70	1798	70.8	213.8	303.8	0.399	98494513
BMS 46-6A hp	15	20	30.0 - 26.0	71	2024	79.7	235	325	0.442	98494514
BMS 60-2 hp	7.5	10	14.8 - 11.6	70	1370	53.9	139.0	229.1	0.399	98494515
BMS 60-4 hp	11.0	15.0	22.5 - 18.8	71	1798	70.8	213.7	303.7	0.399	98494516
BMS 60-6 hp	18.5	25.0	29.9 - 35.7	72	2068	81.4	248.3	338.3	0.500	98494517

On request, BMS hp MGE is available for other voltages.

BMS hp MGE booster system 8"

Type	Motor output [P2]		Rated current I_N [A]	Efficiency total η [%]	Length [L]		Weight [kg]		Ship. vol. [m ³]	Product number R-version
	[kW]	[hp]			[mm]	[in]	Net	Gross		
BMS 77-2 hp	11	15	22.5 - 18.8	70	1.822	71.7	153	243	0.388	98494518
BMS 77-3 hp	18.5	25	37-31	71	1.994	78.5	180	270	0.425	98494519
BMS 95-2 hp	15	20	30-26	72	1.822	71.7	167	257	0.388	98494520
BMS 95-3 hp	22	30	44-35	72	2.020	79.5	197	287	0.435	98494521
BMS 125-1 hp	18.5	25	37-31	74	1.771	69.7	180	270	0.378	98494522
BMS 125-2 hp	22	30	44-35	74	1.952	76.9	197	287	0.42	98494523
BMS 160-1 hp	15	20	30-26	74	1.727	67.9	167	257	0.368	98494524
BMS 160-1 hp	22	30	44-35	75	1.797	70.7	197	287	0.387	98494525

On request, BMS hp MGE is available for other voltages.

10. Performance curves

The power and efficiency curves for BMS hs with permanent-magnet motor displayed below include pump, motor and frequency converter (POWERDRIVE MD or FX). See section *Performance range* on page 5.

BMS hs PM, 17-22

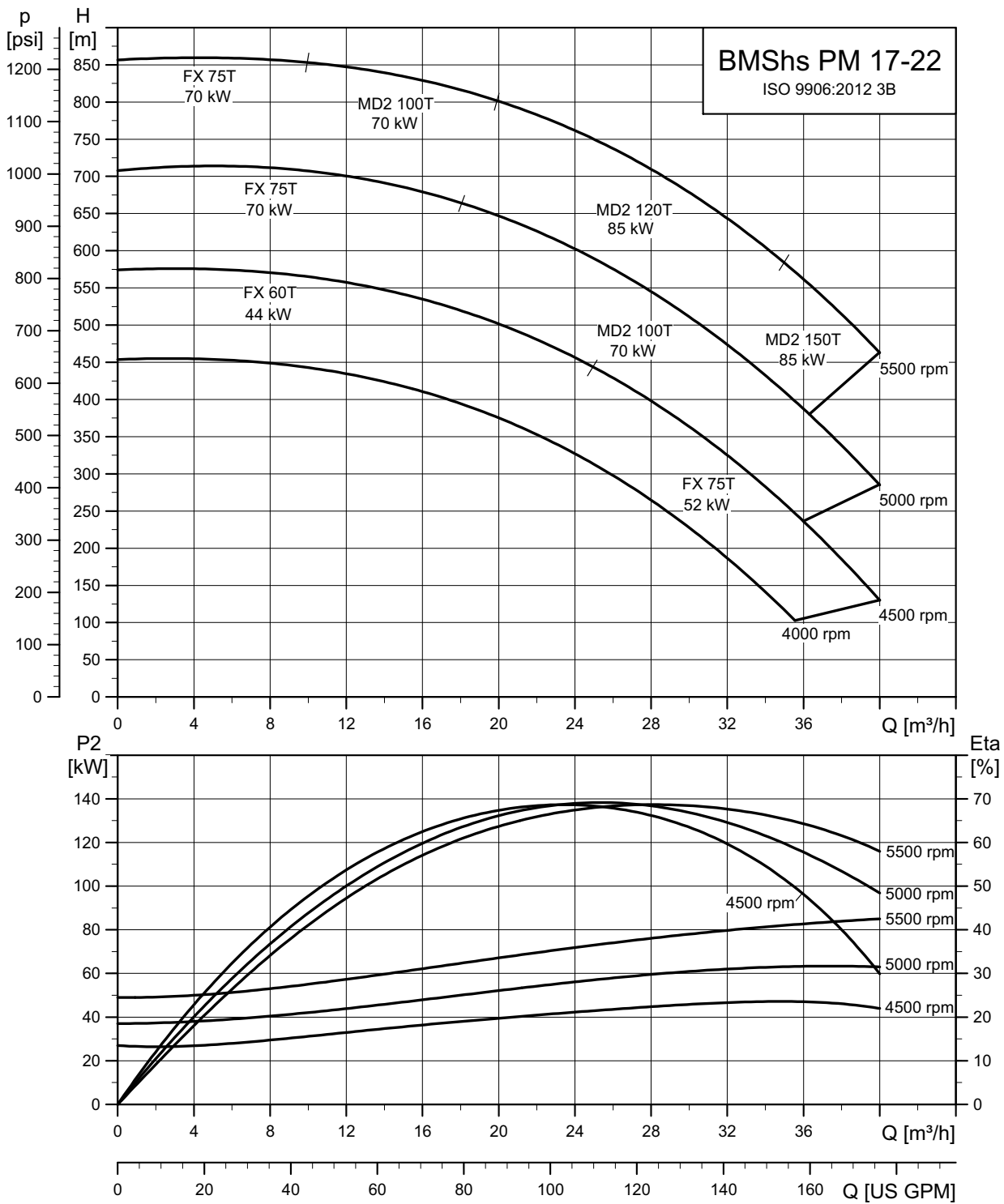

TM05 8114 5115

BMS hs PM, 30-26

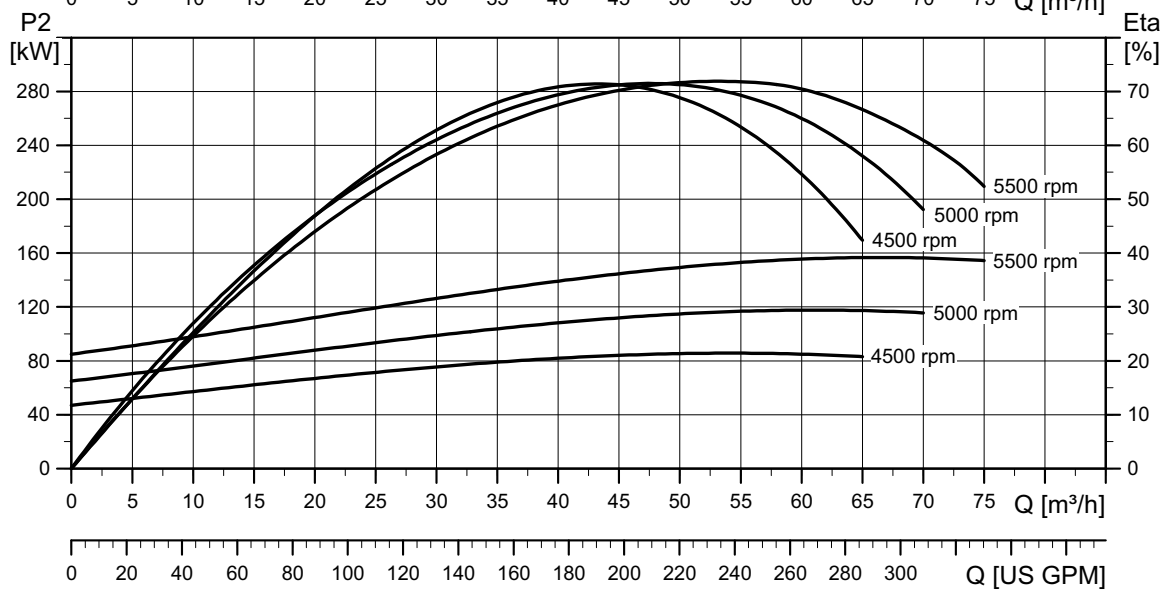
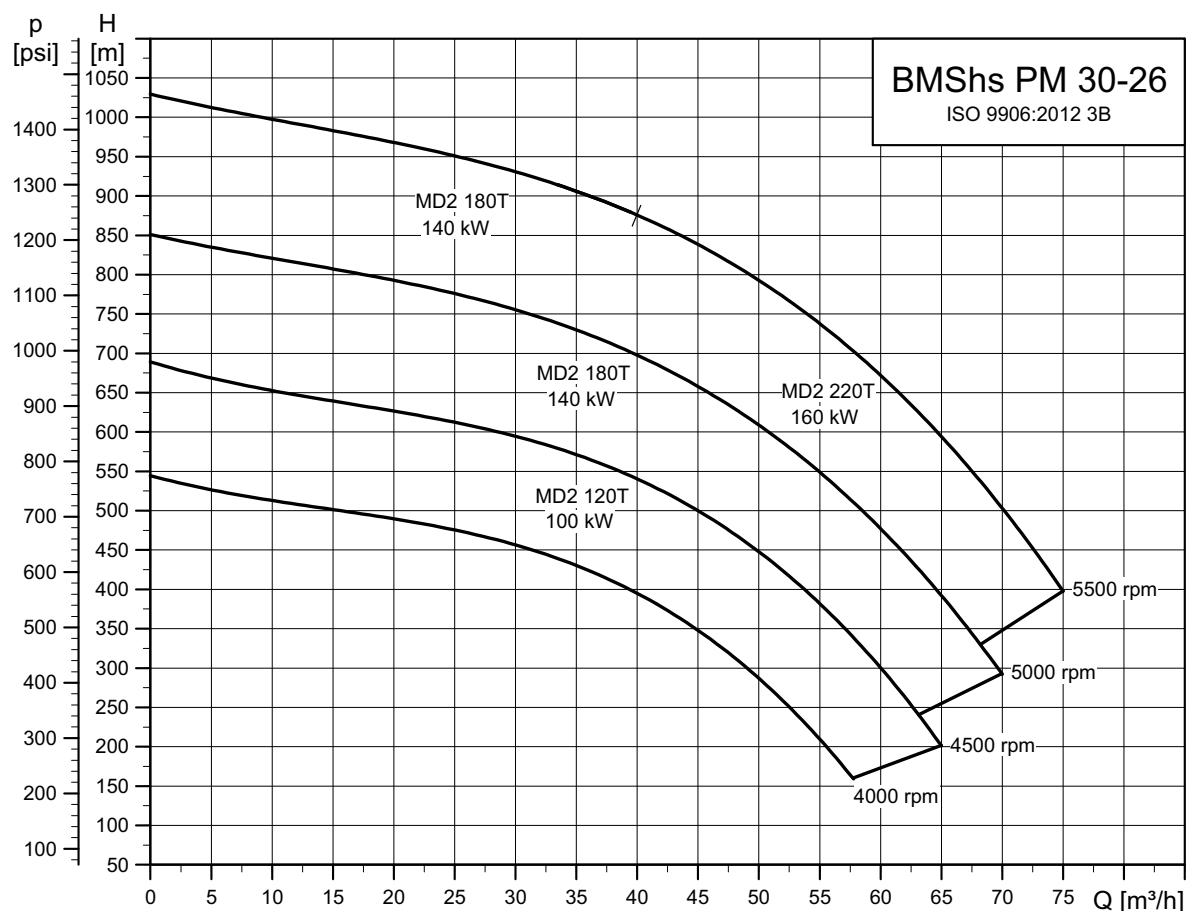

TM05 8237 5115

BMS hs PM, 46-17

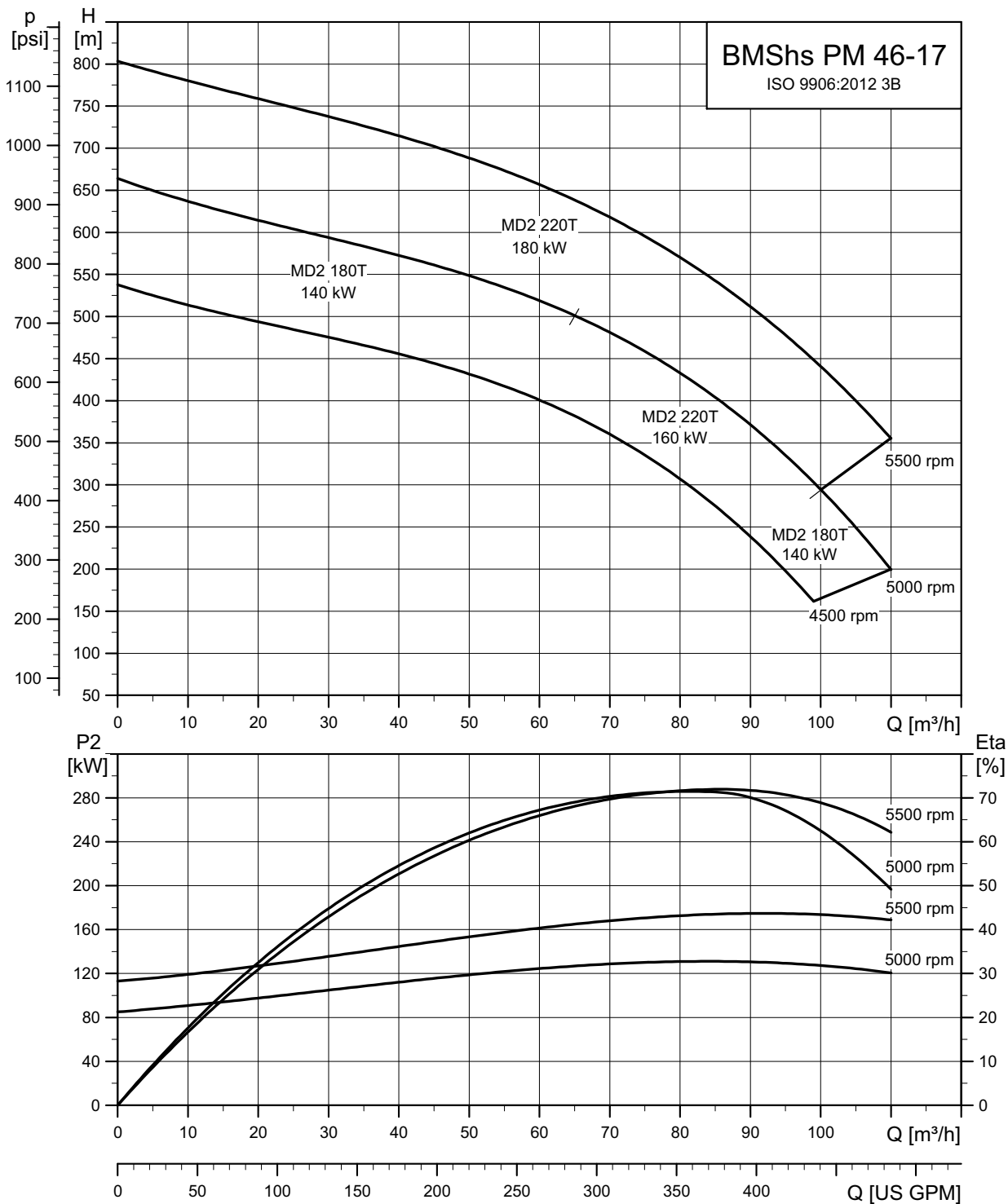

TM05 8238 5115

BMS hs PM, 60-17

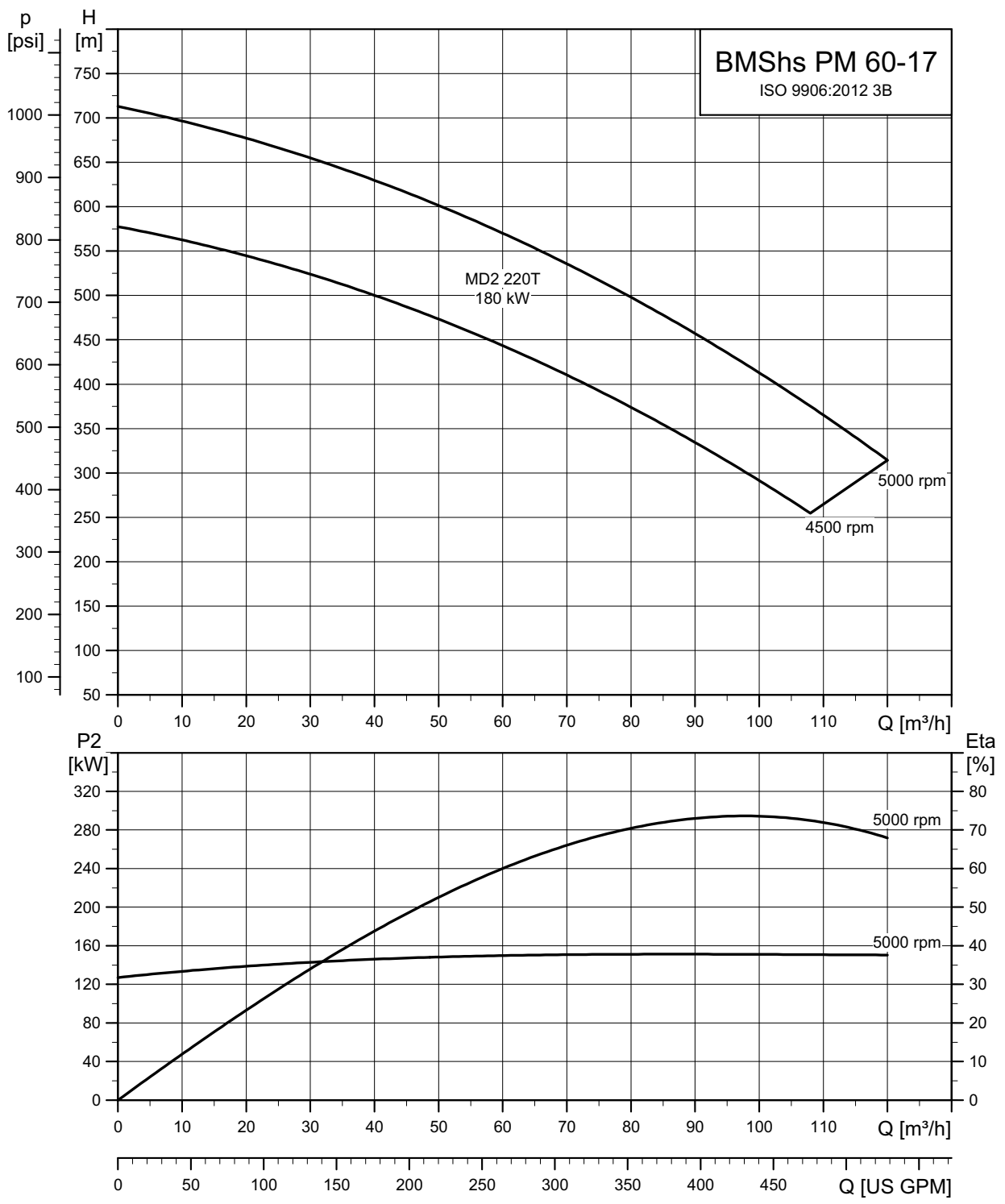

TM05 8239 5115

BMS hs AC, 17-22

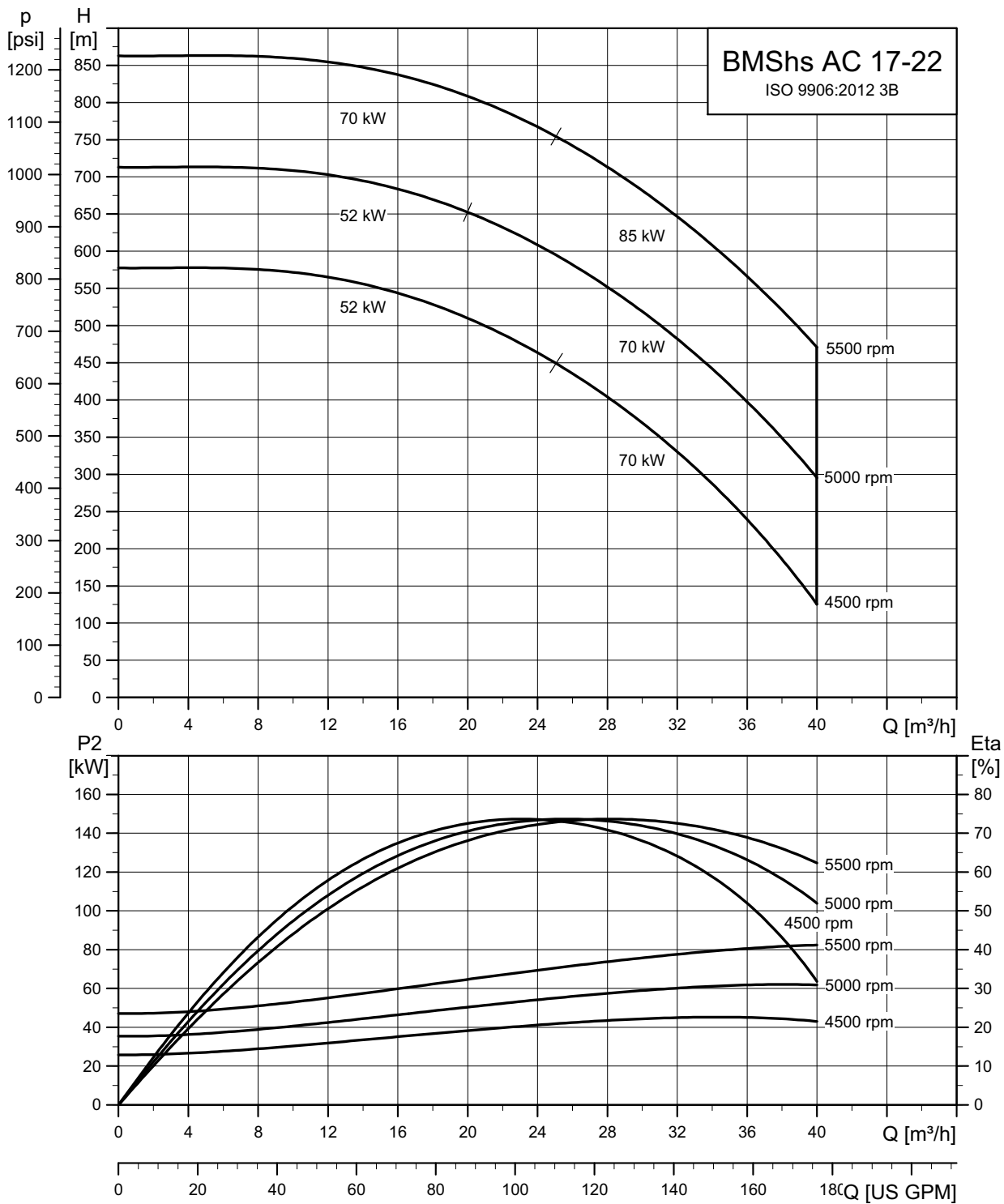

TM06 5600 5115

BMS hs AC, 30-14

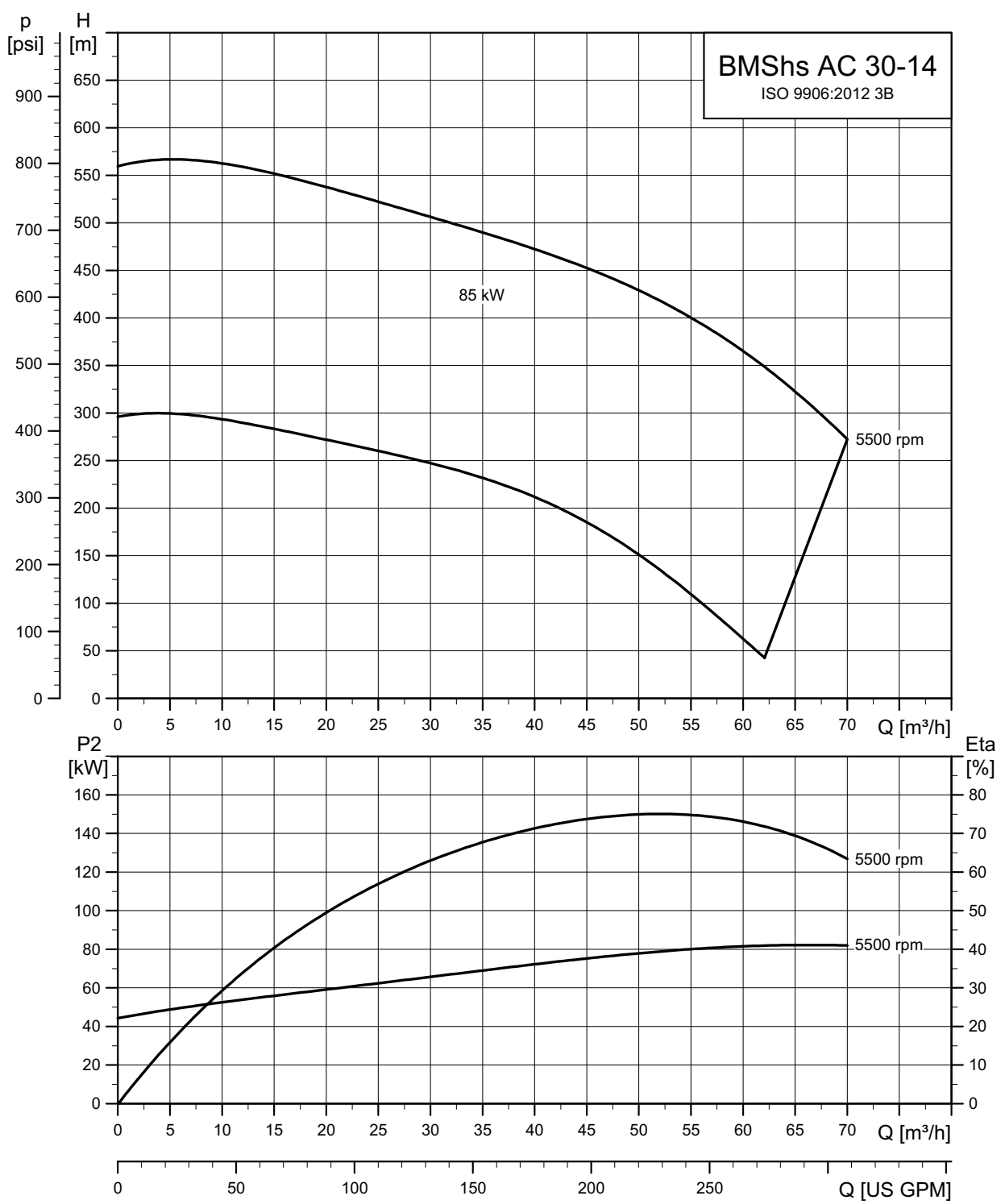

TM06 5601 5115

BMS hs AC, 30-26

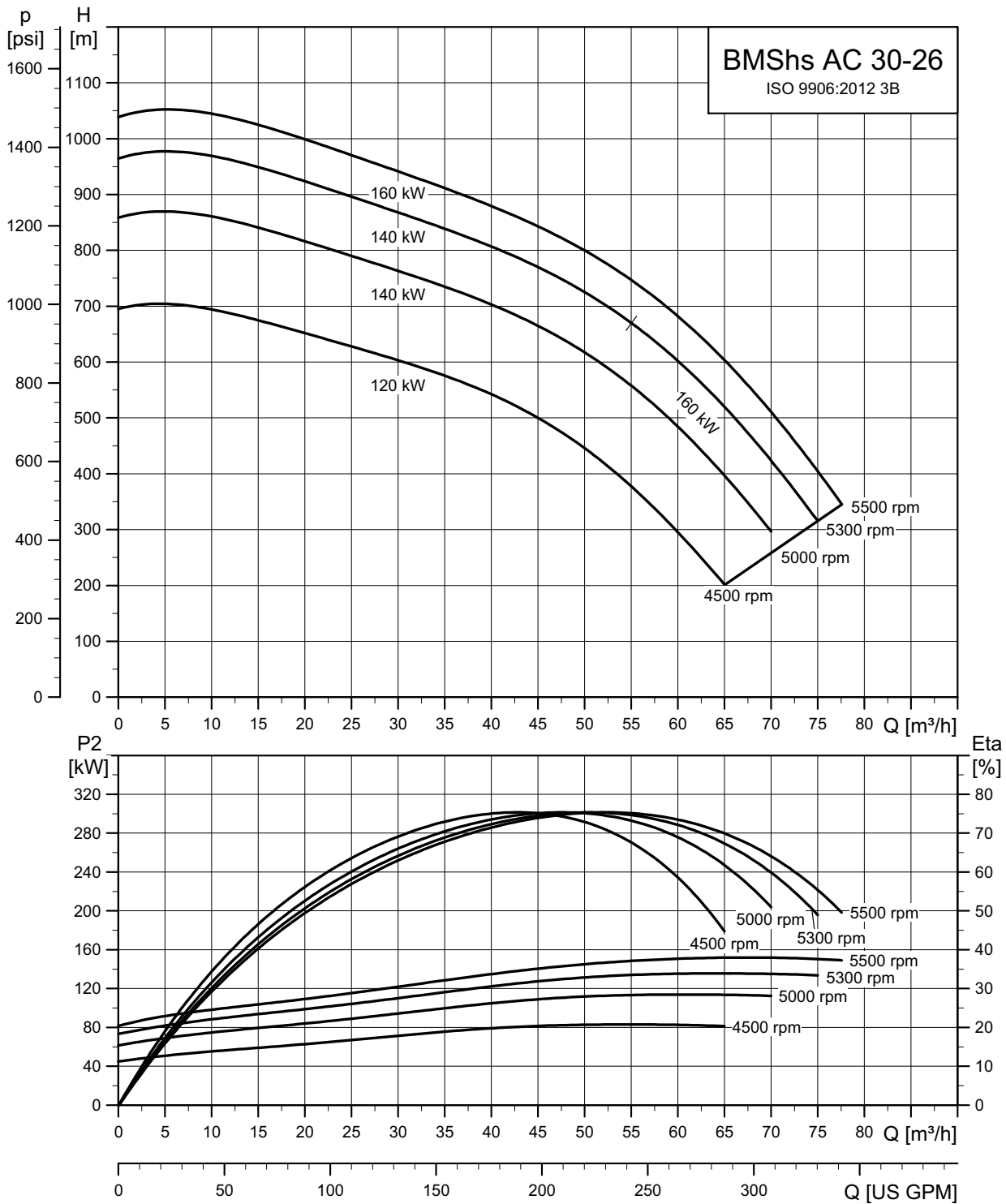

TM06 5602 5115

BMS hs AC, 46-17

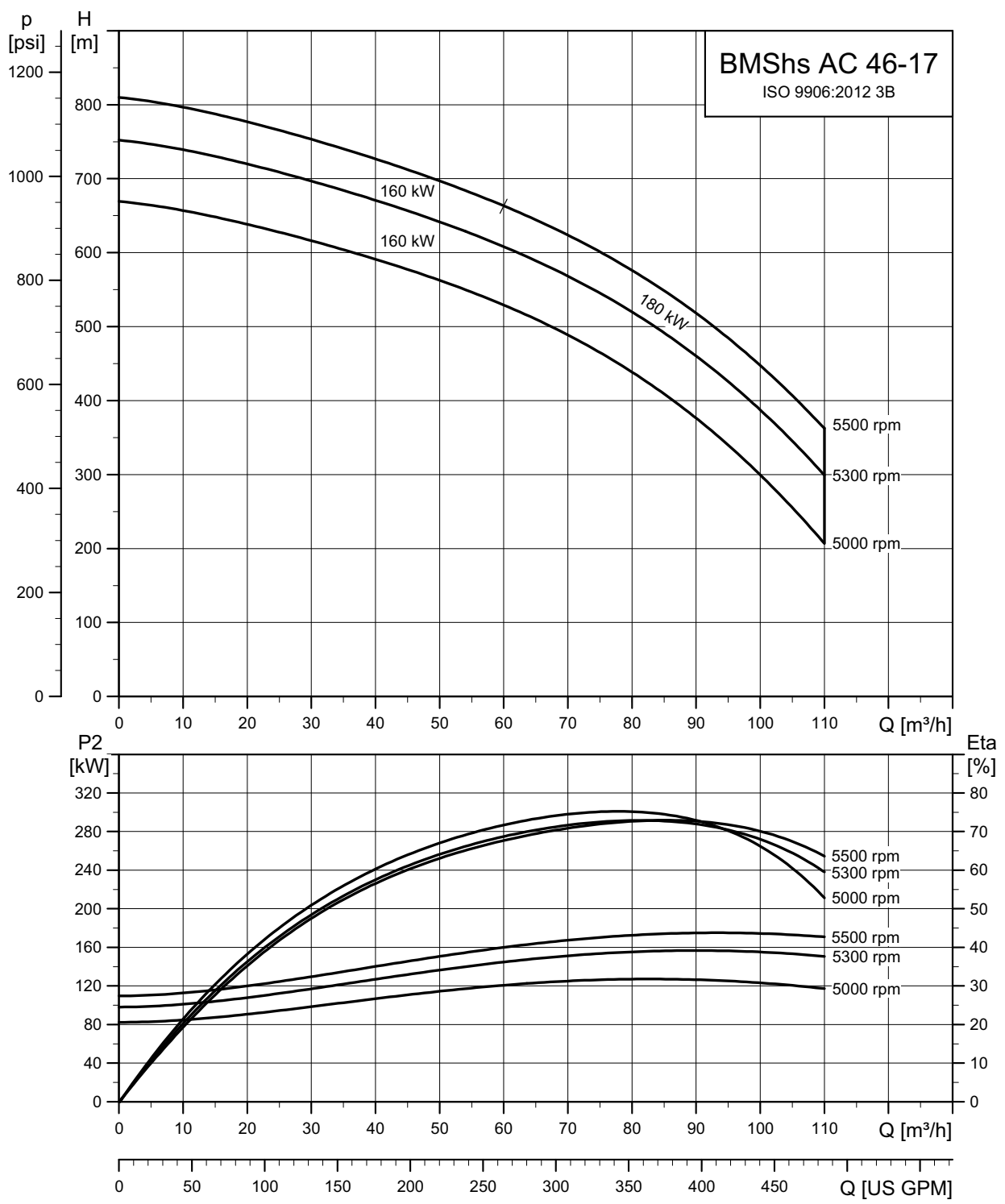

TM06 5603 5115

BMS hs AC, 60-17

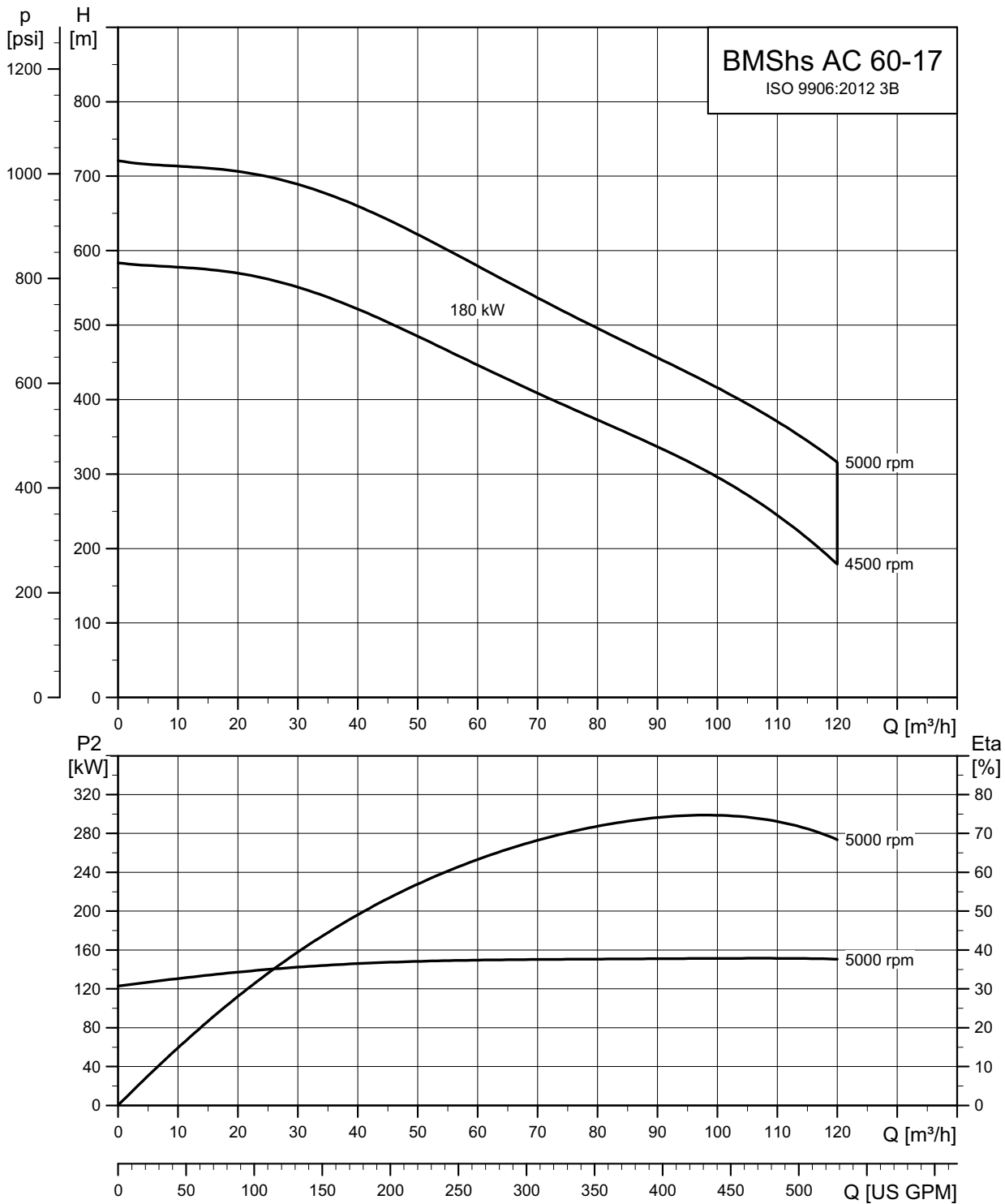

TM06 5604 5115

BMS hp, 17-3, 17-5 and 17-7

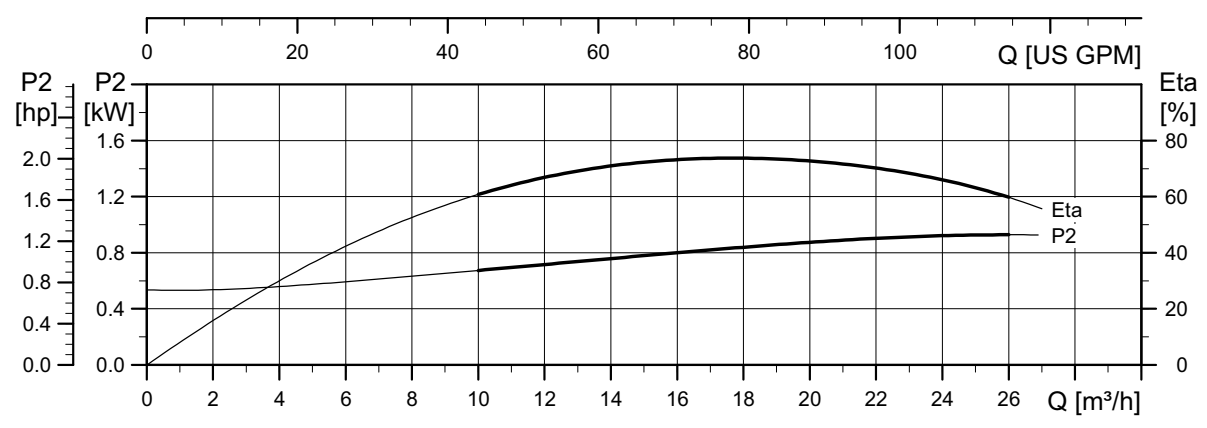
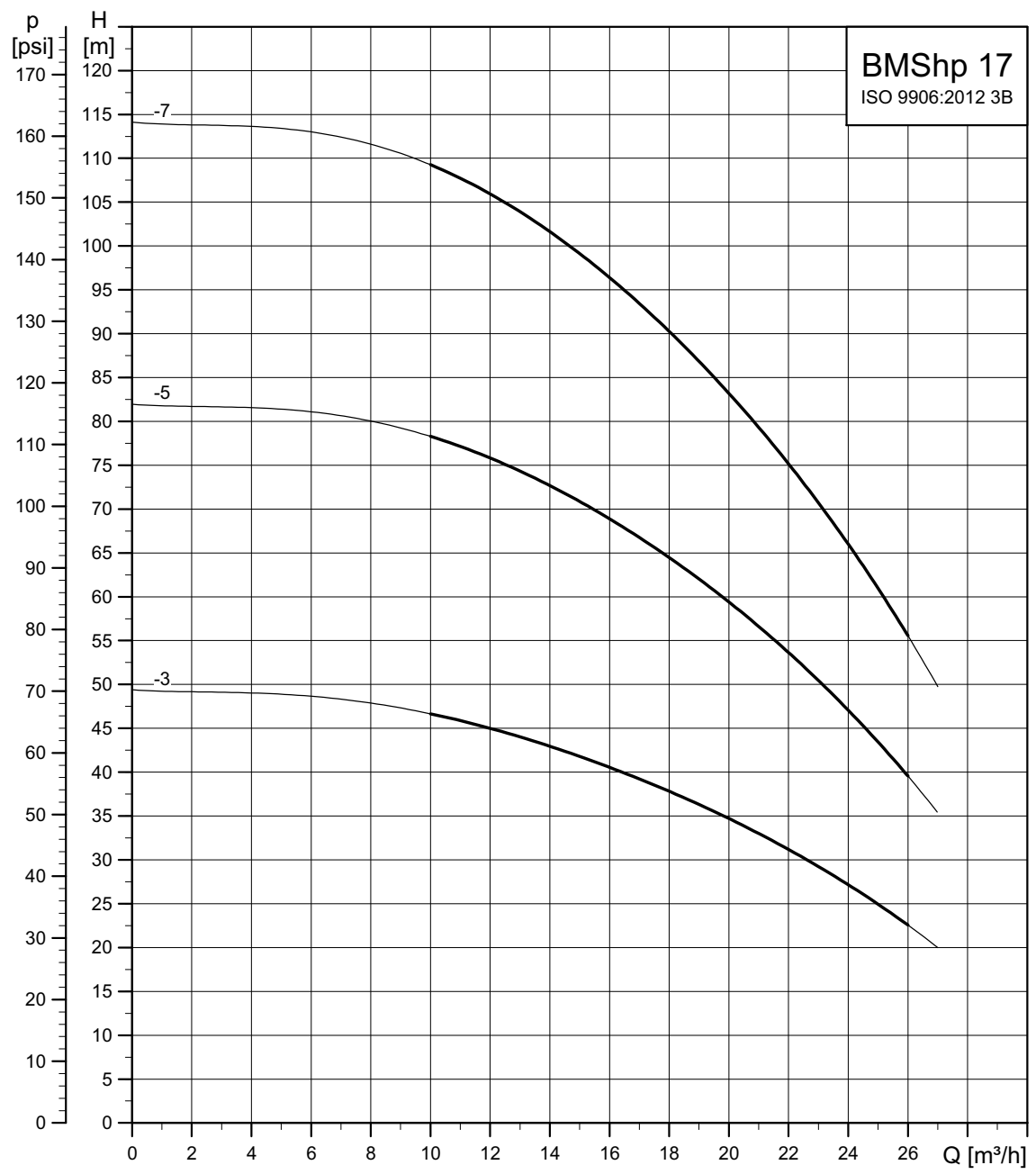

TM06 0725 0814

BMS hp, 30-3, 30-5 and 30-7

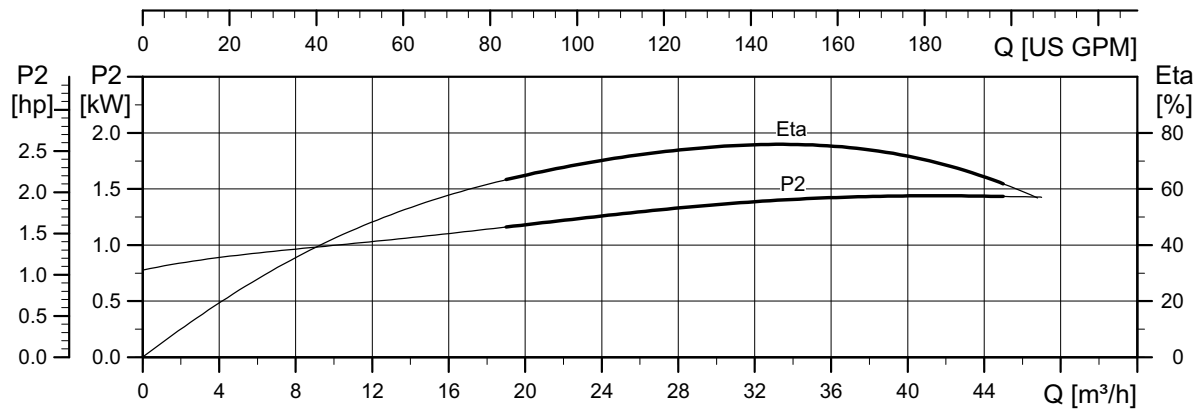
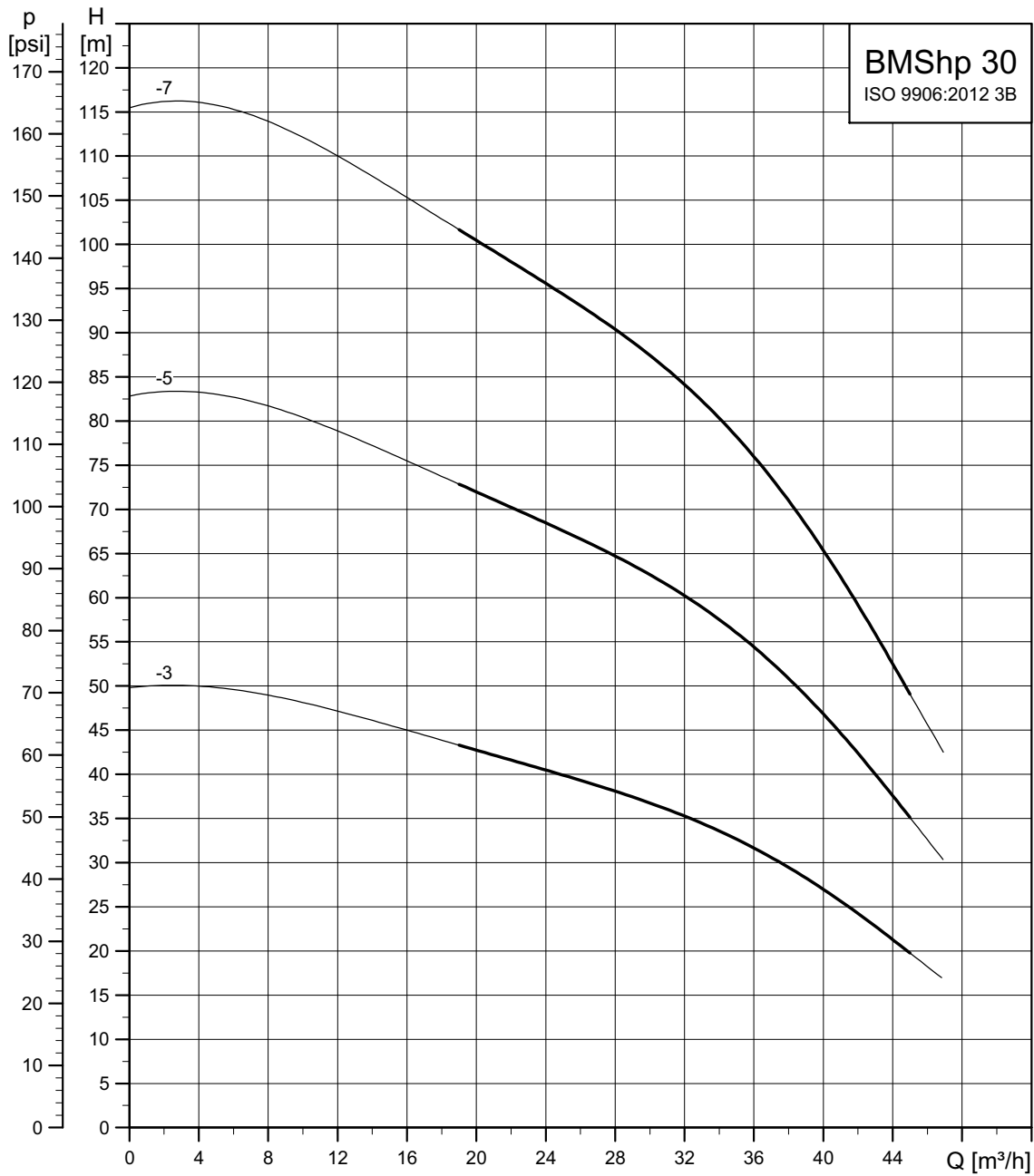

TM06 0726 0814

BMS hp, 46-2, 46-4 and 46-6A

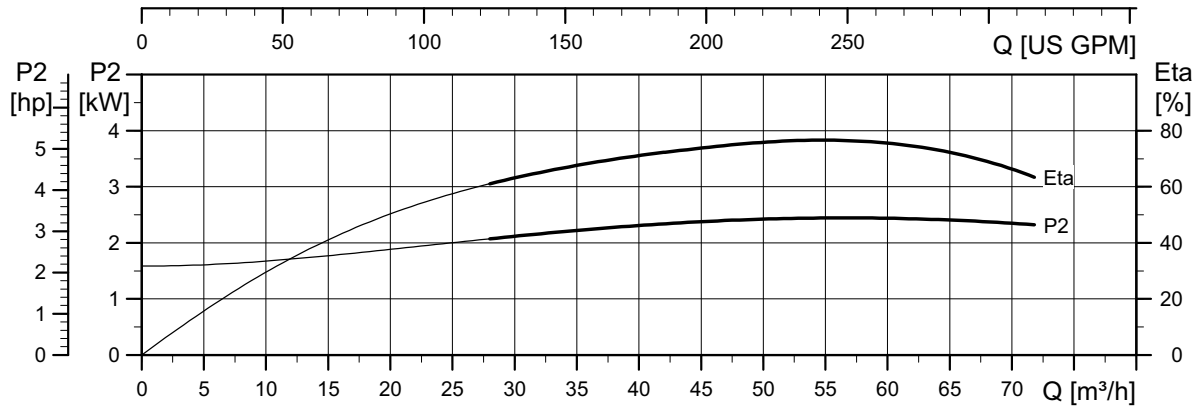
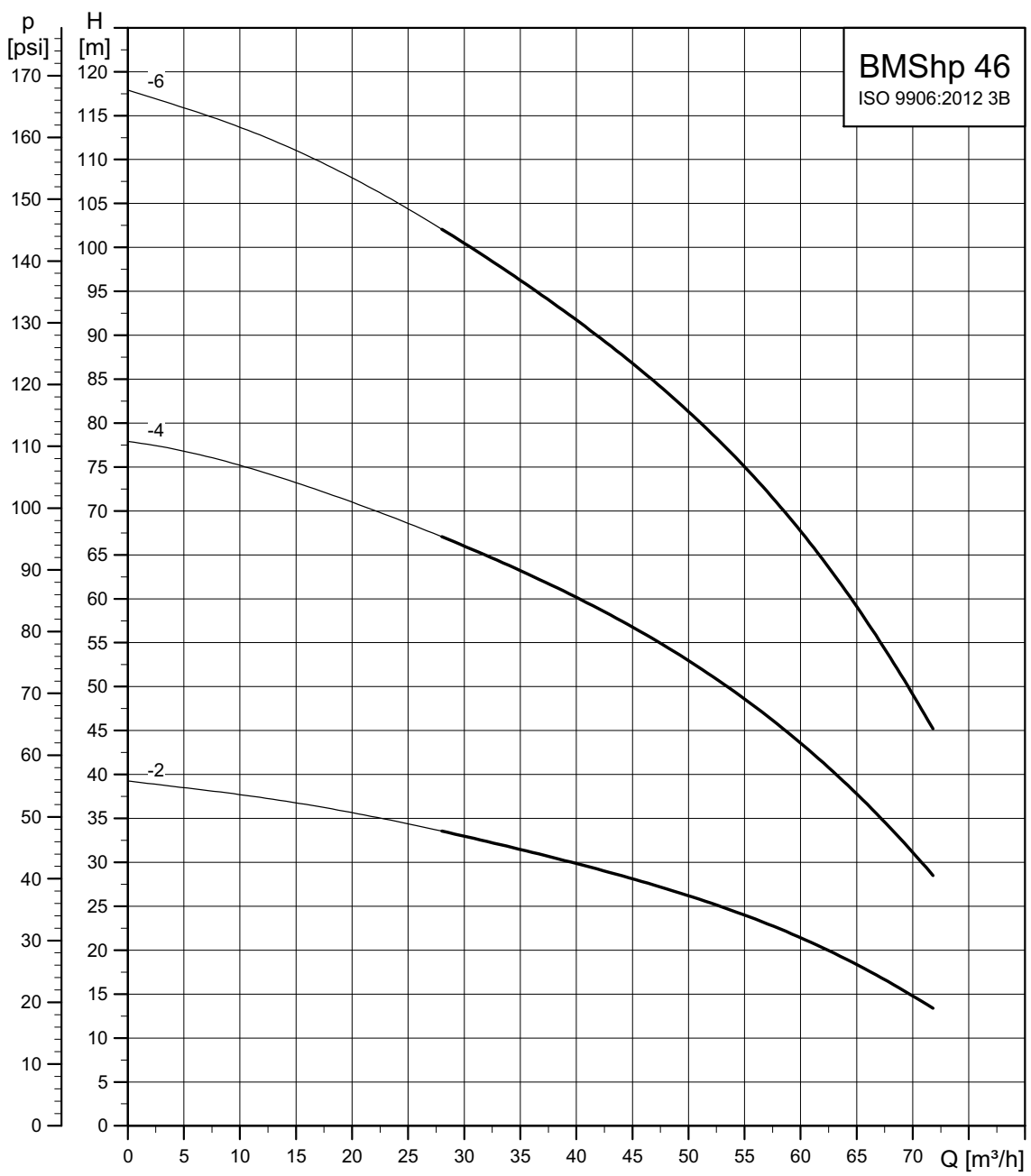

TM06 0727 0814

BMS hp, 60-2, 60-4 and 60-6

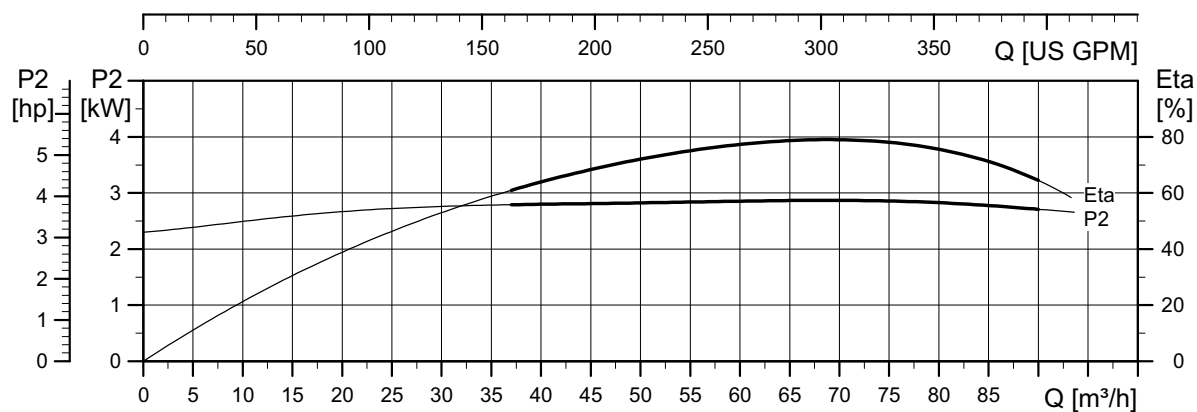
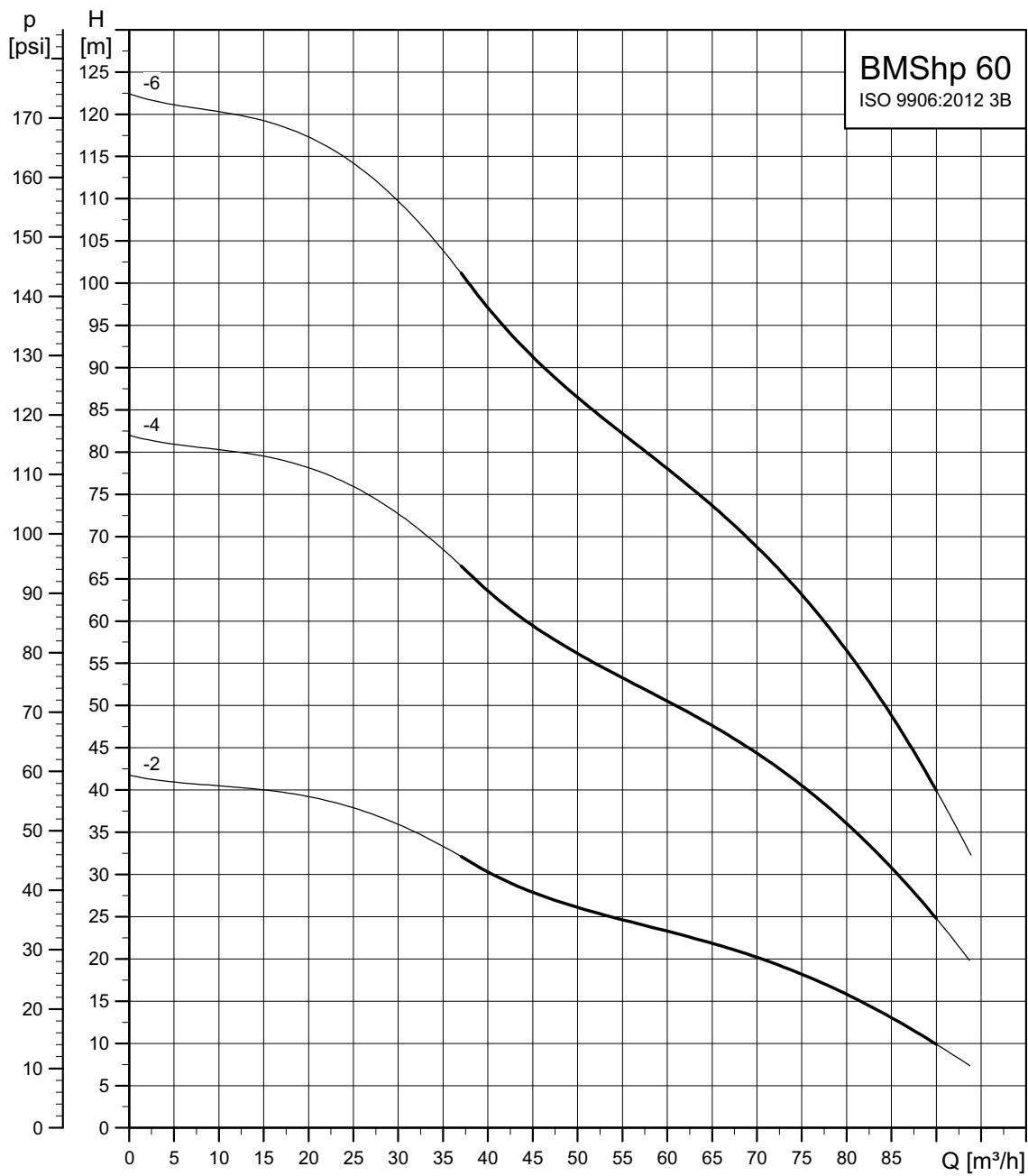

TM06 0728 0814

BMS hp, 77-2A and 77-3

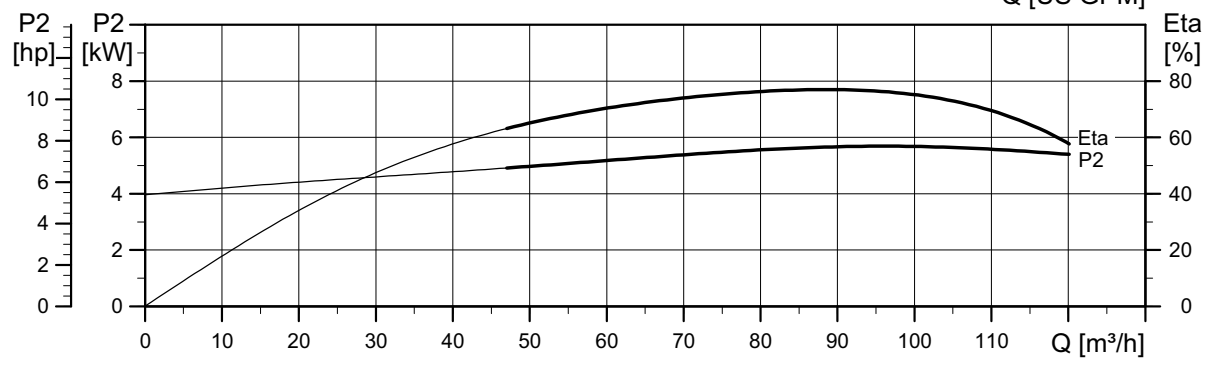
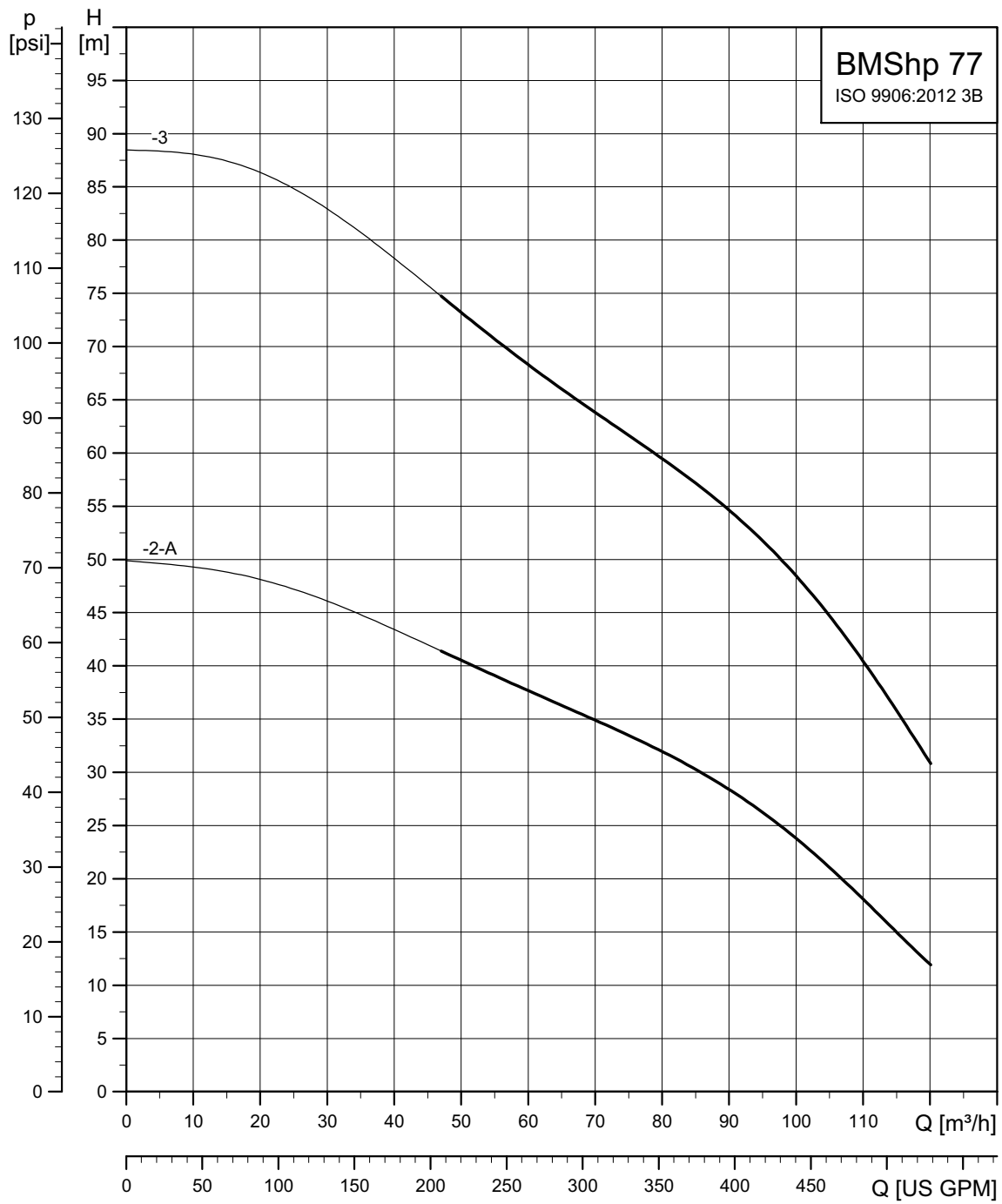

TM06 2412 4314

BMS hp, 95-2 and 95-3

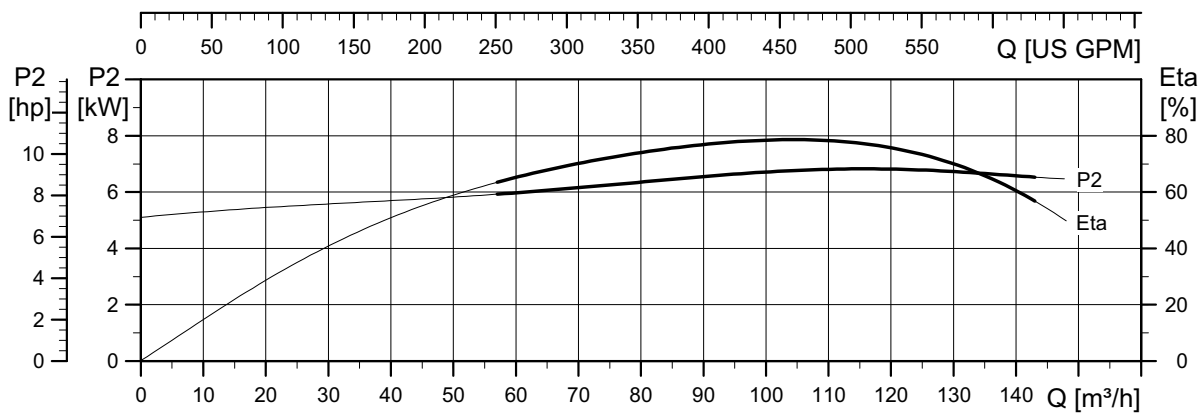
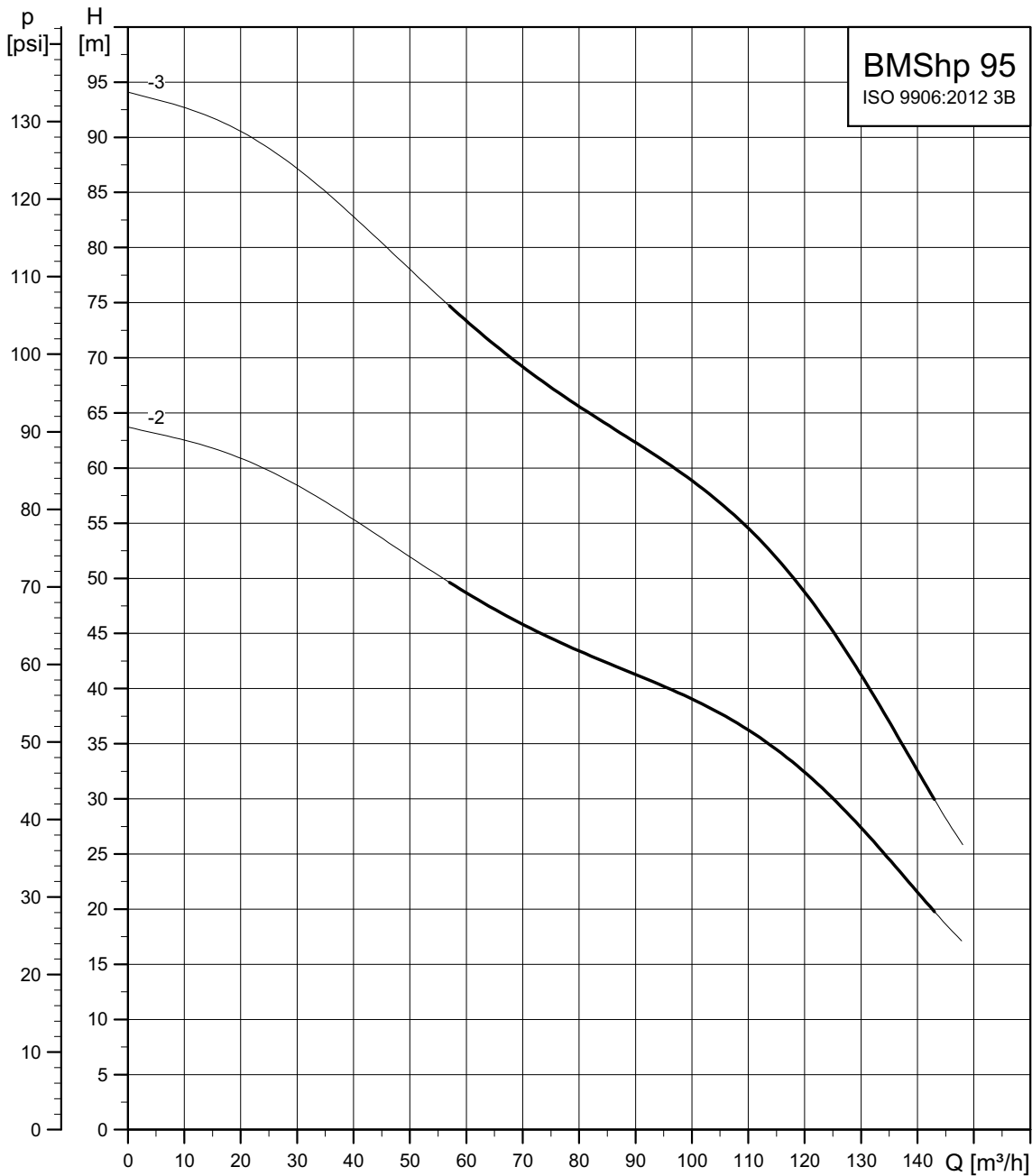

TM06 2412 4314

BMS hp, 125-1 and 125-2AA

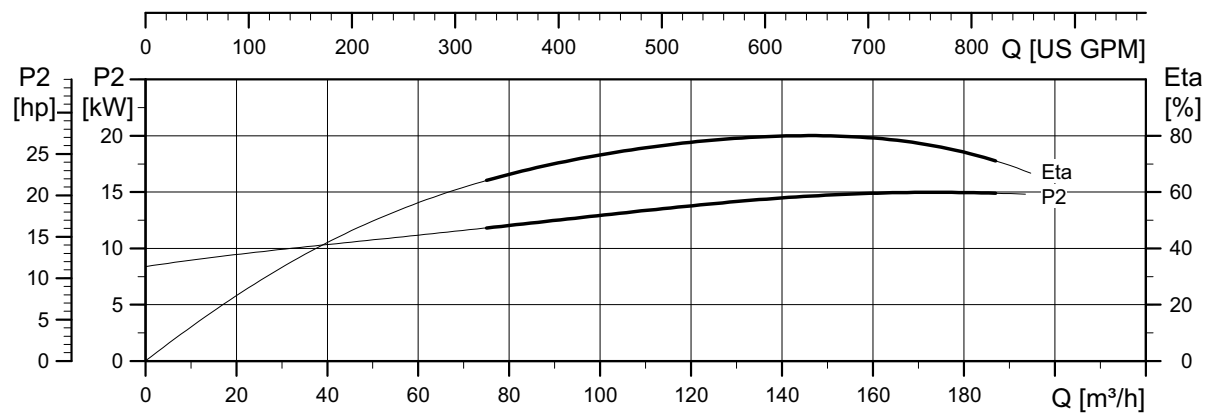
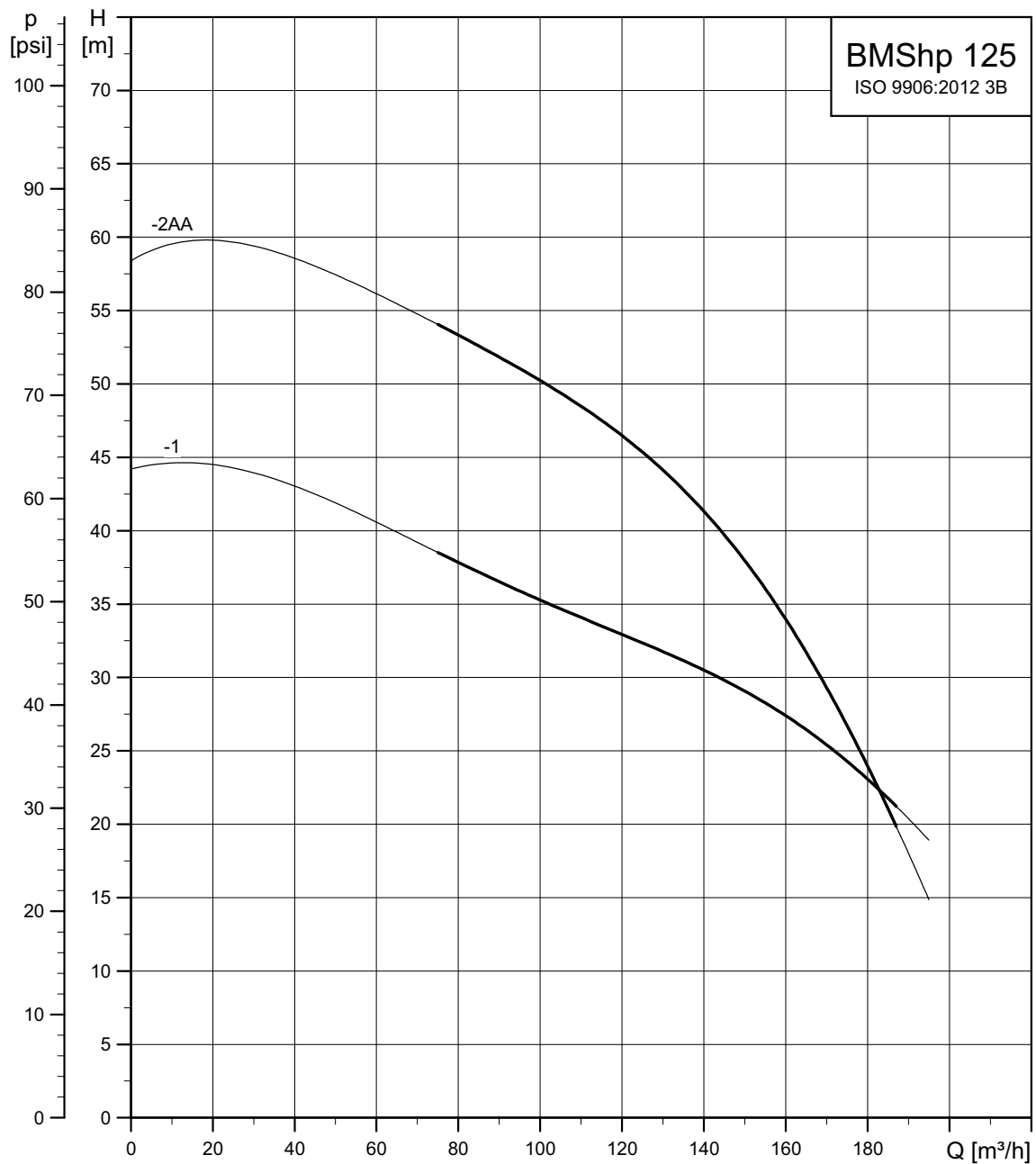

TM06 2414 4314

BMS hp, 160-1A, 160-1 and 160-2AA

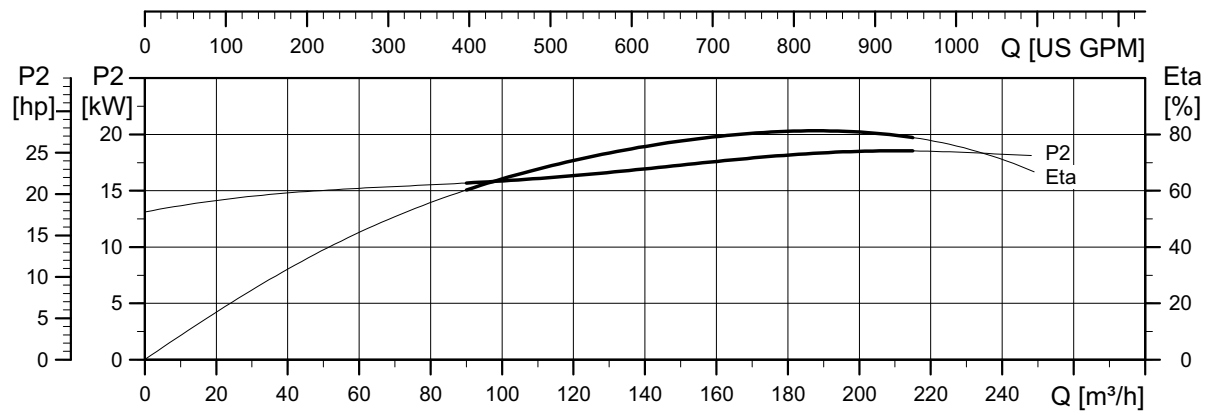
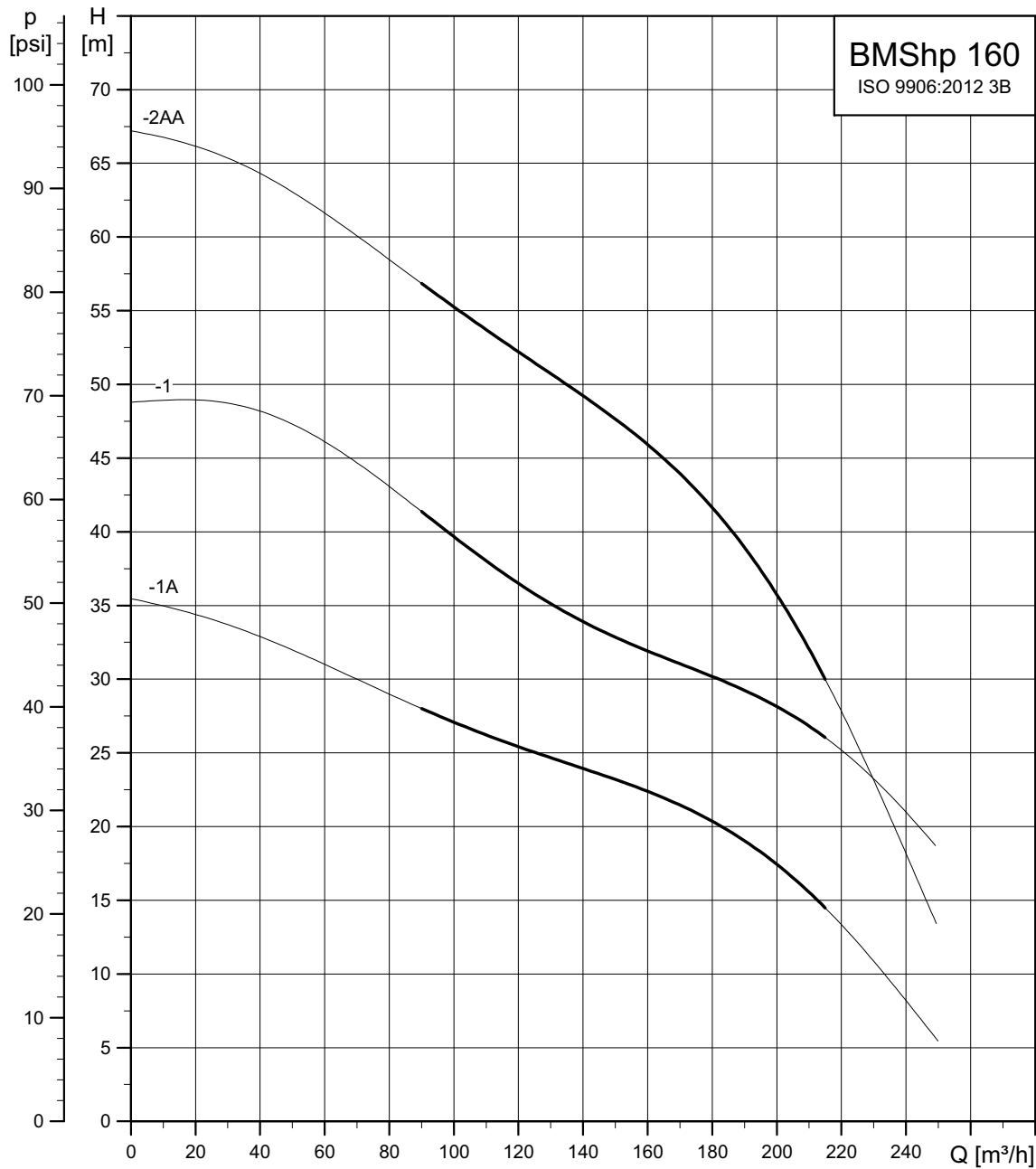

TM06 2415 4314

BMS hp, 215-1A and 215-1

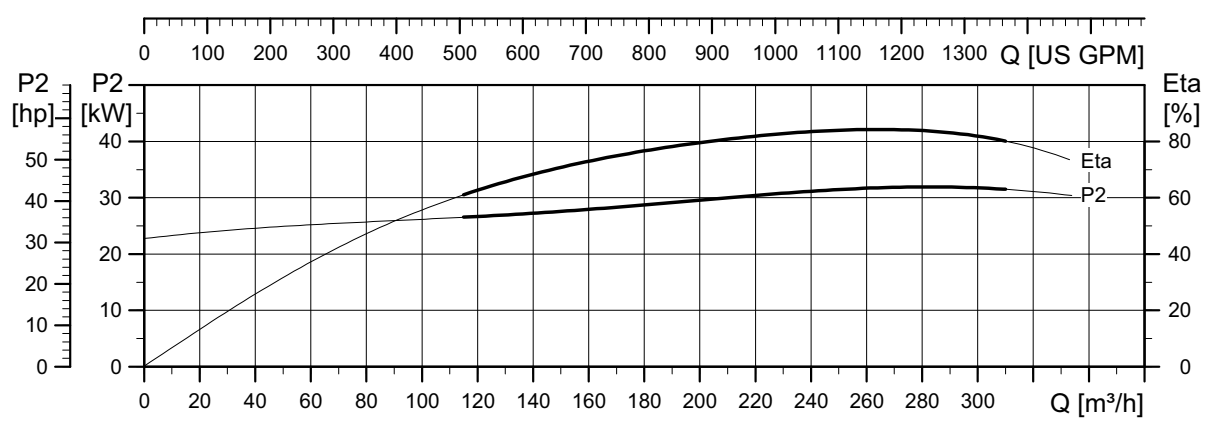
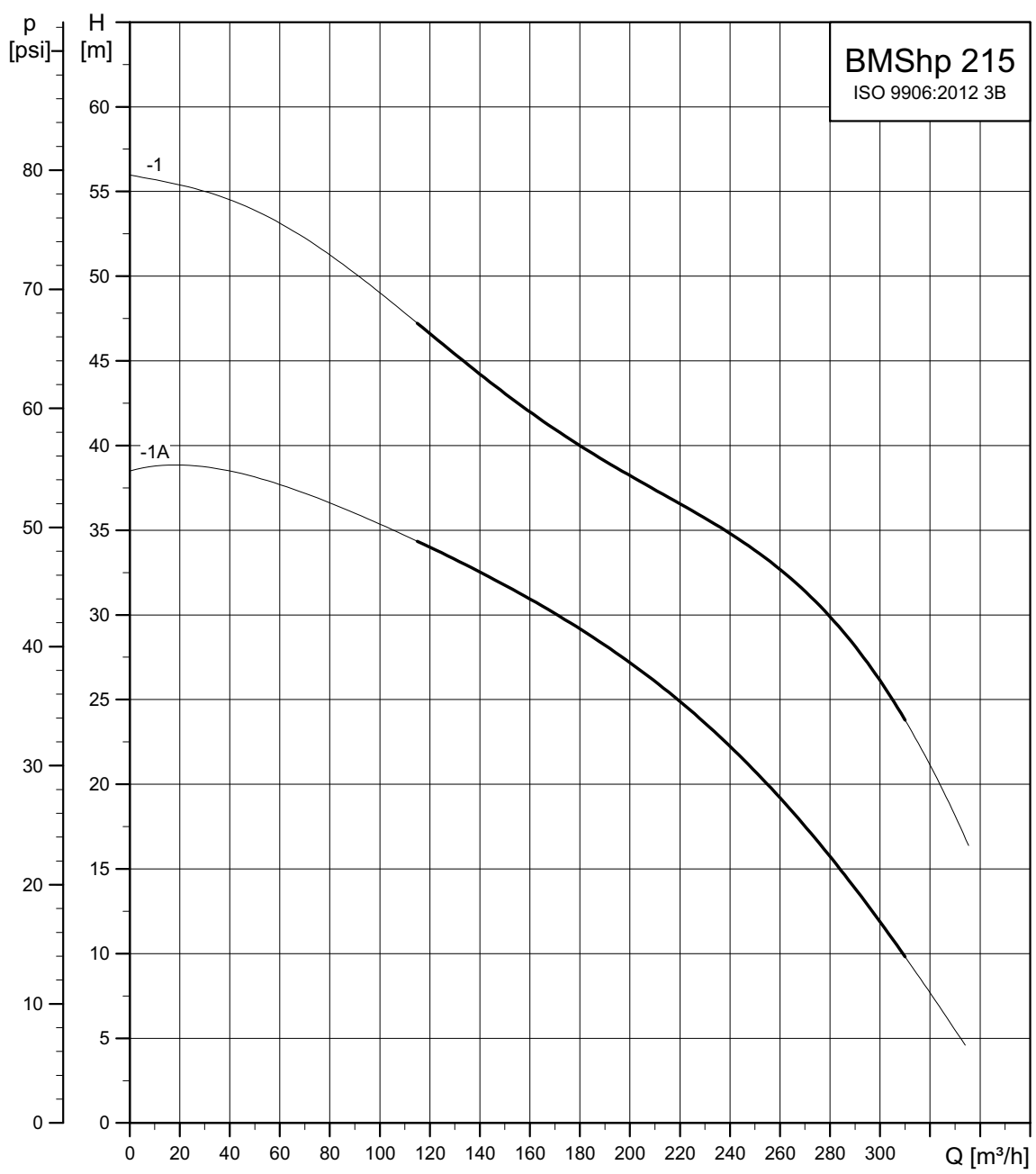

TM06 2416 4314

11. Dimensions and weight

BMS hs PM booster system

BMS hs booster type	Product number	Frequency converter			Max. speed [rpm]	Inlet/outlet horizontal [A]		Inlet/outlet vertical [B]		Centre height [C]		Sleeve diameter [D]		Total length** [E]		Motor dimension [F]	
		Type	[kW]	[hp]		[mm]	[inch]	[mm]	[inch]	[mm]	[inch]	[mm]	[inch]	[mm]	[inch]	[mm]	[inch]
BMS 17-22, HS-E-C-P-A	98467174	FX 75T	70	93.9	5500	170	6.7	139	5.5	250	9.8	168.3	6.6	2737	107.8	305	12
	98467175	MD2MS 100T	70	93.9	5500	170	6.7	139	5.5	250	9.8	168.3	6.6	2737	107.8	305	12
	98467176	MD2MS 120T	85	114	5500	170	6.7	139	5.5	250	9.8	168.3	6.6	2737	107.8	305	12
	98467177	MD2MS 150T	85	114	5500	170	6.7	139	5.5	250	9.8	168.3	6.6	2737	107.8	305	12
	98467178	FX 75T	70	93.9	5000	170	6.7	139	5.5	250	9.8	168.3	6.6	2737	107.8	305	12
	98467179	MD2MS 100T	70	93.9	5000	170	6.7	139	5.5	250	9.8	168.3	6.6	2737	107.8	305	12
	98467180	FX 60T	44	59	4500	170	6.7	139	5.5	250	9.8	168.3	6.6	2737	107.8	305	12
	98467181	FX 75T	52	70	4500	170	6.7	139	5.5	250	9.8	168.3	6.6	2737	107.8	305	12
BMS 30-26, HS-E-C-P-A	98467182	MD2MS 180T	140	187.7	5500	170	6.7	139	5.5	250	9.8	168.3	6.6	3902	153.6	305	12
	98467183	MD2MS 220T	160	214.5	5500	170	6.7	139	5.5	275	10.8	168.3	6.6	4097	107.8	311	12.2
	98467184	MD2MS 180T	140	187.7	5000	170	6.7	139	5.5	250	9.8	168.3	6.6	3902	153.6	305	12
	98467185	MD2MS 120T	100	134	4500	170	6.7	139	5.5	250	9.8	168.3	6.6	3902	153.6	305	12
BMS 46-17, HS-E-C-P-A	98467186	MD2MS 220T	180	241.4	5500	170	6.7	139	5.5	275	10.8	168.3	6.6	3522	161.3	311	12.2
	98467187	MD2MS 180T	140	187.7	5000	170	6.7	139	5.5	250	9.8	168.3	6.6	3327	131.0	305	12
	98467188	MD2MS 220T	160	214.5	5000	170	6.7	139	5.5	275	10.8	168.3	6.6	3522	138.7	311	12.2
BMS 60-17, HS-E-C-P-A	98467190	MD2MS 220T	180	241.4	5000	170	6.7	139	5.5	275	10.8	168.3	6.6	3522	138.7	311	12.2

BMS hs booster type	Product number	Power P2		Motor dimension [G]		Motor dimension [HD]		Dimension [H]		Dimension [I]		Dimension [J]		Dimension [K]		Dimension [L]		Width [W]		Weight* [kg]
		[kW]	[hp]	[mm]	[inch]	[mm]	[inch]	[mm]	[inch]	[mm]	[inch]	[mm]	[inch]	[mm]	[inch]	[mm]	[inch]	[mm]	[inch]	
BMS 17-22, HS-E-C-P-A	98467174	70	93.9	318	12.5	560	22.0	308.5	12.1	1779	70.0	140	5.5	13	0.5	400	15.7	393	15.5	250
	98467175	70	93.9	318	12.5	560	22.0	308.5	12.1	1779	70.0	140	5.5	13	0.5	400	15.7	393	15.5	250
	98467176	85	114	318	12.5	560	22.0	308.5	12.1	1779	70.0	140	5.5	13	0.5	400	15.7	393	15.5	260
	98467177	85	114	318	12.5	560	22.0	308.5	12.1	1779	70.0	140	5.5	13	0.5	400	15.7	393	15.5	260
	98467178	70	93.9	318	12.5	560	22.0	308.5	12.1	1779	70.0	140	5.5	13	0.5	400	15.7	393	15.5	250
	98467179	70	93.9	318	12.5	560	22.0	308.5	12.1	1779	70.0	140	5.5	13	0.5	400	15.7	393	15.5	250
	98467180	44	59	318	12.5	560	22.0	308.5	12.1	1779	70.0	140	5.5	13	0.5	400	15.7	393	15.5	251
	98467181	52	70	318	12.5	560	22.0	308.5	12.1	1779	70.0	140	5.5	13	0.5	400	15.7	393	15.5	251
BMS 30-26, HS-E-C-P-A	98467182	140	187.7	318	12.5	621	24.4	308.5	12.1	2944	115.9	140	5.5	13	0.5	400	15.7	393	15.5	348
	98467183	160	214.5	356	14	680	26.8	308.5	12.1	2966	116.8	140	5.5	13	0.5	400	15.7	480	18.9	485
	98467184	140	187.7	318	12.5	621	24.4	308.5	12.1	2944	115.9	140	5.5	13	0.5	400	15.7	393	15.5	348
	98467185	100	134	318	12.5	560	22.0	308.5	12.1	2944	115.9	140	5.5	13	0.5	400	15.7	393	15.5	336
BMS 46-17, HS-E-C-P-A	98467186	180	241.4	356	14	680	26.8	308.5	12.1	2391	94.1	140	5.5	13	0.5	400	15.7	480	18.9	478
	98467187	140	187.7	318	12.5	621	24.4	308.5	12.1	2369	93.3	140	5.5	13	0.5	400	15.7	393	15.5	341
	98467188	160	214.5	356	14	680	26.8	308.5	12.1	2391	94.1	140	5.5	13	0.5	400	15.7	480	18.9	478
BMS 60-17, HS-E-C-P-A	98467190	180	241.4	356	14	680	26.8	308.5	12.1	2391	94.1	140	5.5	13	0.5	400	15.7	480	18.9	478

* Weight without frequency converter (POWERDRIVE MD or FX).
 ** Length [E] without service connector.

Dimensional sketch

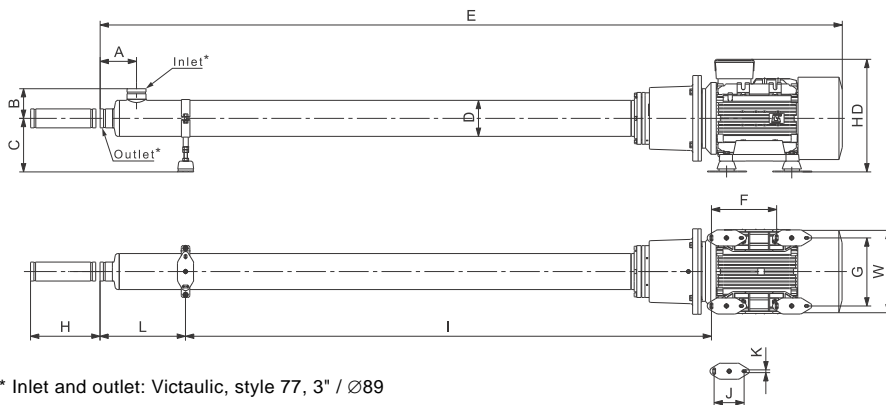

* Inlet and outlet: Victaulic, style 77, 3" / Ø89

Fig. 26 BMS hs PM booster system with service connector

Dimensions and weight

TM05 9244 3613

Frequency converter for PM motor

Type	Dimensions						Weight [kg]
	H		W		D		
	[mm]	[inch]	[mm]	[inch]	[mm]	[inch]	
FX 60T	1200	47.2	600	23.6	500	19.7	49
FX 75T	1200	47.2	600	23.6	500	19.7	50
MD2MS 100T	1200	47.2	480	18.9	560	22	225
MD2MS 120T	1200	47.2	480	18.9	560	22	
MD2MS 150T	1200	47.2	480	18.9	560	22	
MD2MS 180T	1710	67.3	480	18.9	560	22	
MD2MS 220T	1710	67.3	480	18.9	560	22	260



Gr-1015353

Service connector

Use the service connector to ensure easy access for maintenance. The length of the service connector is 312 mm.



TM05 9766 4413

Fig. 27 Service connector

BMS hs AC booster system

BMS hs booster type	Product number	Power P2			Inlet/outlet horizontal [A]		Inlet/outlet vertical [B]		Centre height [C]		Sleeve diameter [D]		Total length** [E]		Motor dimension [F]		Motor dimension [G]	
		[kW]	[hp]	[rpm]	[mm]	[inch]	[mm]	[inch]	[mm]	[inch]	[mm]	[inch]	[mm]	[inch]	[mm]	[inch]	[mm]	[inch]
BMS 17-22 HS-B-C-P-A	99022832	52	69.7	5000	170	6.7	139	5.5	250	9.8	168.3	6.6	2752	108.3	305	12	318	12.5
	99022843	70	93.9	5500	170	6.7	139	5.5	275	10.8	168.3	6.6	2768	109.0	311	12.2	356	14
	99022844	85	114	5500	170	6.7	139	5.5	275	10.8	168.3	6.6	2768	109.0	311	12.2	356	14
BMS 30-14 HS-B-C-P-A	99022845	85	114	5500	170	6.7	139	5.5	275	10.8	168.3	6.6	2781	109.5	311	12.2	356	14
BMS 30-26 HS-B-C-P-A	99022846	120	160.9	4500	170	6.7	139	5.5	275	10.8	168.3	6.6	3993	157.2	311	12.2	356	14
	99022847	140	187.7	5500	170	6.7	139	5.5	275	10.8	168.3	6.6	4073	160.4	311	12.2	356	14
	99022848	160	214.6	5500	170	6.7	139	5.5	300	11.8	168.3	6.6	4135	162.8	349	13.7	406	16
BMS 46-17 HS-B-C-P-A	99022849	160	214.6	5500	170	6.7	139	5.5	300	11.8	168.3	6.6	3560	140.2	349	13.7	406	16
	99059893	180	241.4	5500	170	6.7	139	5.5	300	11.8	168.3	6.6	3560	140.2	349	13.7	406	16
BMS 60-17 HS-B-C-P-A	99022850	180	241.4	5000	170	6.7	139	5.5	300	11.8	168.3	6.6	3560	140.2	349	13.7	406	16

BMS hs booster type	Product number	Power P2			Motor dimension [HD]		Dimension [H]		Dimension [I]		Dimension [J]		Dimension [K]		Dimension [L]		Width [W]		Weight* [kg]
		[kW]	[hp]	[rpm]	[mm]	[inch]	[mm]	[inch]	[mm]	[inch]	[mm]	[inch]	[mm]	[inch]	[mm]	[inch]	[mm]	[inch]	
BMS 17-22 HS-B-C-P-A	99022832	52	69.7	5000	565	22.2	308.5	12.1	1779	69.7	140	5.5	13	0.5	400	15.7	393	15.5	389
	99022843	70	93.9	5500	683	26.9	308.5	12.1	1801	70.9	140	5.5	13	0.5	400	15.7	431	17	437
	99022844	85	114	5500	683	26.9	308.5	12.1	1801	70.9	140	5.5	13	0.5	400	15.7	431	17	442
BMS 30-14 HS-B-C-P-A	99022845	85	114	5500	683	26.9	308.5	12.1	1814	71.4	140	5.5	13	0.5	400	15.7	431	17	440
	99022846	120	160.9	4500	683	26.9	308.5	12.1	2966	116.8	140	5.5	13	0.5	400	15.7	431	17	511
BMS 30-26 HS-B-C-P-A	99022847	140	187.7	5500	683	26.9	308.5	12.1	2966	116.8	140	5.5	13	0.5	400	15.7	431	17	606
	99022848	160	214.6	5500	802	31.6	308.5	12.1	3016	118.7	140	5.5	13	0.5	400	15.7	481	18.9	643
	99059893	180	241.4	5500	802	31.6	308.5	12.1	2441	96.1	140	5.5	13	0.5	400	15.7	481	18.9	636
BMS 60-17 HS-B-C-P-A	99022850	180	241.4	5000	802	31.6	308.5	12.1	2441	96.1	140	5.5	13	0.5	400	15.7	481	18.9	646

* Weight without frequency converter (POWERDRIVE MD or FX).

** Length [E] without service connector.

Dimensional sketch

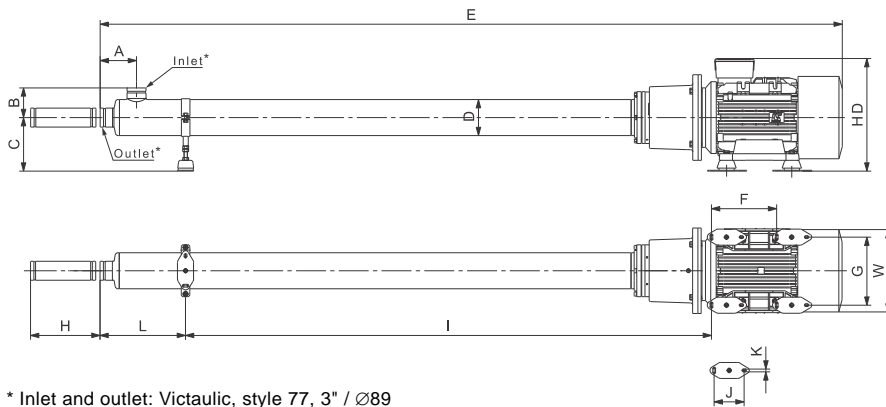

* Inlet and outlet: Victaulic, style 77, 3" / Ø89

Fig. 28 BMS hs AC booster system with service connector

TM05 9244 3613

BMS hp MG booster system 6"

BMS hp	Product number	Inlet/outlet horizontal [A]		Inlet/outlet vertical [B]		Centre height [C]		Sleeve diameter [D]		Total length [E]		Motor dimension [F]	
		[mm]	[inch]	[mm]	[inch]	[mm]	[inch]	[mm]	[inch]	[mm]	[inch]	[mm]	[inch]
BMS 17-3 HP-A-C-P-A	98872087	170	6.7	139.0	5.5	100	3.9	168.3	6.6	1281	50.4	140	5.5
BMS 17-5 HP-A-C-P-A	98872088	170	6.7	139.0	5.5	132	5.2	168.3	6.6	1458	57.4	140	5.5
BMS 17-7 HP-A-C-P-A	98872090	170	6.7	139.0	5.5	132	5.2	168.3	6.6	1567	61.7	140	5.5
BMS 30-3 HP-A-C-P-A	98872101	170	6.7	139.0	5.5	132	5.2	168.3	6.6	1432	56.4	140	5.5
BMS 30-5 HP-A-C-P-A	98872102	170	6.7	139.0	5.5	132	5.2	168.3	6.6	1624	63.9	140	5.5
BMS 30-7 HP-A-C-P-A	98872103	170	6.7	139.0	5.5	160	6.3	168.3	6.6	2018	79.4	210	8.3
BMS 46-2 HP-A-C-P-A	98872104	170	6.7	139.0	5.5	132	5.2	168.3	6.6	1382	54.4	140	5.5
BMS 46-4 HP-A-C-P-A	98872105	170	6.7	139.0	5.5	160	6.3	168.3	6.6	1798	70.8	210	8.3
BMS 46-6A HP-A-C-P-A	98872106	170	6.7	139.0	5.5	160	6.3	168.3	6.6	2024	79.7	210	8.3
BMS 60 -2 HP-A-C-P-A	98872107	170	6.7	139.0	5.5	132	5.2	168.3	6.6	1370	53.9	140	5.5
BMS 60 -4 HP-A-C-P-A	98872109	170	6.7	139.0	5.5	160	6.3	168.3	6.6	1798	70.8	210	8.3
BMS 60 -6 HP-A-C-P-A	98872110	170	6.7	139.0	5.5	160	6.3	168.3	6.6	2068	81.4	254	10.0

BMS hp	Product number	Motor dimension [G]		Motor dimension [HD]		Dimension [K]		Dimension [M]		Width [W]		Weight [kg]
		[mm]	[inch]	[mm]	[inch]	[mm]	[inch]	[mm]	[inch]	[mm]	[inch]	
BMS 17-3 HP-A-C-P-A	98872087	160	6.3	255	10.0	12	0.5	135	5.3	270	10.6	96
BMS 17-5 HP-A-C-P-A	98872088	216	8.5	284	11.2	12	0.5	150	5.9	300	11.8	96
BMS 17-7 HP-A-C-P-A	98872090	216	8.5	309	12.2	12	0.5	150	5.9	300	11.8	135
BMS 30-3 HP-A-C-P-A	98872101	216	8.5	284	11.2	12	0.5	150	5.9	300	11.8	120
BMS 30-5 HP-A-C-P-A	98872102	216	8.5	309	12.2	12	0.5	150	5.9	300	11.8	136
BMS 30-7 HP-A-C-P-A	98872103	254	10.0	379	14.9	15	0.6	175	6.9	350	13.8	189
BMS 46-2 HP-A-C-P-A	98872104	216	8.5	284	11.2	12	0.5	150	5.9	300	11.8	119
BMS 46-4 HP-A-C-P-A	98872105	254	10.0	379	14.9	15	0.6	175	6.9	350	13.8	183
BMS 46-6A HP-A-C-P-A	98872106	254	10.0	379	14.9	15	0.6	175	6.9	350	13.8	203
BMS 60 -2 HP-A-C-P-A	98872107	216	8.5	309	12.2	12	0.5	150	5.9	300	11.8	129
BMS 60 -4 HP-A-C-P-A	98872109	254	10.0	379	14.9	15	0.6	175	6.9	350	13.8	183
BMS 60 -6 HP-A-C-P-A	98872110	254	10.0	379	14.9	15	0.6	175	6.9	350	13.8	216

Dimensional sketch

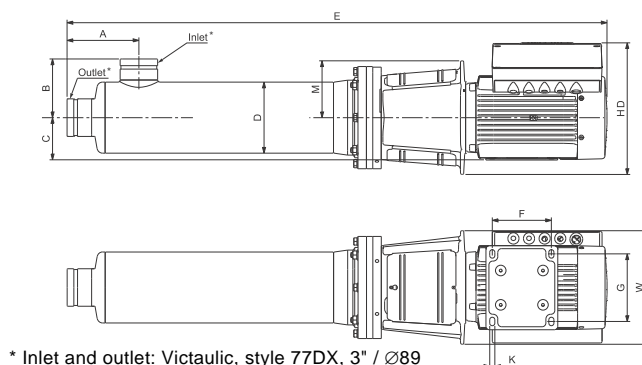

* Inlet and outlet: Victaulic, style 77DX, 3" / Ø89

Fig. 29 BMS hp booster system

TM06 0941 5114

BMS hp MG booster system 8"

BMS hp	Product number	Inlet/outlet horizontal [A]		Inlet/outlet vertical [B]		Centre height [C]		Sleeve diameter [D]		Total length [E]		Motor dimension [F]	
		[mm]	[inch]	[mm]	[inch]	[mm]	[inch]	[mm]	[inch]	[mm]	[inch]	[mm]	[inch]
BMS 77 -2A HP-A-C-P-A	98872111	275	10.8	206.5	8.1	160	6.3	273.0	10.7	1857	73.1	210	8.3
BMS 77 -3 HP-A-C-P-A	98872112	275	10.8	206.5	8.1	160	6.3	273.0	10.7	2029	79.9	254	10.0
BMS 95 -2 HP-A-C-P-A	98872113	275	10.8	206.5	8.1	160	6.3	273.0	10.7	1857	73.1	210	8.3
BMS 95 -3 HP-A-C-P-A	98872116	275	10.8	206.5	8.1	180	7.1	273.0	10.7	2055	80.9	241	9.5
BMS 125 -1 HP-A-C-P-A	98872117	275	10.8	206.5	8.1	160	6.3	273.0	10.7	1807	71.1	254	10.0
BMS 125 -2AA HP-A-C-P-A	98872119	275	10.8	206.5	8.1	180	7.1	273.0	10.7	1988	78.3	241	9.5
BMS 160 -1A HP-A-C-P-A	98872120	275	10.8	206.5	8.1	160	6.3	273.0	10.7	1763	69.4	210	8.3
BMS 160 -1 HP-A-C-P-A	98872121	275	10.8	206.5	8.1	180	7.1	273.0	10.7	1833	72.2	241	9.5
BMS 160 -2AA HP-A-C-P-A	98494526	275	10.8	206.5	8.1	200	7.9	273.0	10.7	2058	81.0	305	12.0
BMS 215 -1A HP-A-C-P-A	98494527	275	10.8	206.5	8.1	200	7.9	273.0	10.7	2041	80.4	305	12.0
BMS 215 -1 HP-A-C-P-A	98494528	275	10.8	206.5	8.1	200	7.9	273.0	10.7	2066	81.3	305	12.0

BMS hp	Product number	Motor dimension [G]		Motor dimension [HD]		Dimension [K]		Dimension [M]		Width [W]		Weight [kg]
		[mm]	[inch]	[mm]	[inch]	[mm]	[inch]	[mm]	[inch]	[mm]	[inch]	
BMS 77 -2A HP-A-C-P-A	98872111	254	10.0	379	14.9	15	0.6	175	6.9	350	13.8	225
BMS 77 -3 HP-A-C-P-A	98872112	254	10.0	379	14.9	15	0.6	175	6.9	350	13.8	256
BMS 95 -2 HP-A-C-P-A	98872113	254	10.0	379	14.9	15	0.6	175	6.9	350	13.8	234
BMS 95 -3 HP-A-C-P-A	98872116	279	11.0	384	15.1	15	0.6	175	6.9	350	13.8	270
BMS 125 -1 HP-A-C-P-A	98872117	254	10.0	379	14.9	15	0.6	175	6.9	350	13.8	255
BMS 125 -2AA HP-A-C-P-A	98872119	279	11.0	384	15.1	15	0.6	175	6.9	350	13.8	281
BMS 160 -1A HP-A-C-P-A	98872120	254	10.0	379	14.9	15	0.6	175	6.9	350	13.8	240
BMS 160 -1 HP-A-C-P-A	98872121	279	11.0	384	15.1	15	0.6	175	6.9	350	13.8	271
BMS 160 -2AA HP-A-C-P-A	98494526	318	12.5	515	20.3	19	0.7	200	7.9	400	15.7	392
BMS 215 -1A HP-A-C-P-A	98494527	318	12.5	515	20.3	19	0.7	200	7.9	400	15.7	391
BMS 215 -1 HP-A-C-P-A	98494528	318	12.5	515	20.3	19	0.7	200	7.9	400	15.7	416

Dimensional sketch

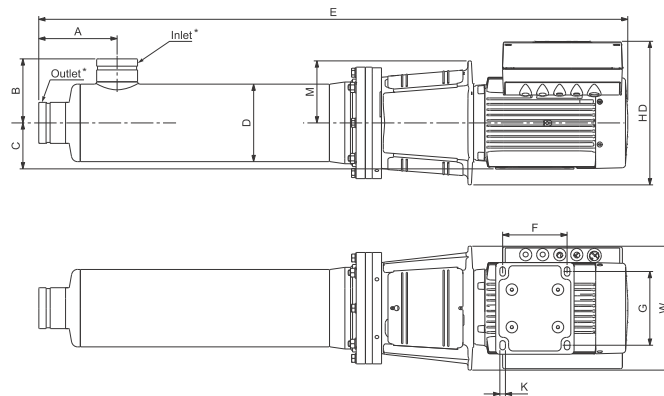

* Inlet and outlet: Victaulic, style 77DX, 6" / Ø168

Fig. 30 BMS hp booster system

TM06 0941 5114

BMS hp MGE booster system 6"

BMS hp	Product number	Inlet/outlet horizontal [A]		Inlet/outlet vertical [B]		Centre height [C]		Sleeve diameter [D]		Total length [E]		Motor dimension [F]	
		[mm]	[inch]	[mm]	[inch]	[mm]	[inch]	[mm]	[inch]	[mm]	[inch]	[mm]	[inch]
BMS 17-3 HP-C-C-P-A	98494496	170	6.7	139	5.5	100	3.9	168.3	6.6	1281	50.4	140	5.5
BMS 17-5 P-C-C-P-A	98494497	170	6.7	139	5.5	132	5.2	168.3	6.6	1458	57.4	140	5.5
BMS 17-7 HP-C-C-P-A	98494498	170	6.7	139	5.5	132	5.2	168.3	6.6	1567	61.7	140	5.5
BMS 30-3 HP-C-C-P-A	98494499	170	6.7	139	5.5	132	5.2	168.3	6.6	1432	56.4	140	5.5
BMS 30-5 HP-C-C-P-A	98494500	170	6.7	139	5.5	132	5.2	168.3	6.6	1624	63.9	140	5.5
BMS 30-7 HP-C-C-P-A	98494511	170	6.7	139	5.5	160	6.3	168.3	6.6	2018	79.4	210	8.3
BMS 46-2 HP-C-C-P-A	98494512	170	6.7	139	5.5	132	5.2	168.3	6.6	1382	54.4	140	5.5
BMS 46-4 HP-C-C-P-A	98494513	170	6.7	139	5.5	160	6.3	168.3	6.6	1798	70.8	210	8.3
BMS 46-6A HP-C-C-P-A	98494514	170	6.7	139	5.5	160	6.3	168.3	6.6	2024	79.7	210	8.3
BMS 60-2 HP-C-C-P-A	98494515	170	6.7	139	5.5	132	5.2	168.3	6.6	1370	53.9	140	5.5
BMS 60-4 HP-C-C-P-A	98494516	170	6.7	139	5.5	160	6.3	168.3	6.6	1798	70.8	210	8.3
BMS 60-6 HP-C-C-P-A	98494517	170	6.7	139	5.5	160	6.3	168.3	6.6	2068	81.4	254	10

BMS hp	Product number	Motor dimension [G]		Motor dimension [HD]		Dimension [K]		Dimension [M]		Width [W]		Weight [kg]
		[mm]	[inch]	[mm]	[inch]	[mm]	[inch]	[mm]	[inch]	[mm]	[inch]	
BMS 17-3 HP-C-C-P-A	98494496	160	6.3	312	12.2	12	0.5	135	5.3	270	10.6	101
BMS 17-5 P-C-C-P-A	98494497	216	8.5	338	13.3	12	0.5	150	5.9	300	11.8	103
BMS 17-7 HP-C-C-P-A	98494498	216	8.5	363	14.3	12	0.5	150	5.9	300	11.8	146
BMS 30-3 HP-C-C-P-A	98494499	216	8.5	338	13.3	12	0.5	150	5.9	300	11.8	127
BMS 30-5 HP-C-C-P-A	98494500	216	8.5	363	14.3	12	0.5	150	5.9	300	11.8	147
BMS 30-7 HP-C-C-P-A	98494511	254	10	483	19	15	0.6	175	6.7	420	16.5	220
BMS 46-2 HP-C-C-P-A	98494512	216	8.5	338	13.3	12	0.5	150	5.9	300	11.8	125
BMS 46-4 HP-C-C-P-A	98494513	254	10	483	19	15	0.6	175	6.7	420	16.5	214
BMS 46-6A HP-C-C-P-A	98494514	254	10	483	19	15	0.6	175	6.7	420	16.5	235
BMS 60-2 HP-C-C-P-A	98494515	216	8.5	363	14.3	12	0.5	150	5.9	300	11.8	139
BMS 60-4 HP-C-C-P-A	98494516	254	10	483	19	15	0.6	175	6.7	420	16.5	214
BMS 60-6 HP-C-C-P-A	98494517	254	10	483	19	15	0.6	175	6.7	420	16.5	248

Dimensional sketch

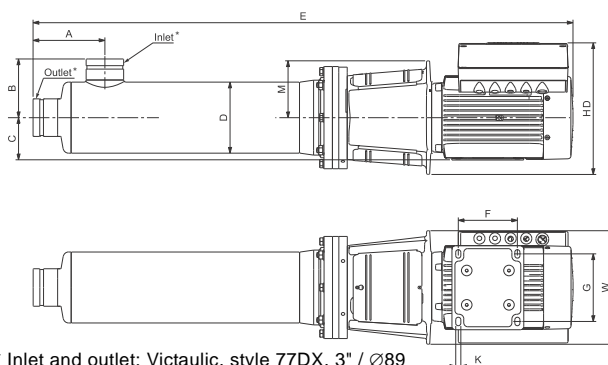

* Inlet and outlet: Victaulic, style 77DX, 3" / Ø89

Fig. 31 BMS hp booster system

TM06 09411 5114

BMS hp MGE booster system 8"

BMS hp	Product number	Inlet/outlet horizontal [A]		Inlet/outlet vertical [B]		Centre height [C]		Sleeve diameter [D]		Total length [E]		Motor dimension [F]	
		[mm]	[inch]	[mm]	[inch]	[mm]	[inch]	[mm]	[inch]	[mm]	[inch]	[mm]	[inch]
BMS 77 -2A HP-C-C-P-A	98494518	275	10.8	206.5	8.1	160	6.3	273	10.7	1852	72.9	210	8.3
BMS 77 -3 HP-C-C-P-A	98494519	275	10.8	206.5	8.1	160	6.3	273	10.7	2024	79.7	254	9.9
BMS 95 -2 HP-C-C-P-A	98494520	275	10.8	206.5	8.1	160	6.3	273	10.7	1852	72.9	210	8.3
BMS 95 -3 HP-C-C-P-A	98494521	275	10.8	206.5	8.1	180	7.1	273	10.7	2050	80.7	241	9.5
BMS 125 -1 HP-C-C-P-A	98494522	275	10.8	206.5	8.1	160	6.3	273	10.7	1802	70.9	254	9.9
BMS 125 -2AA HP-C-C-P-A	98494523	275	10.8	206.5	8.1	180	7.1	273	10.7	1983	78.1	241	9.5
BMS 160 -1A HP-C-C-P-A	98494524	275	10.8	206.5	8.1	160	6.3	273	10.7	1758	69.2	210	8.3
BMS 160 -1 HP-C-C-P-A	98494525	275	10.8	206.5	8.1	180	7.1	273	10.7	1828	72.0	241	9.5

BMS hp	Product number	Motor dimension [G]		Motor dimension [HD]		Dimension [K]		Dimension [M]		Width [W]		Weight [kg]
		[mm]	[inch]	[mm]	[inch]	[mm]	[inch]	[mm]	[inch]	[mm]	[inch]	
BMS 77 -2A HP-C-C-P-A	98494518	254	9.9	483	19	15	0.6	175	6.9	420	16.5	255
BMS 77 -3 HP-C-C-P-A	98494519	254	9.9	483	19	15	0.6	175	6.9	420	16.5	288
BMS 95 -2 HP-C-C-P-A	98494520	254	9.9	483	19	15	0.6	175	6.9	420	16.5	267
BMS 95 -3 HP-C-C-P-A	98494521	279	11.0	488	19.2	15	0.6	175	6.9	420	16.5	302
BMS 125 -1 HP-C-C-P-A	98494522	254	9.9	483	19	15	0.6	175	6.9	420	16.5	287
BMS 125 -2AA HP-C-C-P-A	98494523	279	11.0	488	19.2	15	0.6	175	6.9	420	16.5	314
BMS 160 -1A HP-C-C-P-A	98494524	254	9.9	483	19	15	0.6	175	6.9	420	16.5	274
BMS 160 -1 HP-C-C-P-A	98494525	279	11.0	488	19.2	15	0.6	175	6.9	420	16.5	303

Dimensional sketch

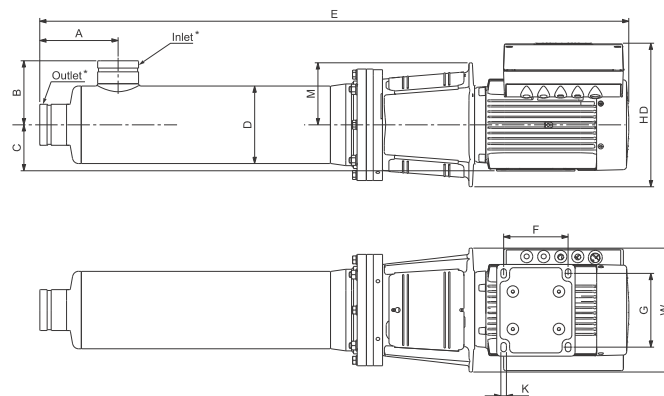

* Inlet and outlet: Victaulic, style 77DX, 6" / Ø168

Fig. 32 BMS hp booster system

TM06 09411 5114

12. Technical data

Material specification for BMS hs and BMS hp pump

Pos.	Component	Materials	R-version		
			DIN	AISI	PREN
1	Top chamber	Stainless steel	1.4539	904L	34
2	Top bearing	Stainless steel/NBR	1.4539	904L	34
3	Bearing				
4	Neck ring	NBR/PPS	-	-	-
5	Intermediate bearing	NBR	-	-	-
6	Spacing washer for stop ring	Carbon/graphite, PTFE	-	904L	34
8	Chamber	Stainless steel	1.4539	904L	34
10	Nut for split cone	Stainless steel	1.4539	904L	34
12	Split cone	Stainless steel	1.4539	904L	34
13	Impeller	Stainless steel	1.4539	904L	34
14	Inlet interconnector	Stainless steel	1.4539	904L	34
16	Shaft	Stainless steel	1.4462	SAF 2205	34
17	Strap	Stainless steel	1.4539	904L	34
18	Nut for strap	Stainless steel	1.4539	904L	34
19	Coupling	Stainless steel	1.4462	SAF 2205	34
20	Wear ring	Stainless steel	1.4539	904L	34
21	Check valve*	Stainless steel	1.4539	904L	34
22	Sleeve	Stainless steel	1.4462	SAF 2205	34
23	Inlet	Super duplex stainless steel**	1.4410	SAF 2507	43
24	Outlet	Super duplex stainless steel**	1.4410	SAF 2507	43

* Optional for BMS hp

**The super duplex material is used in areas with stagnant water to reduce the risk of crevice corrosion.

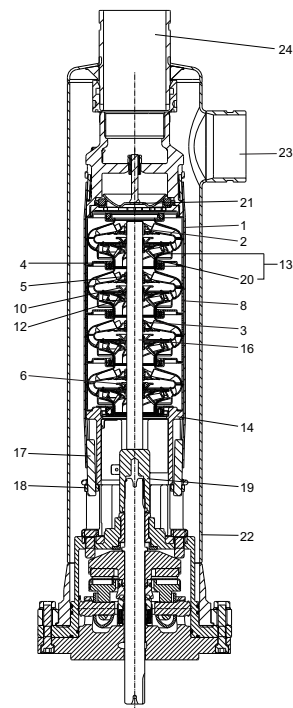
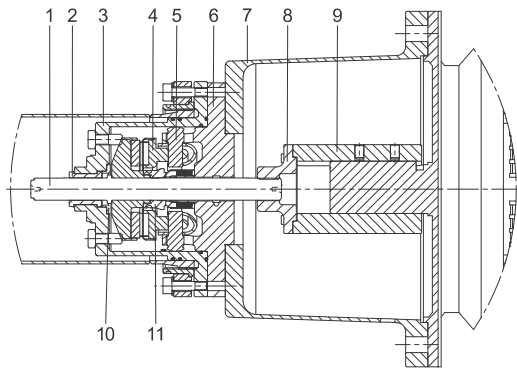

Fig. 33 BMS hp

TM06 1190 1814

Material specification for thrust-bearing housing



TM05 9437 3813

Fig. 34 Sectional drawing for BMS hs

Pos.	Component	Materials*	R-version		
			DIN	AISI	PREN
1	Shaft with thrust bearing for BMS	Stainless steel/ceramic	1.4462/1.4539	SAF 2205/904L	34
2	Bearing	NBR	-	-	-
3	Housing for thrust bearing	Super Duplex stainless steel*	1.4410	SAF 2507	43
4	Thrust bearing CPL	Stainless steel/carbon	1.4547/1.4462/1.4539	254SMO/SAF 2205/904L	43/34/34
5	Pin	Super Duplex stainless steel*	1.4410	SAF 2507	43
6	Housing for shaft seal	Super Duplex stainless steel*	1.4410	SAF 2507	43
7	Housing for bell, GG-RV	Cast iron GG25	0.6025	-	-
8	Coupling spline for BMS	Impax Supreme	-	-	-
9	Shaft bushing D55	CK45	CK45	1045	-
10	Axial bearing	Acoflon 214G	-	-	-
11	Shaft seal Roten SGR5	Ceramic/silicon carbide	-	-	-

* The super duplex material is used in areas with stagnant water to reduce the risk of crevice corrosion.

13. Accessories

CUE frequency converter

Grundfos CUE is a series of external frequency converters designed for speed control of a wide range of Grundfos pumps.

When CUE is installed, the motor requires no further motor protection.

CUE offers quick and easy setup and commissioning compared to a standard frequency converter because of the startup guide. Simply key in application-specific variables such as motor data, pump family, control function (e.g. constant pressure), sensor type, and setpoint, and CUE will automatically set all necessary parameters.

CUE enables gentle pumping and thereby protects the water reservoir and the rest of the distribution system, as water hammer can be avoided by adjusting ramp times up and down.

Overview of the CUE range

Supply voltage [V]	Power range [kW]						
	0.55	0.75	1.1	7.5	11	45	250
3 x 525-690							
3 x 525-600							
3 x 380-500							
3 x 200-240							
1 x 200-240							

CUE is available in two enclosure classes:

- IP20/21
- IP54/55.

Note: The maximum CUE frequency is 120 Hz.

RFI filters

To meet the EMC requirements, CUE comes with the following types of built-in radio frequency interference filter (RFI).

Voltage [V]	Typical shaft power, P2 [kW]	RFI filter type	Application
1 x 200-240	1.1 - 7.5	C1	
3 x 200-240	0.75 - 45	C1	Domestic
	0.55 - 90	C1	
3 x 380-500	110-250	C2	Domestic/industry
3 x 525-600	0.75 - 7.5	C3	Industry
3 x 525-690	11-25	C3	



GrA4404

Fig. 35 The CUE range

Functions

CUE has a wide range of pump-specific functions, such as

- constant pressure
- constant level
- constant flow rate
- constant temperature
- constant curve.

CUE features

- Startup guide
CUE incorporates an innovative startup guide for the general setting of CUE including the setting of the correct direction of rotation. The startup guide is started the first time when CUE is connected to the power supply.
- Check of direction of rotation.
- Duty/standby operation.
- Dry-running protection.
- Low-flow stop function.

Inputs and outputs

CUE incorporates various inputs and outputs:

- one RS-485 GENIbus connection
- one analog input, 0-10 V, 0/4-20 mA
 - external setpoint
- one analog input, 0/4-20 mA
 - sensor input, feedback sensor
- one analog output, 0-20 mA
- four digital inputs
 - start/stop and three programmable inputs
- two signal relays (C/NO/NC)
 - programmable.

Accessories for CUE

Grundfos offers various accessories for CUE.

MCB 114 sensor input module

MCB 114 offers additional analog inputs for CUE:

- one analog input, 0/4-20 mA
- two inputs for Pt100 and Pt1000 temperature sensors.

Output filters

Output filters are used primarily to protect the motor against overvoltage and increased operating temperature. However, you can also use output filters to reduce acoustic noise from the motor.

Grundfos offers two types of output filter as accessories for CUE:

- dU/dt filters
- sine-wave filters.

Floor-mounting option

CUE is as standard installed on the wall. You can also install the enclosures D1 and D2 on the floor on a pedestal designed for that purpose.

For information about enclosures, see the product-specific documentation for CUE.

IP21/NEMA1 option

You can upgrade an IP20 enclosure to IP21/NEMA1 by using the IP21/NEMA1 option. The power terminals (mains and motor) will be covered.

Sensors

You can use the following sensors in connection with CUE. All sensors are with 4-20 mA output signal:

- pressure sensors, up to 25 bar
- temperature sensors
- differential-pressure sensors
- differential-temperature sensors
- flowmeters
- potentiometer box for external setpoint setting.

Gateways

CUE has a standard RS-485 GENIbus interface. Gateways to convert to other bus standards are available as accessories.

The CIU family (CIU = Communication Interface Units) can convert from GENIbus to the most common fieldbuses in the world:

- CIU 100 converts from GENIbus to LonWorks.
- CIU 150 converts from GENIbus to Profibus DP.
- CIU 200 converts from GENIbus to Modbus RTU.
- CIU 250 is a GSM modem which can send SMS messages in case of alarms, etc.

Control MPC

Control MPC, a multipump control system for the control of parallel-connected CUE pump solutions.

Use of output filters

The table below shows in which cases an output filter is required. From the table, you can see if a filter is required, and which type to use.

The selection depends on these factors:

- pump type
- motor cable length
- the required reduction of acoustic noise from the motor.

Pump type	Typical shaft power P2	dU/dt filter	Sine-wave filter
SP with 380 V motor and up	Up to 7.5 kW	-	0-300 m
	11 kW and up	0-150 m	150-300 m

The lengths stated apply to the motor cable.

Cables used in CUE installations

Note: When CUE is installed in connection with SP pumps, we distinguish between two types of installation:

- installation in EMC-insensitive sites. See fig. 36.
- installation in EMC-sensitive sites. See fig. 37.

The two types of installation are different when it comes to the use of screened cable.

Note: Drop cables are always unscreened.

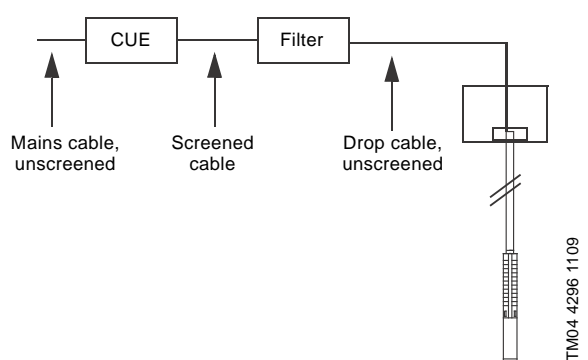

Fig. 36 Example of installation in EMC-insensitive sites

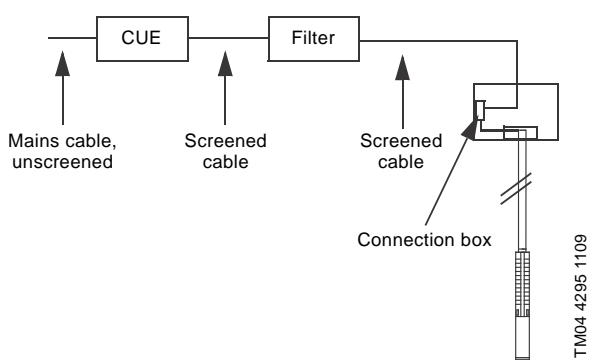

Fig. 37 Example of installation in EMC-sensitive sites



Screened cables are required in those parts of the installation where the surroundings must be protected against EMC.

CUE is the right choice of frequency converter in SP installations as it meets all basic issues. CUE has a pre-installed startup guide that takes the installer through all the necessary settings.

The table below shows the different issues to be considered when using frequency converters in SP installations.

Issues to be considered	Explanation
Ramp (up and down): Maximum 3 seconds.	Lubricate the journal bearings in order to limit wear and overheating of windings.
Use temperature monitoring by Pt sensor.	Overheating of the motor => low insulation resistance => sensitive to voltage peaks.
Reduce peak voltages (maximum 800 V peaks).	Never exceed peak voltages of 850 V at motor leads.
For MS and MMS, we recommend that you use motors with 10 % extra in given duty point. For MMS, always use motors (PE2-PA-wound).	CUE with output filter is a safe solution.
Remember output filter.	Cables act as an amplifier => measure peaks at the motor.
Limit the rise time (dU/dt) to a maximum of 1000 V/μs. Determined by the equipment in CUE.	Time between switches is an expression of losses, so in the future, we might have to exceed the limit of 1000 V/μs. The solution is not higher insulation of the motor, but filter in the output from CUE.
Minimum 30 Hz. Use a 60 Hz motor for larger range.	Too low speed => no lubrication of journal bearings.
Size the CUE in respect of the current, not the power output.	Can end up with a too small CUE.
Size cooling provision for stator tube at duty point with lowest flow rate.	Consider a flow minimum along the stator housing.
Ensure that the pump is used within the range of the pump curve.	Focus on the outlet pressure and sufficient NPSH, as vibrations will damage the motor.

BMS hp

Parts	Description	Specification	Product number
	TM00 3712 0894 Victaulic coupling in stainless steel 3": Ø89 4": Ø114 5": Ø139 6": Ø168	NBR seal 3", style 77DX	97758517
		NBR seal 4", style 77DX	97758346
		NBR seal 5", style 489	97758342
		NBR seal 6", style 77DX	97758320
	TM00 3709 0894 Victaulic coupling liner for welding	R-version 3"	00140968
		R-version 4"	96986570
		R-version 5"	96785838
		R-version 6"	96230662

Customised BMS pumps

We offer customised variants of the BMS type for a variety of applications.

Please contact your local Grundfos supplier.

14. Grundfos Product Center

Online search and sizing tool to help you make the right choice.

<http://product-selection.grundfos.com>



SIZING enables you to size a pump based on entered data and selection choices.

REPLACEMENT enables you to find a replacement product. Search results will include information on

- the lowest purchase price
- the lowest energy consumption
- the lowest total life cycle cost.

The screenshot shows the Grundfos Product Center website. At the top, there is a navigation bar with the logo and 'PRODUCT CENTER'. Below it, a menu includes 'HOME', 'FIND PRODUCT', 'COMPARE', 'YOUR PROJECTS', 'SAVED ITEMS', and 'HELP'. A search bar is prominently displayed with the text 'Input a product number or a whole or partial product name'. Below the search bar are four main navigation buttons: 'SIZING' (with a subtext 'Enter pump sizing'), 'CATALOGUE' (with a subtext 'Products and services'), 'REPLACEMENT' (with a subtext 'Replace an old pump with a new'), and 'LIQUIDS' (with a subtext 'Find pump by liquid'). The 'QUICK SIZING' section is visible, featuring input fields for 'Flow (Q)*' (m³/h) and 'Head (H)*' (m), and radio buttons for 'Select what to size by': 'Size by application', 'Size by pump design', and 'Size by pump family'. A 'START SIZING' button is located to the right of these options. At the bottom of the 'QUICK SIZING' section, there are links for 'ADVANCED SIZING' with sub-options for 'Advanced sizing by application' and 'Guided selection'.

CATALOGUE gives you access to the Grundfos product catalogue.

LIQUIDS enables you to find pumps designed for aggressive, flammable or other special liquids.

All the information you need in one place

Performance curves, technical specifications, pictures, dimensional drawings, motor curves, wiring diagrams, spare parts, service kits, 3D drawings, documents, system parts. The Product Center displays any recent and saved items - including complete projects - right on the main page.

Downloads

On the product pages, you can download installation and operating instructions, data booklets, service instructions, etc. in PDF format.

Subject to alterations.

98567333 0316

ECM: 1180323

GRUNDFOS A/S
DK-8850 Bjerringbro . Denmark
Telephone: +45 87 50 14 00
www.grundfos.com

GRUNDFOS 