



water solutions



ZM series

ZMD
ZMR

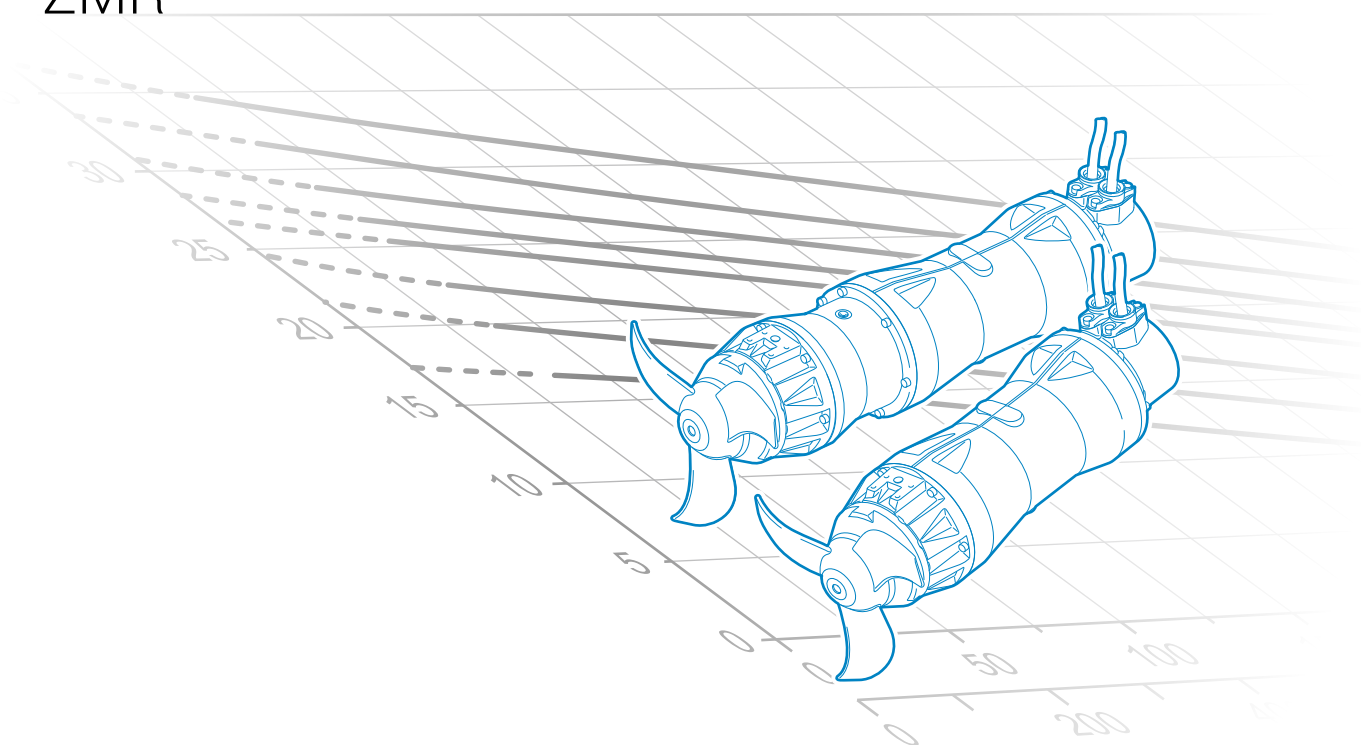

D A T A B O O K L E T



water solutions

ZM Series

ZMD

ZMR



D A T A B O O K L E T

ZM Series

General characteristics



- Innovative cable gland system with cable holder. The universal thread ring-nut can be removed to fix a rigid or flexible duct to the cable gland to protect the cable from physical and mechanical stresses.
- Premium IE3 class cold-running motor for high efficiency and minimal energy use. Isolation class H (180°C).
- Some versions are suitable for 60°C max ambient temperature (on request)
- Two silicon carbide (SiC) mechanical seals protected inside a large, inspectable oil chamber. ZMR models equipped with 3 mechanical seals.
- Cast AISI 316 stainless steel propeller, designed with specially shaped blades to ensure high hydraulic efficiency and prevent fouling with filaments and solids. Extra thick for ruggedness and reliability even in heavy-duty conditions.
- Ball bearings with lifetime lubrication designed to guarantee 100,000 working hours. Temperature sensor on request.
- Rugged planetary reduction gearbox which provides high reduction ratios and torque transfer and withstands heavy radial loads, with compact size and light weight.
- Water sensor detecting seepage into the mechanical seal oil chamber. The temperature sensors prevent possible damage due to overheating of the motor and bearings (other monitoring options are available for the ZMR 065 and ZMR 090 models on request)
- Wide range of rugged stainless steel accessories for optimal installation in relation to the system layout and when replacing existing devices.

Available series



ZMD Series

page 5

- 4 - 6 - 8 poles motor with DIRECT TRANSMISSION
- Motor power 0.75 ÷ 4.5 kW
- Propeller Ø 200 - 300 - 400 mm



ZMR Series

page 20

- 4 poles motor with REDUCTION GEARS
- Motor power 4 ÷ 18.5 kW
- Propeller Ø 650 -900 mm

Key to product code

ZM D 030C A 1.5/6 A F 010

① ② ③ ④ ⑤ ⑥ ⑦ ⑧ ⑨

- | | |
|--|--|
| ① Designation | ⑤ Motor power (kW) |
| ② Transmission type
D = Direct
R = With reduction gear | ⑥ Poles |
| ③ Type of propeller | ⑦ Motor efficiency and version |
| ④ Flow ring version | ⑧ Dimensions of electromechanical assembly |
| | ⑨ Reduction ratio |

All data made available remain non-binding. Product images are indicative. Zenit reserves the right to make unannounced product changes it deems appropriate.

ZMD 020A A 0.75/4 HA 010

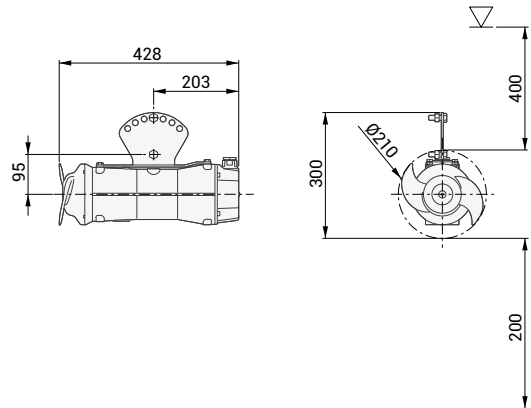

23 Kg (stand and guiding system excluded)

Product

Type	MIXER
Name	ZMD 020A A 0.75/4 HA 010
Configured	-
Standard	CE
ATEX marking	-

Motor

Rated Voltage	400 V
Frequency	50 Hz
Motor phases	3
Number of poles	4
Incoming power P2	0.75 kW
Electric power P1	1.0kW
Rated current	2.0 A
rpm	1396 rpm
Efficiency	76%
Cos φ	0.719
Rated torque	5.1 Nm
Start	DOL
Starting current	8.7 A
Starting torque	11.9 Nm
Degree of protection	IP 68
Insulation class	H
Motor efficiency class ref.	

Gear unit

Type	-
Gear ratio	1

Propeller

Name	020A
Rated diameter	200 mm
Number of blades	2
rpm	1396 rpm
Pp2	0.48 kW
Propeller thrust	155 N
Jet ring	-

Cable

Type	4G1.5
Length	10 m

Monitoring

Thermal protector	-
Leakage sensor	-

Operating limits

Ambient temperature	0 ÷ 40°C
Max. density treated liquid	1100 Kg/m ³
pH treated liquid	6-14
Max. start per hour	20 /h (equally distributed)
Max. acoustic pressure level	Max 70 dB (A)
Operating mode	S1 – Continuous use

Construction materials

Case	Cast iron EN-GJL-250
Gear box	-
Propeller	AISI 316 (optional AISI 329)
Jet ring	-
Shaft	AISI 431
Mechanical seal (motor side)	Silicon carbide
Mechanical seal (propeller side)	Silicon carbide
Painting	Bi-epoxy 200 μm (optional 400 μm)
Screws	Stainless steel A2-70 (optional A4)
Gaskets	NBR
Fixing system	AISI 304 stainless steel (optional AISI 316)

Installation

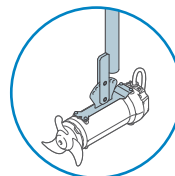

STANDARD

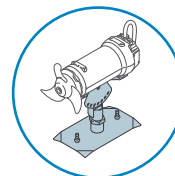

OPTIONAL

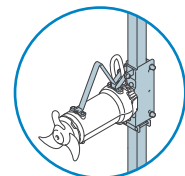

OPTIONAL

50 x 50
60 x 60
80 x 80

ZMD

ZMD 020B A 1.1/4 HA 010

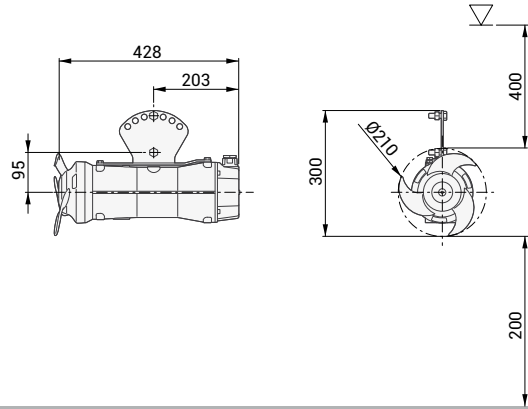

kg 23 Kg (stand and guiding system excluded)

Product

Type	MIXER
Name	ZMD 020B A 1.1/4 HA 010
Configured	-
Standard	CE
ATEX marking	-

Motor

Rated Voltage	400 V
Frequency	50 Hz
Motor phases	3
Number of poles	4
Incoming power P2	1.1 kW
Electric power P1	1.5 kW
Rated current	3.0 A
rpm	1380 rpm
Efficiency	75.0%
Cos φ	0.701
Rated torque	7.6 Nm
Start	DOL
Starting current	12.4 A
Starting torque	17.8 Nm
Degree of protection	IP 68
Insulation class	H

Gear unit

Type	-
Gear ratio	1

Propeller

Name	020B
Rated diameter	200 mm
Number of blades	3
rpm	1380 rpm
Pp2	0.95 kW
Propeller thrust	210 N
Jet ring	-

Cable

Type	4G1.5
Length	10 m

Monitoring

Thermal protector	-
Leakage sensor	-

Operating limits

Ambient temperature	0 ÷ 40°C
Max. density treated liquid	1100 Kg/m ³
pH treated liquid	6-14
Max. start per hour	20 /h (equally distributed)
Max. acoustic pressure level	Max 70 dB (A)
Operating mode	S1 – Continuous use

Construction materials

Case	Cast iron EN-GJL-250
Gear box	-
Propeller	AISI 316 (optional AISI 329)
Jet ring	-
Shaft	AISI 431
Mechanical seal (motor side)	Silicon carbide
Mechanical seal (propeller side)	Silicon carbide
Painting	Bi-epoxy 200 µm (optional 400 µm)
Screws	Stainless steel A2-70 (optional A4)
Gaskets	NBR
Fixing system	AISI 304 stainless steel (optional AISI 316)

Installation

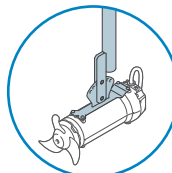

STANDARD

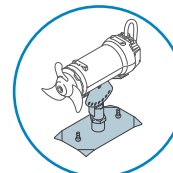

OPTIONAL

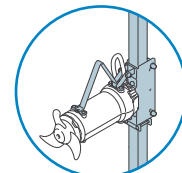

OPTIONAL

50 x 50
60 x 60
80 x 80

ZMD 020A A 0.75/4 AE 010

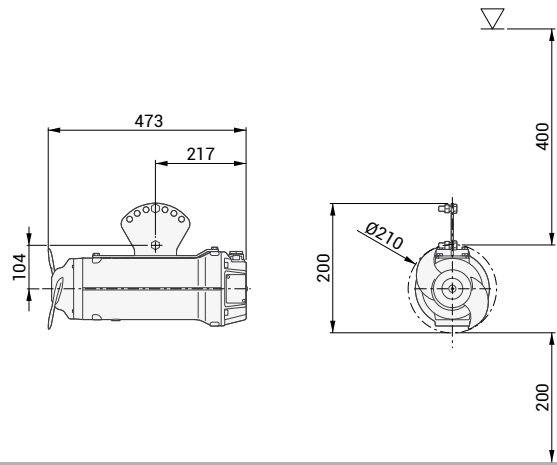

kg 35 Kg (stand and guiding system excluded)

Product

Type	MIXER
Name	ZMD 020A A 0.75/4 AE 010
Configured	-
Standard	CE
ATEX marking	Optional (from DECEMBER 2019)

Motor

Rated Voltage	400 V
Frequency	50 Hz
Motor phases	3
Number of poles	4
Incoming power P2	0.75 kW
Electric power P1	0.9 kW
Rated current	1.8 A
rpm	1444 rpm
Efficiency	82.5 %
Cos φ	0.729
Rated torque	5.0 Nm
Start	DOL
Starting current	11.2 A
Starting torque	12.1 Nm
Degree of protection	IP 68
Insulation class	H
Motor efficiency class ref.	IE3

Gear unit

Type	-
Gear ratio	1

Propeller

Name	020A
Rated diameter	200 mm
Number of blades	2
rpm	1444 rpm
Pp2	0.51 kW
Propeller thrust	165 N
Jet ring	Optional

Cable

Type	4G1.5 + 3x1
Length	10 m

Monitoring

Thermal protector	klixon
Leakage sensor	1 in mechanical seals chamber

Operating limits

Ambient temperature	0 ÷ 60°C
Max. density treated liquid	1100 Kg/m ³
pH treated liquid	6-14
Max. start per hour	20 /h (equally distributed)
Max. acoustic pressure level	Max 70 dB (A)
Operating mode	S1 – Continuous use

Construction materials

Case	Cast iron EN-GJL-250
Gear box	-
Propeller	AISI 316 (optional AISI 329)
Jet ring	-
Shaft	AISI 431
Mechanical seal (motor side)	Silicon carbide
Mechanical seal (propeller side)	Silicon carbide
Painting	Bi-epoxy 200 µm (optional 400 µm)
Screws	Stainless steel A2-70 (optional A4)
Gaskets	NBR
Fixing system	AISI 304 stainless steel (optional AISI 316)

Installation

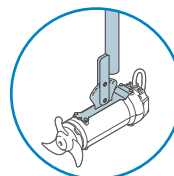

STANDARD

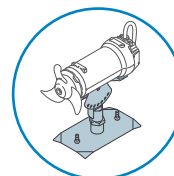

OPTIONAL

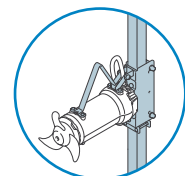

OPTIONAL

50 x 50
60 x 60
80 x 80

ZMD

ZMD 020B A 1.1/4 AE 010

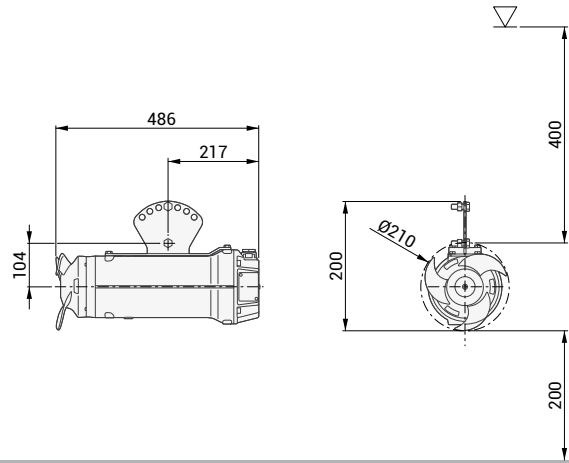

kg 35 Kg (stand and guiding system excluded)

Product

Type	MIXER
Name	ZMD 020B A 1.1/4 AE 010
Configured Standard	-
ATEX marking	CE Optional (from DECEMBER 2019)

Motor

Rated Voltage	400 V
Frequency	50 Hz
Motor phases	3
Number of poles	4
Incoming power P2	1.1 kW
Electric power P1	1.3 kW
Rated current	2.7 A
rpm	1436 rpm
Efficiency	84.1%
Cos φ	0.710
Rated torque	7.3 Nm
Start	DOL
Starting current	15.7 A
Starting torque	21.3 Nm
Degree of protection	IP 68
Insulation class	H
Motor efficiency class ref.	IE3

Gear unit

Type	-
Gear ratio	1

Propeller

Name	020B
Rated diameter	200 mm
Number of blades	3
rpm	1436 rpm
Pp2	0.98 kW
Propeller thrust	220 N
Jet ring	Optional

Cable

Type	4G1.5 + 3x1
Length	10 m

Monitoring

Thermal protector	klixon
Leakage sensor	1 in mechanical seals chamber

Operating limits

Ambient temperature	0 ÷ 60°C
Max. density treated liquid	1100 Kg/m ³
pH treated liquid	6-14
Max. start per hour	20 /h (equally distributed)
Max. acoustic pressure level	Max 70 dB (A)
Operating mode	S1 – Continuous use

Construction materials

Case	Cast iron EN-GJL-250
Gear box	-
Propeller	AISI 316 (optional AISI 329)
Jet ring	-
Shaft	AISI 431
Mechanical seal (motor side)	Silicon carbide
Mechanical seal (propeller side)	Silicon carbide
Painting	Bi-epoxy 200 µm (optional 400 µm)
Screws	Stainless steel A2-70 (optional A4)
Gaskets	NBR
Fixing system	AISI 304 stainless steel (optional AISI 316)

Installation

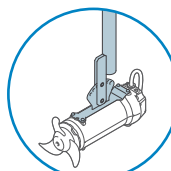

STANDARD

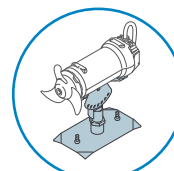

OPTIONAL

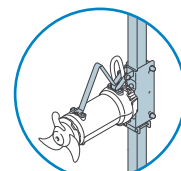

OPTIONAL

50 x 50
60 x 60
80 x 80

ZMD 020C A 1.5/4 AE 010

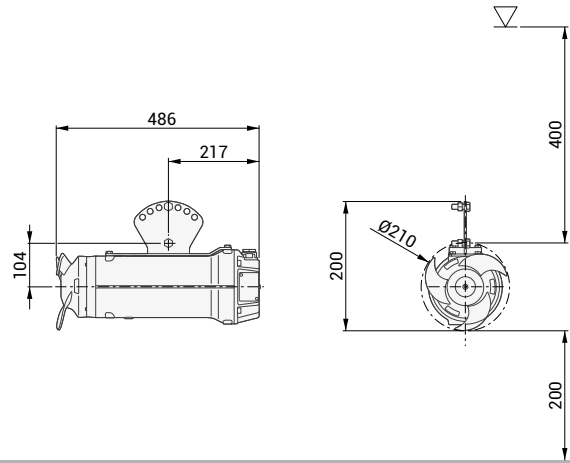

36 Kg (stand and guiding system excluded)

Product

Type	MIXER
Name	ZMD 020C A 1.5/4 AE 010
Configured Standard	-
ATEX marking	CE Optional (from DECEMBER 2019)

Motor

Rated Voltage	400 V
Frequency	50 Hz
Motor phases	3
Number of poles	4
Incoming power P2	1.5 kW
Electric power P1	1.8 kW
Rated current	3.6 A
rpm	1432 rpm
Efficiency	85.3%
Cos φ	0.703
Rated torque	10.0 Nm
Start	DOL
Starting current	20.3 A
Starting torque	26.2 Nm
Degree of protection	IP 68
Insulation class	H
Motor efficiency class ref.	IE3

Gear unit

Type	-
Gear ratio	1

Propeller

Name	020C
Rated diameter	200 mm
Number of blades	3
rpm	1432 rpm
Pp2	1.0 kW
Propeller thrust	230 N
Jet ring	Optional

Cable

Type	4G1.5 + 3x1
Length	10 m

Monitoring

Thermal protector	klixon
Leakage sensor	1 in mechanical seals chamber

Operating limits

Ambient temperature	0 ÷ 60°C
Max. density treated liquid	1100 Kg/m ³
pH treated liquid	6-14
Max. start per hour	20 /h (equally distributed)
Max. acoustic pressure level	Max 70 dB (A)
Operating mode	S1 – Continuous use

Construction materials

Case	Cast iron EN-GJL-250
Gear box	-
Propeller	AISI 316 (optional AISI 329)
Jet ring	-
Shaft	AISI 431
Mechanical seal (motor side)	Silicon carbide
Mechanical seal (propeller side)	Silicon carbide
Painting	Bi-epoxy 200 µm (optional 400 µm)
Screws	Stainless steel A2-70 (optional A4)
Gaskets	NBR
Fixing system	AISI 304 stainless steel (optional AISI 316)

Installation

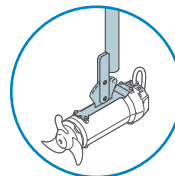

STANDARD

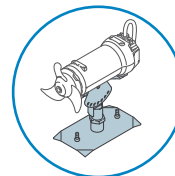

OPTIONAL

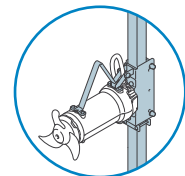

OPTIONAL

50 x 50
60 x 60
80 x 80

ZMD

ZMD 030C A 1.5/6 AF 010

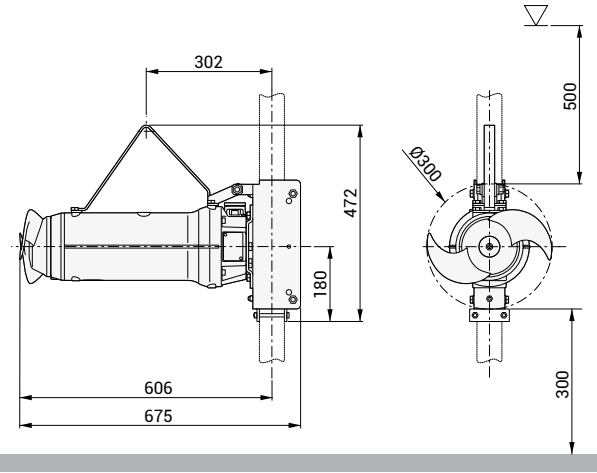

48 Kg (stand and guiding system excluded)

Product

Type	MIXER
Name	ZMD 030C A 1.5/6 AF 010
Configured Standard	-
ATEX marking	CE Optional (from DECEMBER 2019)

Motor

Rated Voltage	400 V
Frequency	50 Hz
Motor phases	3
Number of poles	6
Incoming power P2	1.5 kW
Electric power P1	1.8 kW
Rated current	3.7 A
rpm	942 rpm
Efficiency	82.5%
Cos φ	0.703
Rated torque	15.2 Nm
Start	DOL
Starting current	18.9 A
Starting torque	32.5 Nm
Degree of protection	IP 68
Insulation class	H
Motor efficiency class ref.	IE3

Gear unit

Type	-
Gear ratio	1

Propeller

Name	030C
Rated diameter	300 mm
Number of blades	2
rpm	942 rpm
Pp2	0.92 kW
Propeller thrust	350 N
Jet ring	Optional

Cable

Type	4G1.5 + 3x1
Length	10 m

Monitoring

Thermal protector	klixon
Leakage sensor	1 in mechanical seals chamber

Operating limits

Ambient temperature	0 ÷ 40°C
Max. density treated liquid	1100 Kg/m ³
pH treated liquid	6-14
Max. start per hour	20 /h (equally distributed)
Max. acoustic pressure level	Max 70 dB (A)
Operating mode	S1 – Continuous use

Construction materials

Case	Cast iron EN-GJL-250
Gear box	-
Propeller	AISI 316 (optional AISI 329)
Jet ring	-
Shaft	AISI 431
Mechanical seal (motor side)	Silicon carbide
Mechanical seal (propeller side)	Silicon carbide
Painting	Bi-epoxy 200 μm (optional 400 μm)
Screws	Stainless steel A2-70 (optional A4)
Gaskets	NBR
Fixing system	AISI 304 stainless steel (optional AISI 316)

Installation

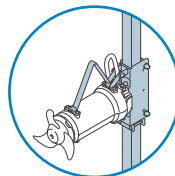

STANDARD

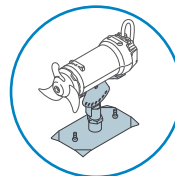

OPTIONAL

	standard 60 x 60
	optional 50 x 50
	80 x 80
	100 x 100

ZMD 030A A 1.5/6 AF 010

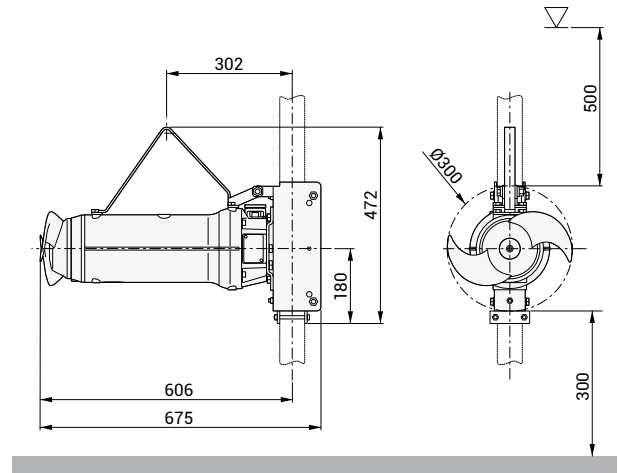

48 Kg (stand and guiding system excluded)

Product

Type	MIXER
Name	ZMD 030A A 1.5/6 AF 010
Configured Standard	-
ATEX marking	CE

Motor

Rated Voltage	400 V
Frequency	50 Hz
Motor phases	3
Number of poles	6
Incoming power P2	1.5 kW
Electric power P1	1.8 kW
Rated current	3.7 A
rpm	942 rpm
Efficiency	82.5%
Cos φ	0.703
Rated torque	15.2 Nm
Start	DOL
Starting current	18.9 A
Starting torque	32.5 Nm
Degree of protection	IP 68
Insulation class	H
Motor efficiency class ref.	IE3

Gear unit

Type	-
Gear ratio	1

Propeller

Name	030A
Rated diameter	300 mm
Number of blades	2
rpm	942 rpm
Pp2	1.33 kW
Propeller thrust	450 N
Jet ring	Optional

Cable

Type	4G1.5 + 3x1
Length	10 m

Monitoring

Thermal protector	klixon
Leakage sensor	1 in mechanical seals chamber

Operating limits

Ambient temperature	0 ÷ 60°C
Max. density treated liquid	1100 Kg/m ³
pH treated liquid	6-14
Max. start per hour	20 /h (equally distributed)
Max. acoustic pressure level	Max 70 dB (A)
Operating mode	S1 – Continuous use

Construction materials

Case	Cast iron EN-GJL-250
Gear box	-
Propeller	AISI 316 (optional AISI 329)
Jet ring	-
Shaft	AISI 431
Mechanical seal (motor side)	Silicon carbide
Mechanical seal (propeller side)	Silicon carbide
Painting	Bi-epoxy 200 μm (optional 400 μm)
Screws	Stainless steel A2-70 (optional A4)
Gaskets	NBR
Fixing system	AISI 304 stainless steel (optional AISI 316)

Installation

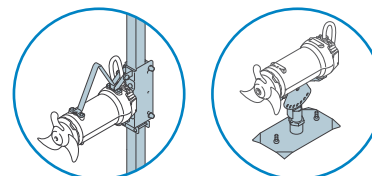

STANDARD
 standard 60 x 60
 optional 50 x 50
 80 x 80
 100 x 100

ZMD

ZMD 030B A 2.2/6 AF 010

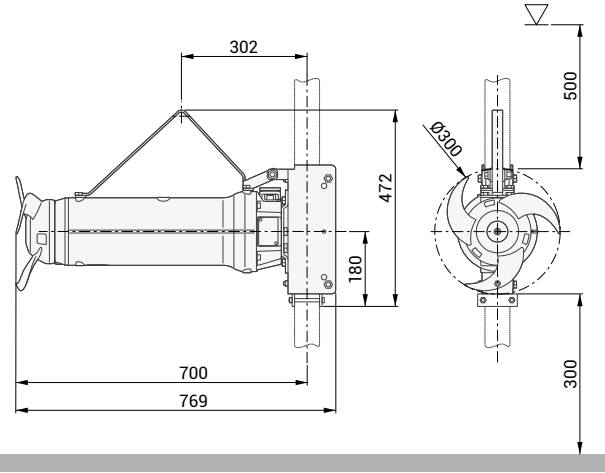

57 Kg (stand and guiding system excluded)

Product

Type	MIXER
Name	ZMD 030B A 2.2/6 AF 010
Configured Standard	-
ATEX marking	CE
	Optional (from DECEMBER 2019)

Motor

Rated Voltage	400 V
Frequency	50 Hz
Motor phases	3
Number of poles	6
Incoming power P2	2.2 kW
Electric power P1	2.6 kW
Rated current	5.5 A
rpm	942 rpm
Efficiency	84.3%
Cos φ	0.685
Rated torque	22.3 Nm
Start	DOL
Starting current	29.6 A
Starting torque	47.6 Nm
Degree of protection	IP 68
Insulation class	H
Motor efficiency class ref.	IE3

Gear unit

Type	-
Gear ratio	1

Propeller

Name	030B
Rated diameter	300 mm
Number of blades	3
rpm	942 rpm
Pp2	1.62 kW
Propeller thrust	500 N
Jet ring	Optional

Cable

Type	4G1.5 + 3x1
Length	10 m

Monitoring

Thermal protector	klixon
Leakage sensor	1 in mechanical seals chamber

Operating limits

Ambient temperature	0 ÷ 60°C
Max. density treated liquid	1100 Kg/m³
pH treated liquid	6-14
Max. start per hour	20 /h (equally distributed)
Max. acoustic pressure level	Max 70 dB (A)
Operating mode	S1 – Continuous use

Construction materials

Case	Cast iron EN-GJL-250
Gear box	-
Propeller	AISI 316 (optional AISI 329)
Jet ring	-
Shaft	AISI 431
Mechanical seal (motor side)	Silicon carbide
Mechanical seal (propeller side)	Silicon carbide
Painting	Bi-epoxy 200 µm (optional 400 µm)
Screws	Stainless steel A2-70 (optional A4)
Gaskets	NBR
Fixing system	AISI 304 stainless steel (optional AISI 316)

Installation

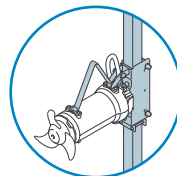

STANDARD

	standard 60 x 60
	optional 50 x 50
	80 x 80
	100 x 100

ZMD 030D A 3/6 AG 010

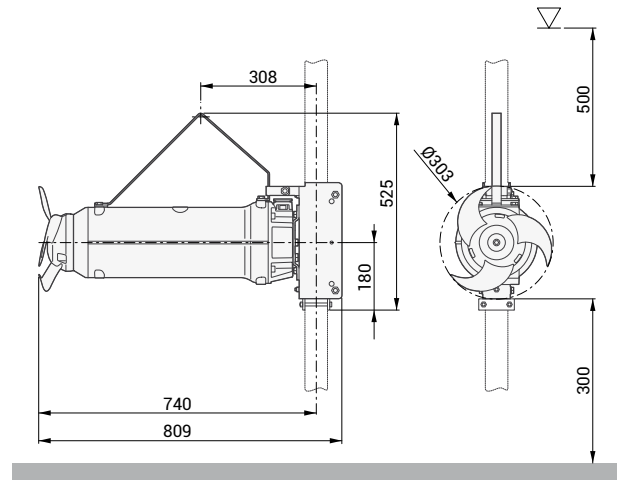

79 Kg (stand and guiding system excluded)

Product

Type	MIXER
Name	ZMD 030D A 3/6 AG 010
Configured Standard	-
ATEX marking	CE
	Optional (from DECEMBER 2019)

Motor

Rated Voltage	400 V
Frequency	50 Hz
Motor phases	3
Number of poles	6
Incoming power P2	3.0 kW
Electric power P1	3.5 kW
Rated current	6.8 A
rpm	960 rpm
Efficiency	85.6%
Cos φ	0.749
Rated torque	29.8 Nm
Start	DOL
Starting current	37.8 A
Starting torque	44.8 Nm
Degree of protection	IP 68
Insulation class	H
Motor efficiency class ref.	IE3

Gear unit

Type	-
Gear ratio	1

Propeller

Name	030D
Rated diameter	300 mm
Number of blades	3
rpm	960 rpm
Pp2	2.15 kW
Propeller thrust	660 N
Jet ring	Optional

Cable

Type	4G1.5 + 3x1
Length	10 m

Monitoring

Thermal protector	klixon
Leakage sensor	1 in mechanical seals chamber

Operating limits

Ambient temperature	0 ÷ 60°C
Max. density treated liquid	1100 Kg/m ³
pH treated liquid	6-14
Max. start per hour	20 /h (equally distributed)
Max. acoustic pressure level	Max 70 dB (A)
Operating mode	S1 – Continuous use

Construction materials

Case	Cast iron EN-GJL-250
Gear box	-
Propeller	AISI 316 (optional AISI 329)
Jet ring	-
Shaft	AISI 431
Mechanical seal (motor side)	Silicon carbide
Mechanical seal (propeller side)	Silicon carbide
Painting	Bi-epoxy 200 µm (optional 400 µm)
Screws	Stainless steel A2-70 (optional A4)
Gaskets	NBR
Fixing system	AISI 304 stainless steel (optional AISI 316)

Installation

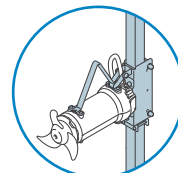

STANDARD

	standard 60 x 60
	optional 50 x 50
	80 x 80
	100 x 100

ZMD

ZMD 030E A 3.2/6 AG 010

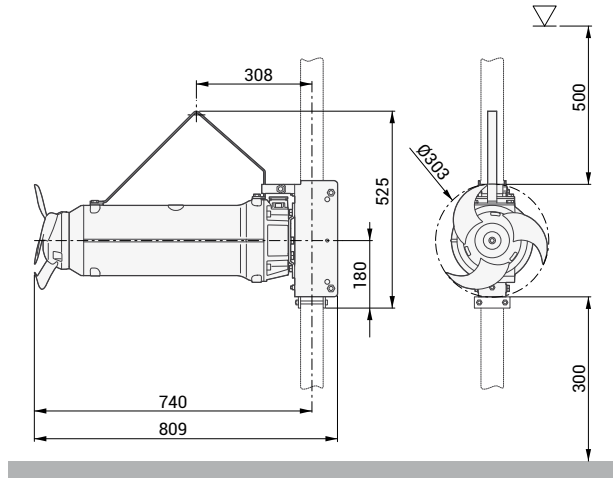

kg 79 Kg (stand and guiding system excluded)

Product

Type	MIXER
Name	ZMD 030E A 3.2/6 AG 010
Configured Standard	-
ATEX marking	CE Optional (from DECEMBER 2019)

Motor

Rated Voltage	400 V
Frequency	50 Hz
Motor phases	3
Number of poles	6
Incoming power P2	3.2 kW
Electric power P1	3.7 kW
Rated current	7.1 A
rpm	957 rpm
Efficiency	85.9%
Cos φ	0.757
Rated torque	31.9 Nm
Start	DOL
Starting current	37.6 A
Starting torque	45.0 Nm
Degree of protection	IP 68
Insulation class	H
Motor efficiency class ref.	IE3

Gear unit

Type	-
Gear ratio	1

Propeller

Name	030E
Rated diameter	300 mm
Number of blades	3
rpm	957 rpm
Pp2	2.99 kW
Propeller thrust	820 N
Jet ring	Optional

Cable

Type	4G1.5 + 3x1
Length	10 m

Monitoring

Thermal protector	klixon
Leakage sensor	1 in mechanical seals chamber

Operating limits

Ambient temperature	0 ÷ 60°C
Max. density treated liquid	1100 Kg/m ³
pH treated liquid	6-14
Max. start per hour	20 /h (equally distributed)
Max. acoustic pressure level	Max 70 dB (A)
Operating mode	S1 – Continuous use

Construction materials

Case	Cast iron EN-GJL-250
Gear box	-
Propeller	AISI 316 (optional AISI 329)
Jet ring	-
Shaft	AISI 431
Mechanical seal (motor side)	Silicon carbide
Mechanical seal (propeller side)	Silicon carbide
Painting	Bi-epoxy 200 µm (optional 400 µm)
Screws	Stainless steel A2-70 (optional A4)
Gaskets	NBR
Fixing system	AISI 304 stainless steel (optional AISI 316)

Installation

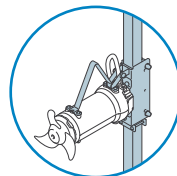

STANDARD

standard	60 x 60
optional	50 x 50
	80 x 80
	100 x 100

ZMD 040B A 3/8 AH 010

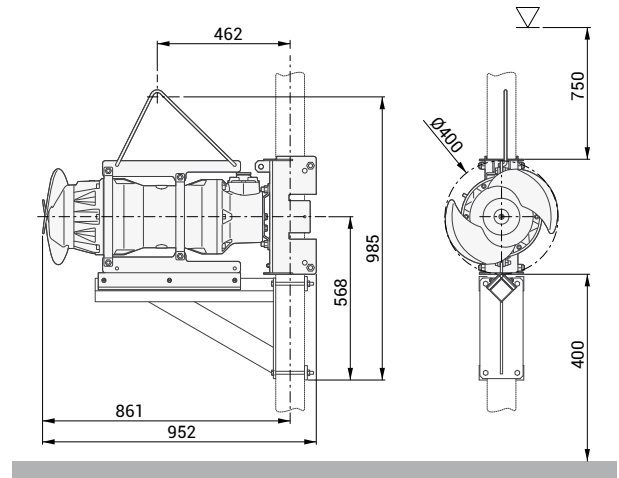

123 Kg (stand and guiding system excluded)

Product

Type	MIXER
Name	ZMD 040B A 3/8 AH 010
Configured Standard	-
ATEX marking	CE
	Optional (from DECEMBER 2019)

Motor

Rated Voltage	400 V
Frequency	50 Hz
Motor phases	3
Number of poles	8
Incoming power P2	3.0 kW
Electric power P1	3.6 kW
Rated current	7.3 A
rpm	716 rpm
Efficiency	83.5%
Cos φ	0.707
Rated torque	40 Nm
Start	DOL
Starting current	25.0 A
Starting torque	44.3 Nm
Degree of protection	IP 68
Insulation class	H
Motor efficiency class ref.	IE3

Gear unit

Type	-
Gear ratio	1

Propeller

Name	040B
Rated diameter	400 mm
Number of blades	2
rpm	716 rpm
Pp2	2.18 kW
Propeller thrust	625 N
Jet ring	Optional

Cable

Type	4G2.5 + 3x1
Length	10 m

Monitoring

Thermal protector	klixon
Leakage sensor	1 in mechanical seals chamber

Operating limits

Ambient temperature	0 ÷ 60°C
Max. density treated liquid	1100 Kg/m ³
pH treated liquid	6-14
Max. start per hour	20 /h (equally distributed)
Max. acoustic pressure level	Max 70 dB (A)
Operating mode	S1 – Continuous use

Construction materials

Case	Cast iron EN-GJL-250
Gear box	-
Propeller	AISI 316 (optional AISI 329)
Jet ring	-
Shaft	AISI 431
Mechanical seal (motor side)	Silicon carbide
Mechanical seal (propeller side)	Silicon carbide
Painting	Bi-epoxy 200 μm (optional 400 μm)
Screws	Stainless steel A2-70 (optional A4)
Gaskets	NBR
Fixing system	AISI 304 stainless steel (optional AISI 316)

Installation

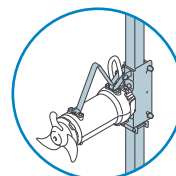

STANDARD

	standard 100 x 100
	optional 50 x 50
	60 x 60
	80 x 80

ZMD

ZMD 040D A 4.5/8 AH 010

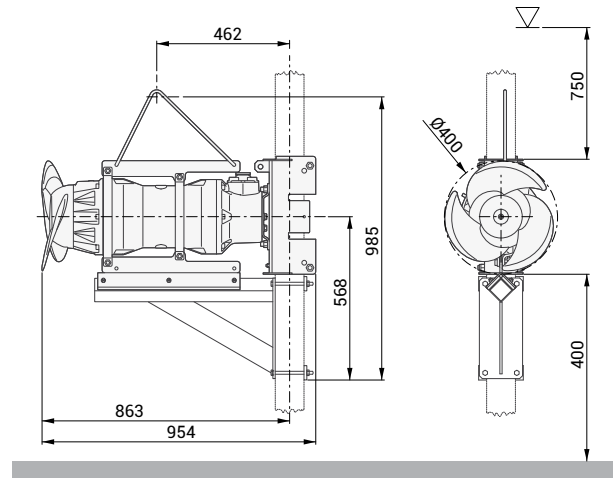

130 Kg (stand and guiding system excluded)

Product

Type	MIXER
Name	ZMD 040D A 4.5/8 AH 010
Configured Standard	-
ATEX marking	CE Optional (from DECEMBER 2019)

Motor

Rated Voltage	400 V
Frequency	50 Hz
Motor phases	3
Number of poles	8
Incoming power P2	4.5kW
Electric power P1	kW
Rated current	A
rpm	rpm
Efficiency	%
Cos φ	
Rated torque	Nm
Start	DOL
Starting current	A
Starting torque	Nm
Degree of protection	IP 68
Insulation class	H
Motor efficiency class ref.	IE3

Gear unit

Type	-
Gear ratio	1

Propeller

Name	040D
Rated diameter	400 mm
Number of blades	3
rpm	714 rpm
Pp2	4.0 kW
Propeller thrust	1060 N
Jet ring	Optional

Cable

Type	4G2.5 + 3x1
Length	10 m

Monitoring

Thermal protector	klixon
Leakage sensor	1 in mechanical seals chamber

Operating limits

Ambient temperature	0 ÷ 60°C
Max. density treated liquid	1100 Kg/m ³
pH treated liquid	6-14
Max. start per hour	20 /h (equally distributed)
Max. acoustic pressure level	Max 70 dB (A)
Operating mode	S1 – Continuous use

Construction materials

Case	Cast iron EN-GJL-250
Gear box	-
Propeller	AISI 316 (optional AISI 329)
Jet ring	-
Shaft	AISI 431
Mechanical seal (motor side)	Silicon carbide
Mechanical seal (propeller side)	Silicon carbide
Painting	Bi-epoxy 200 µm (optional 400 µm)
Screws	Stainless steel A2-70 (optional A4)
Gaskets	NBR
Fixing system	AISI 304 stainless steel (optional AISI 316)

Installation

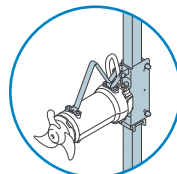

STANDARD

	standard 100 x 100
	optional 50 x 50
	60 x 60
	80 x 80

ZMR 065A A 4/4 BG 072

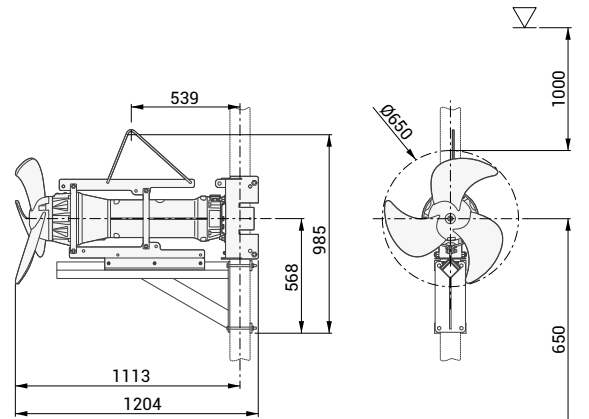

145 Kg (stand and guiding system excluded)

Product

Type	MIXER
Name	ZMR 065A A 4/4 BG 072
Configured	-
Standard	CE
ATEX marking	-

Motor

Rated Voltage	400 V
Frequency	50 Hz
Motor phases	3
Number of poles	4
Incoming power P2	4.0 kW
Electric power P1	4.5 kW
Rated current	8.4 A
rpm	1455 rpm
Efficiency	88.7 %
Cos φ	0.770
Rated torque	26.3 Nm
Start	DOL
Starting current	48.7 A
Starting torque	52.0 Nm
Degree of protection	IP 68
Insulation class	H
Motor efficiency class ref.	IE3

Gear unit

Type	1-stage planetary
Gear ratio	7.2

Propeller

Name	065A
Rated diameter	650 mm
Number of blades	3
rpm	202 rpm
Pp2	1.98 kW
Propeller thrust	1025 N
Jet ring	Optional

Cable

Type	4G2.5 + 3x1
Length	10 m

Monitoring

Thermal protector	klixon
Leakage sensor	1 in mechanical seals chamber

Operating limits

Ambient temperature	0 ÷ 60°C
Max. density treated liquid	1100 Kg/m ³
pH treated liquid	6-14
Max. start per hour	20 /h (equally distributed)
Max. acoustic pressure level	Max 70 dB (A)
Operating mode	S1 – Continuous use

Construction materials

Case	Cast iron EN-GJL-250
Gear box	-
Propeller	AISI 316 (optional AISI 329)
Jet ring	-
Shaft	AISI 431
Mechanical seal (motor side)	Silicon carbide
Mechanical seal (propeller side)	Silicon carbide
Painting	Bi-epoxy 200 μm (optional 400 μm)
Screws	Stainless steel A2-70 (optional A4)
Gaskets	NBR
Fixing system	AISI 304 stainless steel (optional AISI 316)

Installation

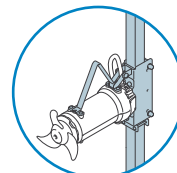



STANDARD

standard 100 x 100

ZMR

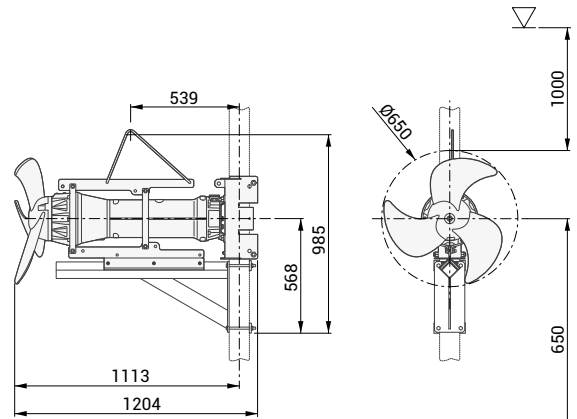
ZMR 065A A 4/4 BG 066



 145 Kg (stand and guiding system excluded)

Product

Type	MIXER
Name	ZMR 065A A 4/4 BG 066
Configured Standard	-
ATEX marking	CE

Motor

Rated Voltage	400 V
Frequency	50 Hz
Motor phases	3
Number of poles	4
Incoming power P2	4.0 kW
Electric power P1	4.5 kW
Rated current	8.4 A
rpm	1455 rpm
Efficiency	88.7 %
Cos φ	0.770
Rated torque	26.3 Nm
Start	DOL
Starting current	48.7 A
Starting torque	52.0 Nm
Degree of protection	IP 68
Insulation class	H
Motor efficiency class ref.	IE3

Gear unit

Type	1-stage planetary
Gear ratio	6.6

Propeller

Name	065A
Rated diameter	650 mm
Number of blades	3
rpm	219 rpm
Pp2	2.52 kW
Propeller thrust	1165 N
Jet ring	Optional

Cable

Type	4G2.5 + 3x1
Length	10 m

Monitoring

Thermal protector	klixon
Leakage sensor	1 in mechanical seals chamber

Operating limits

Ambient temperature	0 ÷ 40°C
Max. density treated liquid	1100 Kg/m ³
pH treated liquid	6-14
Max. start per hour	20 /h (equally distributed)
Max. acoustic pressure level	Max 70 dB (A)
Operating mode	S1 – Continuous use

Construction materials

Case	Cast iron EN-GJL-250
Gear box	-
Propeller	AISI 316 (optional AISI 329)
Jet ring	-
Shaft	AISI 431
Mechanical seal (motor side)	Silicon carbide
Mechanical seal (propeller side)	Silicon carbide
Painting	Bi-epoxy 200 μm (optional 400 μm)
Screws	Stainless steel A2-70 (optional A4)
Gaskets	NBR
Fixing systemc	AISI 304 stainless steel (optional AISI 316)

Installation

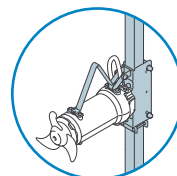

STANDARD

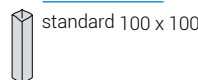

ZMR 065A A 5.5/4 BG 058

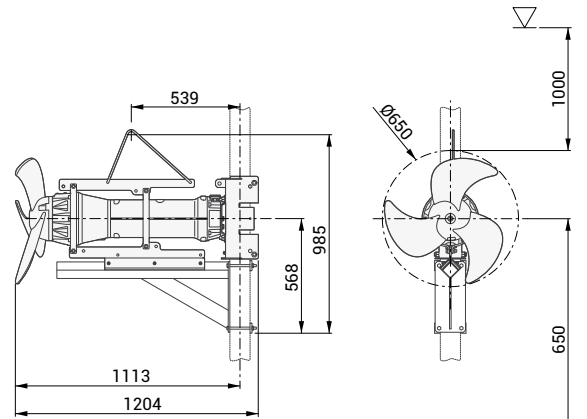

148 Kg (stand and guiding system excluded)

Product

Type	MIXER
Name	ZMR 065A A 5.5/4 BG 058
Configured	-
Standard	CE
ATEX marking	-

Motor

Rated Voltage	400 V
Frequency	50 Hz
Motor phases	3
Number of poles	4
Incoming power P2	5.5 kW
Electric power P1	6.1 kW
Rated current	11.7 A
rpm	1450 rpm
Efficiency	89.6 %
Cos φ	0.760
Rated torque	36.2 Nm
Start	DOL
Starting current	64.0 A
Starting torque	72.4 Nm
Degree of protection	IP 68
Insulation class	H
Motor efficiency class ref.	IE3

Gear unit

Type	1-stage planetary
Gear ratio	5.8

Propeller

Name	065A
Rated diameter	650 mm
Number of blades	3
rpm	251 rpm
Pp2	3.80 kW
Propeller thrust	1500 N
Jet ring	Optional

Cable

Type	4G2.5 + 3x1
Length	10 m

Monitoring

Thermal protector	klixon
Leakage sensor	1 in mechanical seals chamber

Operating limits

Ambient temperature	0 ÷ 60°C
Max. density treated liquid	1100 Kg/m ³
pH treated liquid	6-14
Max. start per hour	20 /h (equally distributed)
Max. acoustic pressure level	Max 70 dB (A)
Operating mode	S1 – Continuous use

Construction materials

Case	Cast iron EN-GJL-250
Gear box	-
Propeller	AISI 316 (optional AISI 329)
Jet ring	-
Shaft	AISI 431
Mechanical seal (motor side)	Silicon carbide
Mechanical seal (propeller side)	Silicon carbide
Painting	Bi-epoxy 200 µm (optional 400 µm)
Screws	Stainless steel A2-70 (optional A4)
Gaskets	NBR
Fixing system	AISI 304 stainless steel (optional AISI 316)

Installation

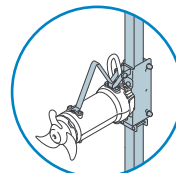



STANDARD

standard 100 x 100

ZMR

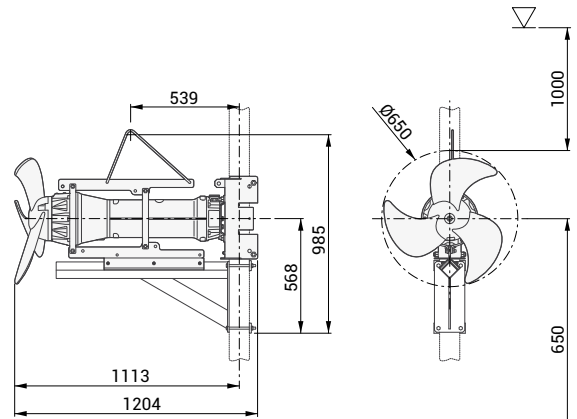
ZMR 065A A 5.5/4 BG 054



 148 Kg (stand and guiding system excluded)

Product

Type	MIXER
Name	ZMR 065A A 5.5/4 BG 054
Configured	-
Standard	CE
ATEX marking	-

Motor

Rated Voltage	400 V
Frequency	50 Hz
Motor phases	3
Number of poles	4
Incoming power P2	5.5 kW
Electric power P1	6.1 kW
Rated current	11.7 A
rpm	1450 rpm
Efficiency	89.6 %
Cos φ	0.760
Rated torque	36.2 Nm
Start	DOL
Starting current	64.0 A
Starting torque	72.4 Nm
Degree of protection	IP 68
Insulation class	H
Motor efficiency class ref.	IE3

Gear unit

Type	1-stage planetary
Gear ratio	5.4

Propeller

Name	065A
Rated diameter	650 mm
Number of blades	3
rpm	267 rpm
Pp2	4.40 kW
Propeller thrust	1700 N
Jet ring	Optional

Cable

Type	4G2.5 + 3x1
Length	10 m

Monitoring

Thermal protector	klixon
Leakage sensor	1 in mechanical seals chamber

Operating limits

Ambient temperature	0 ÷ 60°C
Max. density treated liquid	1100 Kg/m ³
pH treated liquid	6-14
Max. start per hour	20 /h (equally distributed)
Max. acoustic pressure level	Max 70 dB (A)
Operating mode	S1 – Continuous use

Construction materials

Case	Cast iron EN-GJL-250
Gear box	-
Propeller	AISI 316 (optional AISI 329)
Jet ring	-
Shaft	AISI 431
Mechanical seal (motor side)	Silicon carbide
Mechanical seal (propeller side)	Silicon carbide
Painting	Bi-epoxy 200 µm (optional 400 µm)
Screws	Stainless steel A2-70 (optional A4)
Gaskets	NBR
Fixing system	AISI 304 stainless steel (optional AISI 316)

Installation

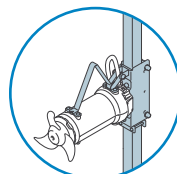

STANDARD

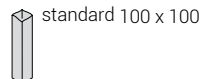

ZMR 065A A 7.5/4 AH 049

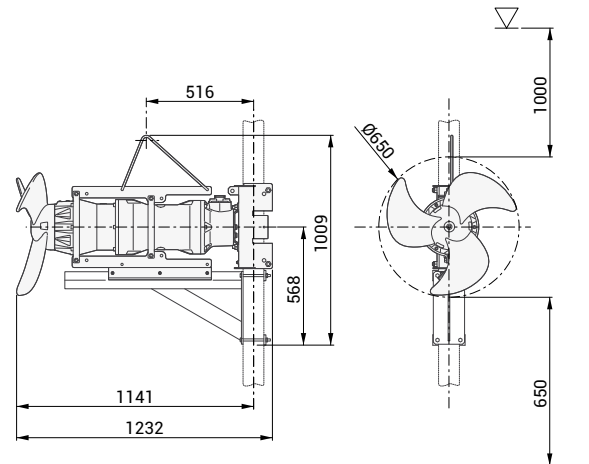

184 Kg (stand and guiding system excluded)

Product

Type	MIXER
Name	ZMR 065A A 7.5/4 AH 049
Configured	-
Standard	CE
ATEX marking	-

Motor

Rated Voltage	400 V
Frequency	50 Hz
Motor phases	3
Number of poles	4
Incoming power P2	7.5 kW
Electric power P1	8.3 kW
Rated current	14.5 A
rpm	1460 rpm
Efficiency	90.4 %
Cos φ	0.830
Rated torque	49.1 Nm
Start	DOL
Starting current	96.6 A
Starting torque	119.2 Nm
Degree of protection	IP 68
Insulation class	H
Motor efficiency class ref.	IE3

Gear unit

Type	1-stage planetary
Gear ratio	4.9

Propeller

Name	065A
Rated diameter	650 mm
Number of blades	3
rpm	300 rpm
Pp2	5.80 kW
Propeller thrust	2100 N
Jet ring	Optional

Cable

Type	4G6
Length	10 m

Monitoring

Thermal protector	klixon
Leakage sensor	1 in mechanical seals chamber

Operating limits

Ambient temperature	0 ÷ 60°C
Max. density treated liquid	1100 Kg/m ³
pH treated liquid	6-14
Max. start per hour	20 /h (equally distributed)
Max. acoustic pressure level	Max 70 dB (A)
Operating mode	S1 – Continuous use

Construction materials

Case	Cast iron EN-GJL-250
Gear box	-
Propeller	AISI 316 (optional AISI 329)
Jet ring	-
Shaft	AISI 431
Mechanical seal (motor side)	Silicon carbide
Mechanical seal (propeller side)	Silicon carbide
Painting	Bi-epoxy 200 µm (optional 400 µm)
Screws	Stainless steel A2-70 (optional A4)
Gaskets	NBR
Fixing system	AISI 304 stainless steel (optional AISI 316)

Installation

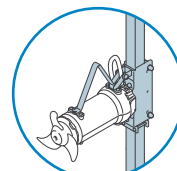

STANDARD

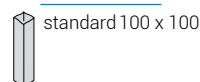

Installations and accessories

To guarantee top mixer performance, ZENIT has developed a wide range of accessories for adjusting devices' positions in the tank and lifting and removing them without having to drain the system.

Designed for easy installation and generously sized to guarantee durability, accessories are available in galvanised or stainless steel.

The recommended installation modes are:

Bottom installation (fig. A) and pendular installation (fig. B)

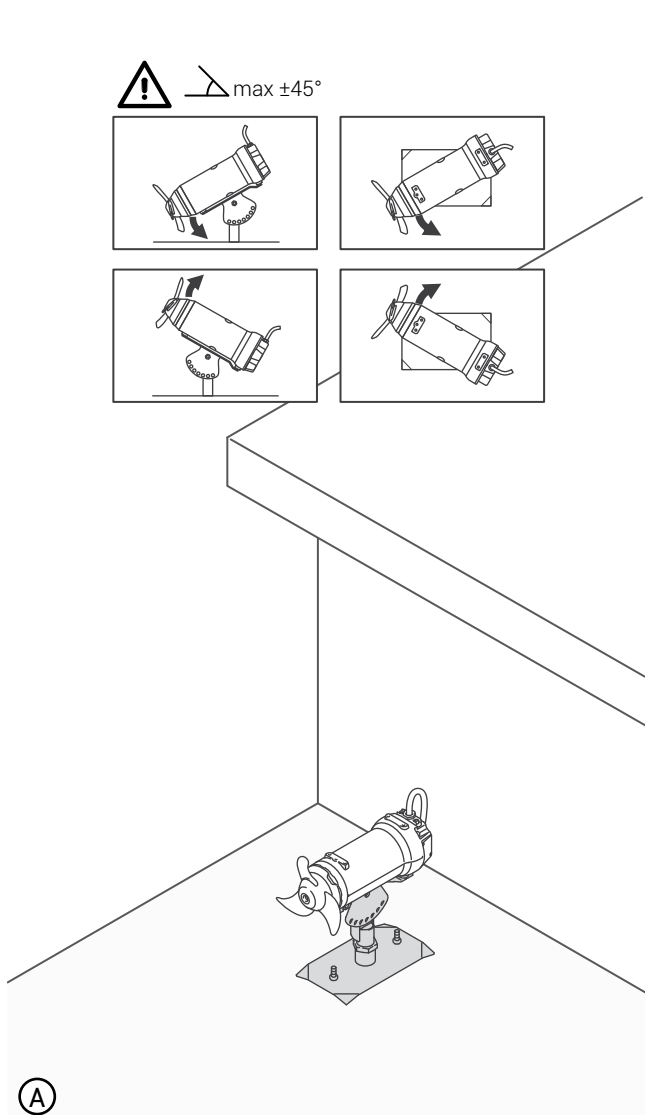

Permanent installation, with the mixer connected to a base anchored to the bottom of the tank.

A special adjustment plate allows the mixer's horizontal and vertical position to be set as specifically required by the system.

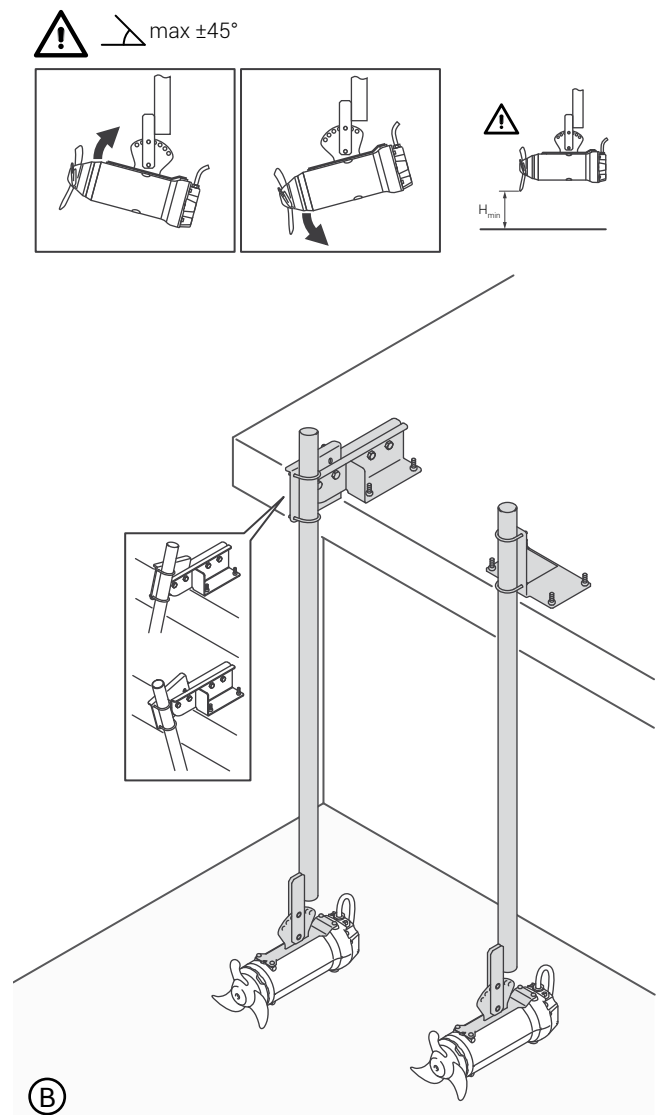

Mobile installation in which the mixer can be both installed and removed with the tank full.

The mixer is suspended from a suspension pipe and fixed to a mounting bracket; it can be adjusted both horizontally and vertically

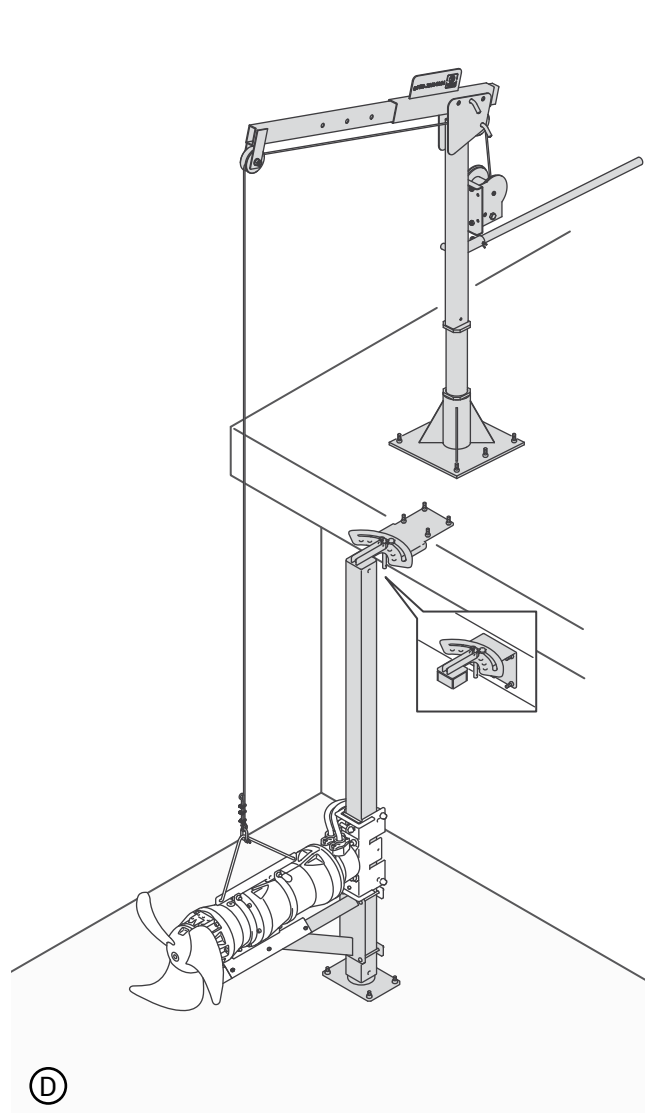
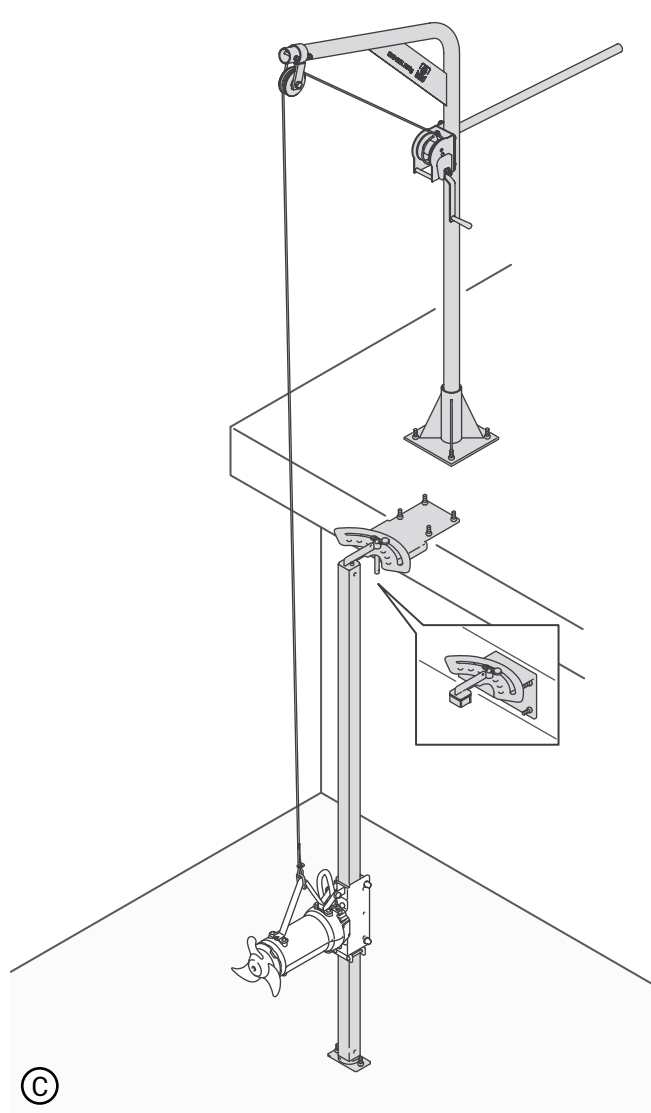

Mast installation (fig. C and D)

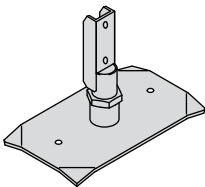
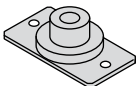
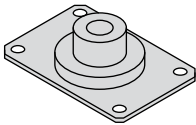
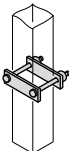
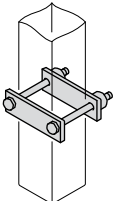
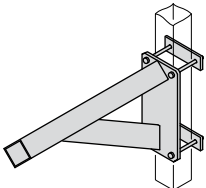
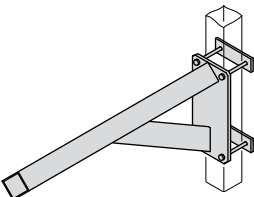

The most widely used installation mode, suitable for mixers of any shape and size.
 The mixer, fitted with a runner which is also compatible with existing installations, slides along a square post and can be removed with no need to drain the tank, thanks to rugged lifting jib cranes.
 The mixer can be horizontally adjusted for the best possible position, while vertical adjustment is possible with the aid of special optional runners.

Accessories

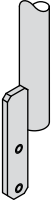
	Code	Description	Material	Suitable for mixers
	27.986	Base for bottom mixer installation	AISI 304	ZMD 020 ZMD 030
	27.814	60x60 mm base pole mixer	AISI 304	ZMD 020 ZMD 030
	27.812	100x100 mm base pole mixer	AISI 304	ZMD 030 ZMD 040 ZMR 065
	27.982	Stop fitting for 60x60 mm pole	AISI 304	ZMD 020 ZMD 030
	26.157	Stop fitting for 100x100 mm pole	AISI 304	ZMD 030
	28.715	Stop fitting support for 100x100 mm pole - ZMD	AISI 304	ZMD 040
	28.056	Stop fitting support for 100x100 mm pole - ZMR	AISI 304	ZMR 065

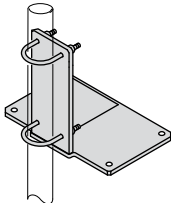
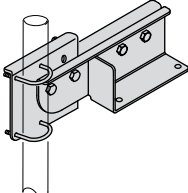
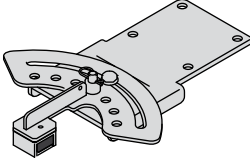
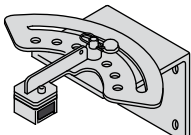
	27.992	Guide for suspended installation	AISI 304	ZMD 020
	27.821	60x60 mm pole Lenght = 3 m	AISI 304	ZMD 020 ZMD 030
	-	60x60 mm pole Lenght = 6 m	AISI 304	ZMD 020 ZMD 030
	27.818	100x100 mm pole Lenght = 3 m	AISI 304	ZMD 030 ZMD 040 ZMR 065
	-	100x100 mm pole Lenght = 6 m	AISI 304	ZMD 030 ZMD 040 ZMR 065
	27.996	Fixed upper bracket floor for Ø 2" pole	AISI 304	ZMD 020
	28.032	Adjustable upper bracket a floor for Ø 2" pole	AISI 304	ZMD 020
	28.018	Upper bracket floor for 60x60 mm pole	AISI 304	ZMD 020 ZMD 030
	28.017	Upper bracket wall for 60x60 mm pole	AISI 304	ZMD 020 ZMD 030

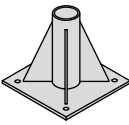
	28.016	Upper bracket floor for 100x100 mm pole	AISI 304	ZMD 030 ZMD 040 ZMR 065
	28.015	Upper bracket wall for 100x100 mm pole	AISI 304	ZMD 030 ZMD 040 ZMR 065
	28.067	Crane for Ø60 mm pole (max capacity 200 kg)	Acciaio zincato	ZMD 020 ZMD 030
	28.399	Crane for Ø100 mm pole (max capacity 450 kg)	Acciaio zincato	ZMD 030 ZMD 040 ZMR 065
	24.659	Lifting hook	Acciaio zincato	ZMD 020 ZMD 030 ZMD 040 ZMR 065
	28.074	Base for crane Ø60 mm pole	AISI 304	ZMD 020 ZMD 030
	28.073	Base for crane Ø100 mm pole	AISI 304	ZMD 030 ZMD 040 ZMR 065

