

APN

motralec

4 rue Lavoisier . ZA Lavoisier . 95223 HERBLAY CEDEX
 Tel. : 01.39.97.65.10 / Fax. : 01.39.97.68.48
 Demande de prix / e-mail : service-commercial@motralec.com
www.motralec.com



High head impeller

General characteristics

- High head impeller
- 1,8 ÷ 4,1 kW motor power
- 2 poles
- GAS 1 1/2" - GAS 2" DN32 horizontal delivery port
- max 10 mm free passage

Electromechanical assembly

Electromechanical assembly in GJL-250 cast iron, for submerged operation. Seal set comprising 2 (two) opposing silicon carbide mechanical seals in inspectable oil sump. Ecological dry motor. Separate pump body. Series available in explosion-proof version.

Applications

Suitable for clear wastewater, rainwater and seepage. The considerable manometric head guarantees excellent results for the creation of water features and decorative fountains; suitable for use in agriculture, irrigation and the fish processing sector. The pump is also available in explosion-proof version with ATEX certification. This series is prefitted for installation of the ZENIT cooling system for dry or semi-submerged installation.

Construction materials

Case	Grey Cast Iron - EN-GJL 250
Impeller material	Cast iron EN-GJL-250
Nuts and bolts	Stainless Steel - Class A2-70
Standard gasket	Rubber - NBR
Shaft	Stainless Steel - AISI 420
Cooling jacket	Carbon Steel - Fe360 ÷ Fe370
Set of standard mechanical seals	Two Silicon carbide mechanical seals (2SiC)

operating limits

Maximum operating temperature	40 °C
PH of treated fluid	6 to 10 pH
Viscosity of treated fluid	1 mm ² /s
Maximum immersion depth	20 m
Density of treated fluid	1 Kg/dm ³
Maximum acoustic pressure	70 dB
max starts per hour	10

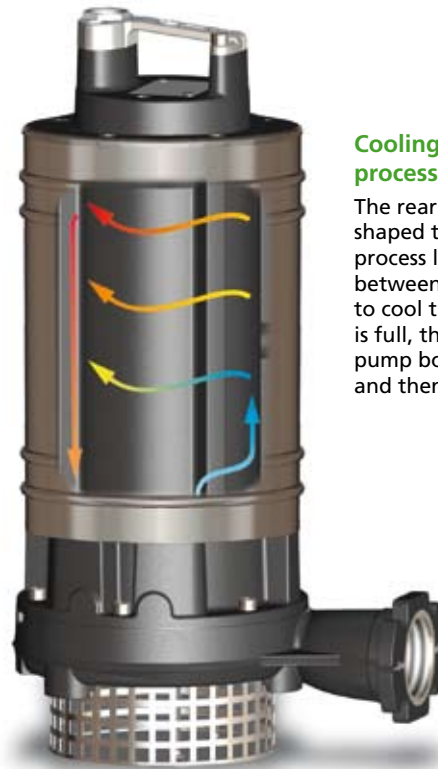
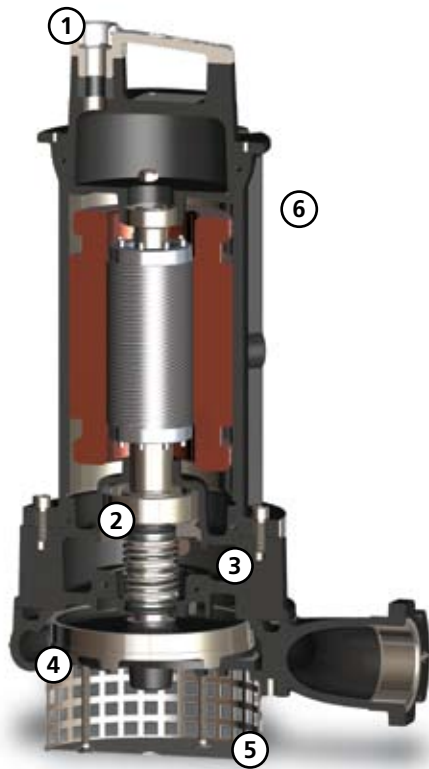

Cooling by means of process liquid

The rear of the impeller is specially shaped to convey some of the process liquid into the cavity between the body and the jacket to cool the motor. Once the cavity is full, the liquid is drawn into the pump body along a special pipe and then expelled.



Cable Gland

Cable gland system to guarantee perfect water-tightness. The GAS thread ring-nut can be removed to fix a rigid or flexible duct to the cable gland to protect the power supply cable



Mechanical seals

Two mechanical seals in silicon carbide (2SiC)



Oil sump

Large oil sump to guarantee longer mechanical seal lifetime



Anti-clogging system

The special design of the hydraulic part ensures the expulsion of suspended solids and prevents fouling of the impeller



Intake strainer

Intake strainer in stainless steel

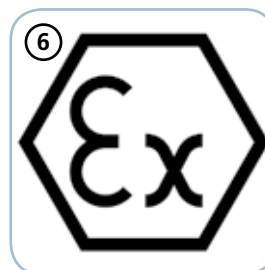

EX

Models available on request with ATEX certification, suitable for installation in the presence of potentially explosive gases, powders and liquids

APN

Models with horizontal GAS 1 1/2" threaded - DN32 PN6 flanged delivery port - 2 poles

Performances

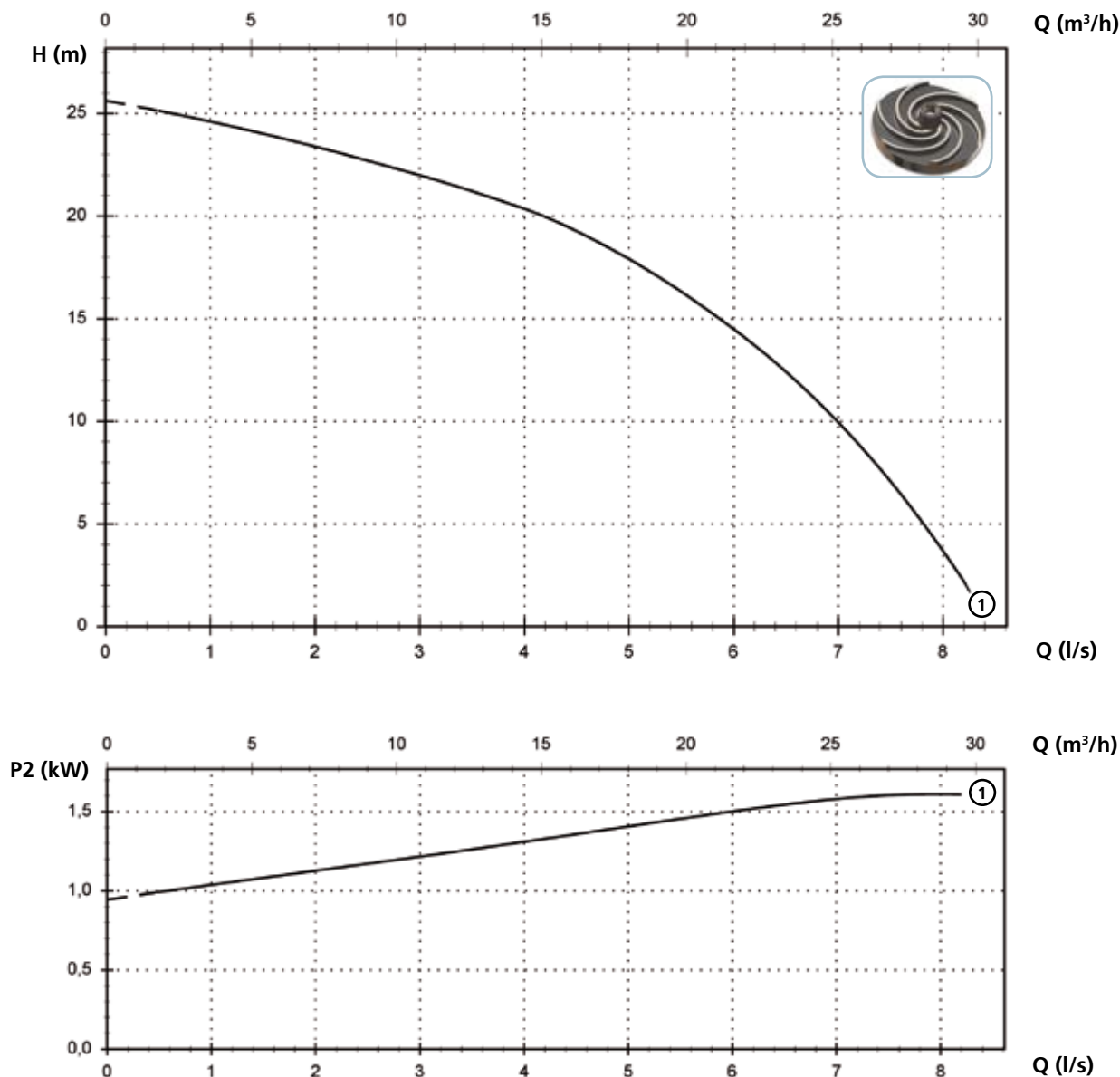

Technical data

	V	Phases	P1 (kW)	P2 (kW)	A	Rpm	Ø	Cable (*)	Free passage
① APN 250/2/G40H A1DM/50	230	1	2.7	1.8	12.5	2900	G 1 1/2" - DN32 PN6	A - B	10 mm
① APN 250/2/G40H A1DT/50	400	3	2.5	1.8	4.3	2900	G 1 1/2" - DN32 PN6	A - B	10 mm

(*) A = 07RN-F 4G1.5+3x1 - 10 m (standard version). Electrical and mechanical features are equal to the cable H07RN-F
 B = NSSHOU-J 4G1.5+2x0.75 - 10 m (ATEX version)

Models with horizontal GAS 2" threaded - DN32 PN6 flanged delivery port - 2 poles

Performances

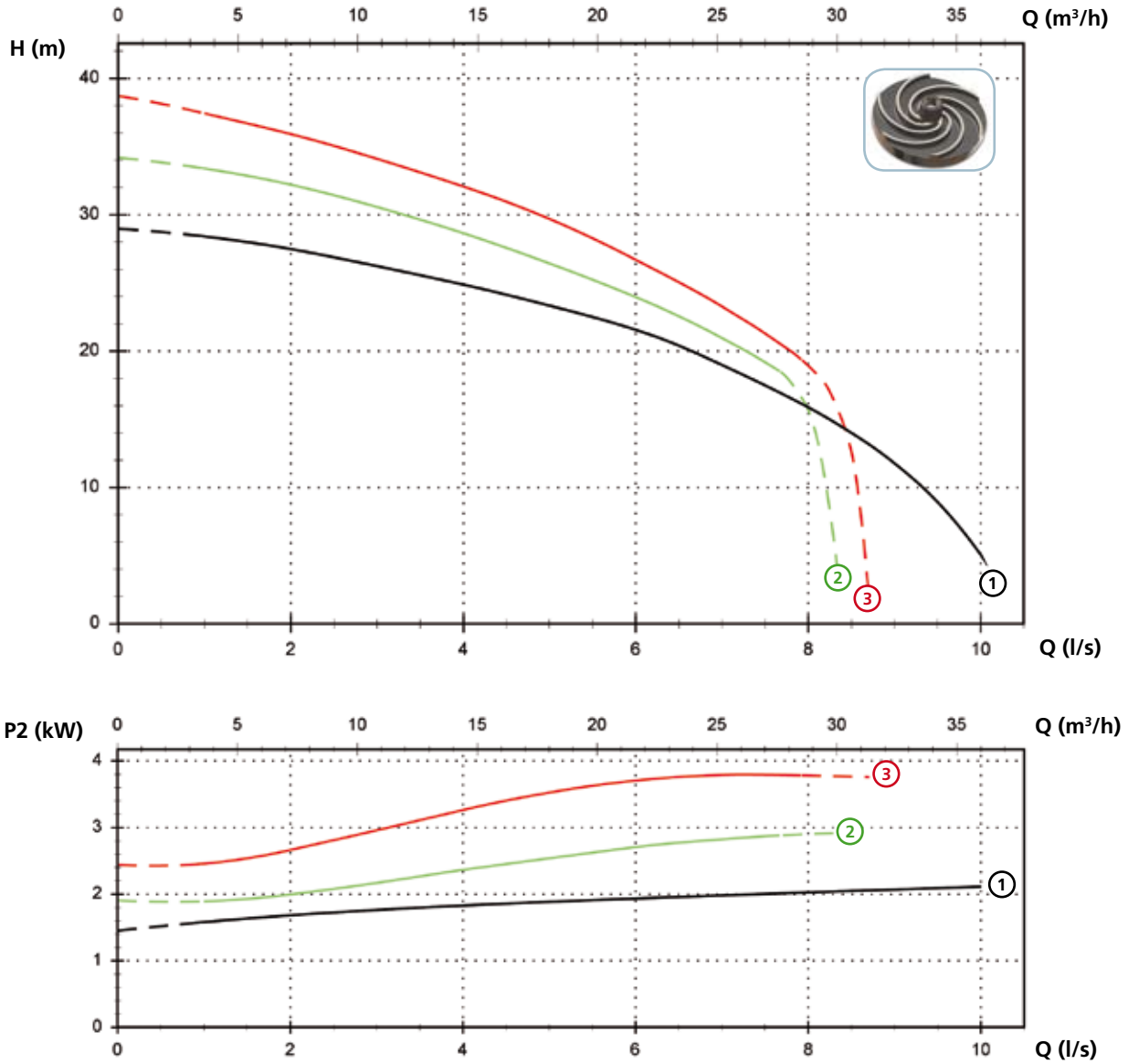

Technical data

	V	Phases	P1 (kW)	P2 (kW)	A	Rpm	Ø	Cable (*)	Free passage
① APN 300/2/G50H A1DT/50	400	3	3.7	2.2	5.1	2900	G 2"- DN32 PN6	A - B	10 mm
② APN 400/2/G50H A1FT/50	400	3	4.0	3	6.7	2900	G 2"- DN32 PN6	A - B	10 mm
③ APN 550/2/G50H A1FT/50	400	3	5.0	4.1	8.7	2900	G 2"- DN32 PN6	A - B	10 mm

(*) A = 07RN-F 4G1.5+3x1 - 10 m (standard version). Electrical and mechanical features are equal to the cable H07RN-F
 B = NSSHO-U-J 4G1.5+2x0.75 - 10 m (ATEX version)

APN

Versions available

(Key to versions on page 15)

	Electrical variants													Cooling		Mechanical seals					
	N A E	T	T C	T C D	T C D T	T C D G	T C G	T C S T	T C S G T	T S	T R	T R G	T F T	C G F T	N	CC	2SIC	SICM	SICAL	2SICAL	
APN 250/2/G40H A1DM/50				●											●	●	●				
APN 250/2/G40H A1DT/50		●							●						●	●	●				
APN 300/2/G50H A1DT/50		●							●						●	●	●				
APN 400/2/G50H A1FT/50		●							●						●	●	●				
APN 550/2/G50H A1FT/50		●							●						●	●	●				

NOTE: For single phase pumps thermal protections into the winding have to be connected to the electrical panel.
 Start capacitor inside the pump.
 Circuit breaker supplied but not connected to the pump cable.
 The use of an electrical panel as circuit breaker housing is mandatory.
 For installation please see use and maintenance instructions booklet.
 The version complete with probe is not available with ATEX certificate.

Overall dimensions and weights

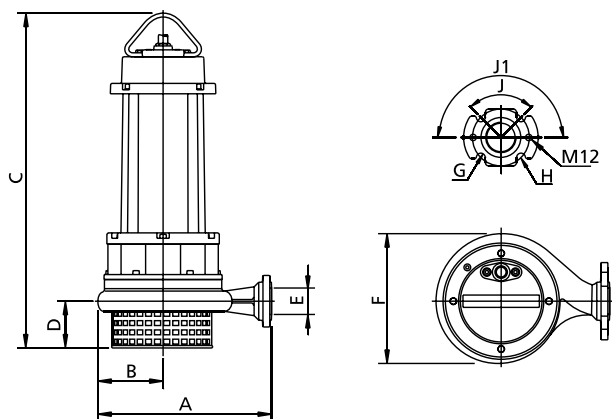

	A	B	C	D	E	F	G	H	J	J1	kg
APN 250/2/G40H A1DM(T)/50	265	105	530	80	G 1 1/2"	215	14	90	90°	180°	43
APN 300/2/G50H A1DT/50	305	110	530	80	G 2"	225	14	90	90°	180°	46
APN 400/2/G50H A1FT/50	350	130	660	80	G 2"	265	14	90	90°	180°	68
APN 550/2/G50H A1FT/50	350	130	660	80	G 2"	265	14	90	90°	180°	71

Measurements in mm

Packaging dimension

	A	B	C
APN 250/2/G40H A1DM(T)/50	725	445	415
APN 300/2/G50H A1DT/50	725	445	415
APN 400/2/G50H A1FT/50	725	445	415
APN 550/2/G50H A1FT/50	725	445	415

Dimension in mm

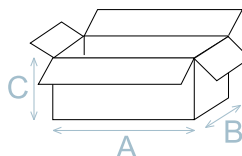

Installations available

