

Wilo-CronoNorm-NL, NLG

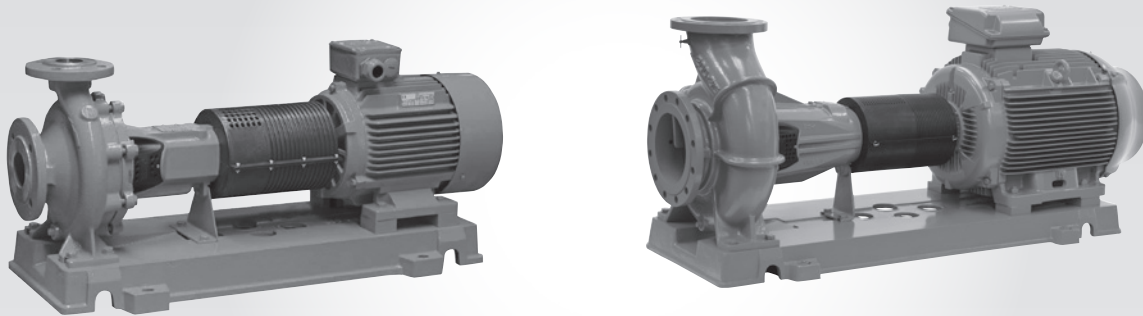

en Installation and operating instructions

de	Einbau- und Betriebsanleitung	3
en	Installation and operating instructions	53
fr	Notice de montage et de mise en service	103

1	General	55
2	Safety	55
2.1	Indication of instructions in the operating instructions	55
2.2	Personnel qualifications	56
2.3	Danger in the event of non-observance of the safety instructions	56
2.4	Safety consciousness on the job	56
2.5	Safety instructions for the operator	56
2.6	Safety instructions for installation and maintenance work	57
2.7	Unauthorised modification and manufacture of spare parts	58
2.8	Improper use	58
3	Transport and interim storage	58
3.1	Shipping	58
3.2	Transport for installation/dismantling purposes	59
3.3	Removing/replacing corrosion protection (only NL pumps).....	60
4	Intended use	61
5	Product information	61
5.1	Type key	62
5.2	Technical data	62
5.3	Scope of delivery	63
5.4	Accessories	63
6	Description and function	63
6.1	Description of the product	63
6.2	Design set-up	63
6.3	Anticipated noise levels for standard pumps	64
6.4	Permissible forces and torques on the pump flanges	65
7	Installation and electrical connection	67
7.1	Preparation	67
7.2	Setting up the pump alone (variant B, according to Wilo variant key)	67
7.3	Installation on a base of the pump unit	68
7.4	Pipework	70
7.5	Aligning the unit	71
7.6	Electrical connection	73
7.7	Protective devices	74
8	Commissioning / decommissioning	74
8.1	Safety	74
8.2	Filling and bleeding	74
8.3	Checking the direction of rotation	75
8.4	Switching on the pump	75
8.5	Leak check	76
8.6	Switch-on frequency	77
8.7	Switching off the pump and temporary shutdown	77
8.8	Decommissioning and storage	77
9	Maintenance/repair	78
9.1	Safety	78
9.2	Operation monitoring	79
9.3	Maintenance work	79
9.4	Draining and cleaning	79
9.5	Dismantling	80
9.6	Installation	85
9.7	Screw tightening torques	89

10	Faults, causes and remedies	90
10.1	Faults	90
10.2	Causes and remedies	91
11	Spare parts	92
11.1	Spare parts lists, Wilo-CronoNorm-NL	93
11.2	Spare parts lists, Wilo-CronoNorm-NLG	97
12	Disposal	101

English

1 General

About this document

The language of the original operating instructions is German. All other languages of these instructions are translations of the original operating instructions.

These installation and operating instructions are an integral part of the product. They must be kept readily available at the place where the product is installed. Strict adherence to these instructions is a precondition for the proper use and correct operation of the product.

The installation and operating instructions correspond to the relevant version of the product and the underlying safety regulations and standards valid at the time of going to print.

EC declaration of conformity:

A copy of the EC declaration of conformity is a component of these operating instructions.

If a technical modification is made on the designs named there without our agreement or the declarations made in the installation and operating instructions on product/personnel safety are not observed, this declaration loses its validity.

2 Safety

These operating instructions contain basic information which must be adhered to during installation, operation and maintenance. For this reason, these operating instructions must, without fail, be read by the service technician and the responsible specialist/operator before installation and commissioning.

It is not only the general safety instructions listed under the main point "safety" that must be adhered to but also the special safety instructions with danger symbols included under the following main points.

2.1 Indication of instructions in the operating instructions

Symbols



General danger symbol



Danger due to electrical voltage



NOTE

Signal words

DANGER!

Acutely dangerous situation.

Non-observance results in death or the most serious of injuries.

WARNING!

The user can suffer (serious) injuries. "Warning" implies that (serious) injury to persons is probable if this note is disregarded.

CAUTION!

There is a risk of damaging the product/unit. "Caution" concerns possible damage to the product that could occur if this note is disregarded.

NOTE:

Useful information on handling the product. It draws attention to possible problems.

Information that appears directly on the product, such as:

- direction of rotation arrow
- rating plate
- warning sticker

must be strictly complied with and kept in legible condition.

2.2 Personnel qualifications

The installation, operating and maintenance personnel must have the appropriate qualifications for this work. Area of responsibility, terms of reference and monitoring of the personnel are to be ensured by the operator. If the personnel are not in possession of the necessary knowledge, they are to be trained and instructed. This can be accomplished if necessary by the manufacturer of the product at the request of the operator.

2.3 Danger in the event of non-observance of the safety instructions

Non-observance of the safety instructions can result in risk of injury to persons and damage to the environment and the product/unit. Non-observance of the safety instructions results in the loss of any claims to damages.

In detail, non-observance can, for example, result in the following risks:

- Danger to persons from electrical, mechanical and bacteriological influences
- Damage to the environment due to leakage of hazardous materials
- Property damage
- Failure of important product/unit functions
- Failure of required maintenance and repair procedures.

2.4 Safety consciousness on the job

The safety instructions included in these installation and operating instructions, the existing national regulations for accident prevention together with any internal working, operating and safety regulations of the operator are to be complied with.

2.5 Safety instructions for the operator



This appliance is not intended for use by persons (including children) with reduced physical, sensory or mental capabilities, or lack of experience and knowledge, unless they have been given supervision or instruction concerning use of the appliance by a person responsible for their safety.

Children should be supervised to ensure that they do not play with the appliance.

- If hot or cold components on the product/the unit lead to hazards, local measures must be taken to guard them against touching.
- Guards protecting against touching moving components (such as the coupling) must not be removed whilst the product is in operation.
- Leakages (e.g. from a shaft seal) of hazardous fluids (e.g. explosive, toxic or hot) must be conveyed away so that no danger to persons or to the environment arises. National statutory provisions are to be complied with.
- Danger from electrical current must be eliminated. Local directives or general directives [e.g. IEC, VDE etc.] and local energy supply companies must be adhered to.
- The area near the pump unit must be kept free of contaminants to eliminate the chance of a fire or an explosion due to contact of contaminants with hot unit surfaces.
- The instructions in this manual apply to the standard equipment design. This book does not discuss all details or frequent deviations. Additional information is available from the manufacturer.
- If there are any doubts about the function or setting of parts of the equipment, contact the manufacturer immediately.

English

Shearing hazards	Never put fingers, hands, arms, etc. in the suction or outlet openings or another opening (such as the hole of the venting screw). To avoid the penetration of foreign objects, leave the protective covers or packaging on until they have to be removed for installation. If the packaging or covers of suction or outlet openings are removed for inspection purposes, they must be put back on afterwards to protect the pump and ensure safety.
Thermal hazards	Most drive surfaces can become hot during operation. The areas of the stuffing box and bearing bracket on the pump can become hot in the event of a malfunction or incorrect setting. The surfaces in question also remain hot after switching off the unit. These surfaces may only be touched with caution. If required, wear protective gloves if these surfaces must be touched while they are hot. If the packing is too tightly sealed, the water coming out of the stuffing box can be so hot that there is a danger of scalding. Make sure that the drained water is not too hot for more intensive contact with skin. Components which are subject to temperature fluctuations, so that touching them can therefore be dangerous, must be protected by suitable devices.
Hazard due to articles of clothing being caught, etc.	Do not wear loose or frayed clothing or jewellery which could be caught by the product. The devices for protecting against accidental contact with moving parts (e.g. coupling protection) may only be dismantled when the system is at a standstill. The pump must never be put into operation without these protective devices.
Hazards due to noise	If the noise level of the pump exceeds 80 dB(A), the valid health protection and safety regulations must be complied so that operating personnel of the system aren't exposed to excessive noise. The sound pressure specifications on the rating plate of the motor must be observed. The sound pressure value of the pump is generally about the same value as that of the motor +2 dB(A).
Leakage	Leakage of dangerous (explosive, toxic, hot) substances which come from the pump (e.g. shaft seal) must be avoided to protect people and the environment, under the observation of local standards and regulations. The pump must never be operated without fluid. Otherwise, this can cause the shaft seal to be destroyed, thereby endangering people and the environment.
2.6 Safety instructions for installation and maintenance work	The operator must ensure that all installation and maintenance work is carried out by authorised and qualified personnel, who are sufficiently informed from their own detailed study of the operating instructions. Work to the product/unit must only be carried out when at a standstill. It is mandatory that the procedure described in the installation and operating instructions for shutting down the product/unit be complied with. Immediately on conclusion of the work, all safety and protective devices must be put back in position and/or recommissioned. Pumps which pump hazardous fluids must be decontaminated.

- 2.7 Unauthorised modification and manufacture of spare parts**
- Unauthorised modification and manufacture of spare parts will impair the safety of the product/personnel and will make void the manufacturer's declarations regarding safety.
- Modifications to the product are only permissible after consultation with the manufacturer. Original spare parts and accessories authorised by the manufacturer ensure safety. The use of other parts will absolve us of liability for consequential events.
- 2.8 Improper use**
- The operating safety of the supplied product is only guaranteed for conventional use in accordance with Section 4 of the operating instructions. The limit values must on no account fall under or exceed those specified in the catalogue/data sheet.
- 3 Transport and interim storage**
- 3.1 Shipping**
- The pump is lashed to a pallet ex works and is protected against dirt and moisture.
- Transport inspection**
- On arrival, inspect the pump immediately for any transport damage. If damage is found, the necessary procedures involving the forwarding agent must be taken within the specified period.
- Storage**
- Before installation, the pump must be kept dry, frost-free and protected from mechanical damage.
-  **NOTE:**
Improper storage can lead to damage to the equipment, which is excluded from the guarantee and warranty.
- Short-term storage (less than three months):**
- If it is required to store a pump before its installation for a short time, keep it in a dry, clean and ventilated place, which is free of vibrations, moisture and fast/extreme temperature differences. Protect the bearings and couplings from sand, gravel and other foreign objects. To prevent rust and bearing seizing, lubricate the unit and turn the rotor by hand by several rotations at least once a week.
- Long-term storage (more than three months):**
- If it is planned to store the pump over a longer period of time, additional precautionary measures must be taken. All rotating parts must be coated with a suitable protective medium to protect them from rust. If the pump should be stored for more than a year, consult the manufacturer.
-  **CAUTION! Risk of damage due to incorrect packaging!**
If the pump is transported again at a later time, it must be packaged so that it cannot be damaged during transport.
- Use the original packaging for this, or choose equivalent packaging.

English

3.2 Transport for installation/ dismantling purposes

General safety instructions



WARNING! Danger of bodily injury!

Improper transport can lead to personal injury (e.g. crushing injuries).

- Only have work for lifting or moving the unit done by professionals.
- To lift the unit, never attach hooks or slings to shafts.
- Never lift the pump via the lug in the bearing bracket.
- When manually lifting components, work with proper lifting techniques.
- Never stand beneath a suspended load.
- The existing accident prevention regulations must be complied with.
- Always wear protective clothing, protective gloves and protective goggles when working.

Containers, boxes, pallets, and boxes made of wood can be unloaded with a forklift or by using lifting belts, depending on the size and construction.

Attaching the transport ropes



CAUTION! Risk of damaging the pump!

To ensure proper alignment, all equipment is pre-installed. If dropped or if improperly handled, there is a risk of misalignment or deficient performance.

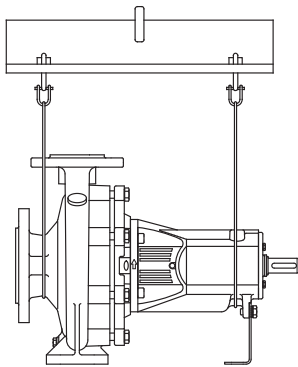

Fig. 1: Transporting the pump

- The bearing capacity of the hoisting gear must be appropriate for the weight of the pump. The pump weight can be found in the catalogue or the data sheet of the pump.
- To avoid deformations, lift up the pump accordingly (Fig. 1) or (Fig. 2). The lifting lugs attached to the pump or motor must not be used to lift the entire unit. They are only meant for transporting the individual components during installation or dismantling.
- Only remove the documents fastened to the pump during installation. Only remove the sealing devices attached to the flanges of the pump during installation in order to prevent any pump contamination.

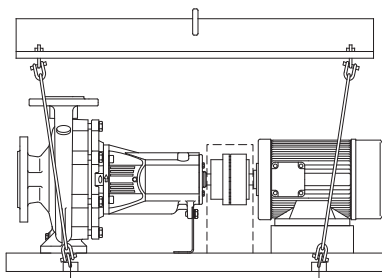

Fig. 2: Transportation of the complete unit

Transport

**DANGER! Risk of fatal injury!**

The pump itself and the pump parts can be extremely heavy. Falling parts pose a risk of cuts, crush injuries, bruises or impacts, which may lead to death.

- Always use suitable lifting equipment and secure parts against falling.
- Never stand beneath a suspended load.
- The safety zone must be marked so that there is no danger when the load (or part of it) slips away or if the hoisting gear snaps or is ripped off.
- Loads must never be suspended for longer than necessary.

Accelerations and braking during the lifting operation must be done so that danger to people is ruled out.

**WARNING! Danger of bodily injury!**

Improper transport can lead to personal injury.

- When lifting machines or parts using lugs, only hooks or shackles can be used which meet the local safety regulations. The holding chains/ropes must never be guided over or through sharp edges without protection.
- When lifting, make sure that the load limit of a rope is reduced when pulling at an angle.
- The safety and efficiency of a rope is best guaranteed when all load-bearing elements are loaded as vertical as possible.
- If necessary, use a lifting arm, to which the attachment rope can be vertically attached.
- If block and tackle or similar hoisting gear is used, vertical lifting of the load must be ensured. The suspended load must be prevented from swinging. This can be achieved, for example, by using a second block and tackle, whereby the relative pulling angle to the vertical must be less than 30° in both cases.

3.3 Removing/replacing corrosion protection (only NL pumps)

The interior parts of the pump are protected by a corrosion-protection film. This must be removed before commissioning. For this, fill and empty the pump several times with a suitable product (e.g. petroleum-based solvent or an alkaline cleaning agent), and rinse with water, if necessary.

**WARNING! Danger of bodily injury!**

Improper handling of solvents or cleaning agents can lead to bodily injuries and environmental damage.

- Take all precautionary measures to avoid risks to personnel and the environment during this operation.
- The pump must be installed and put into operation immediately after this operation.

If the pump is stored for longer than 6 months, the corrosion protection film for protecting the inner parts of the pump must be applied again regularly. Contact the manufacturer with regard to choosing suitable products.

English

4 Intended use

Purpose

The glanded pumps of the Stratos Wilo-CronoNorm-NL/NLG series are intended for use as circulation pumps in building services. The pumps are only to be used for the approved fluids according to section 5.2 "Technical data" on page 62.

Fields of application

The Wilo-CronoNorm NL/NLG pumps may only be used for:

- Hot water heating systems
- Cooling and cold water circulation systems
- Potable water systems (special version)
- Industrial circulation systems
- Heat carrier circuits

Restrictions

Typical installation locations are technical rooms within the building with other domestic installations. No provision has been made for direct installation of the device in rooms used for other purposes (residential and work rooms).

For these series, it is only possible to set them up outdoors in their corresponding, special version (motor with idle heater).



CAUTION! Risk of damage to property!

Impermissible substances in the fluid can destroy the pump.

Abrasive solids (e.g. sand) increase pump wear.

Pumps without an Ex certificate are not suitable for use in potentially explosive areas.

- Intended use of the pump/installation also includes following these instructions.
- Any use above and beyond these is regarded as improper use.

5 Product information

5.1 Type key

The type key of a pump of type Wilo-CronoNorm-NL consists of the following elements:

Example:	NL 40/200B-11/2
NL	Series designation: Standard pump
40	Nominal diameter DN of the pressure port
200	Nominal diameter of the impeller [mm]
B	Hydraulic version
11	Rated motor power P_2 [kW]
2	Number of poles

The type key of a pump of type Wilo-CronoNorm-NLG consists of the following elements:

Example:	NLG 200/315-75/4
NLG	Series designation: Standard pump
200	Nominal diameter DN of the pressure port
315	Nominal diameter of the impeller [mm]
75	Rated motor power P_2 [kW]
4	Number of poles

5.2 Technical data

Property	Value	Remarks
Nominal speed	2900, 1450, 960 rpm	
Nominal diameters, DN	NL: 32 – 150 NLG: 150 – 300	
Permissible min./max. fluid temperature	NL: –20 °C to +120 °C NLG: –20 °C to +120 °C	Design with seal ring classification
Permissible min./max. fluid temperature	NL: –20 °C to +105 °C NLG: –20 °C to +105 °C	Design with stuffing box packing
Max. ambient temperature	+ 40 °C	
Max. permissible operating pressure	16 bar	
Insulation class	F	
Protection class	IP 55	
Flanges	NL: PN 16 in acc. with DIN EN 1092-2 NLG: PN 16 in acc. with ISO 7005-2	
Approved fluids	<ul style="list-style-type: none"> • Heating water according to VDI 2035 • Cooling/cold water • Water/glycol mixture up to 40% vol. • Heat transfer oil • Other fluids (on request) 	<ul style="list-style-type: none"> • Standard version • Standard version • Standard version • Special version or auxiliary equipment (at additional charge) • Special version or auxiliary equipment (at additional charge)
Electrical connection	3~400 V, 50 Hz	Standard version
Special voltages/frequencies	Pumps with motors with different voltages or with other frequencies are available on request.	Special version or auxiliary equipment (at additional charge)
Motor protection	PTC thermistor sensor	

Tab. 1: Technical data

Please state all the information on the pump name plate when ordering spare parts.

Fluids

If water/glycol mixtures with up to 40% glycol (or fluids with viscosities different from pure water) are used, the pump data must be corrected accordingly (depending on the percentage mixture ratio and fluid temperature). The motor power must also be adjusted if necessary.

- Only use mixtures with corrosion inhibitors. The respective manufacturer's instructions are to be observed.
- The fluid must be free of sediments.
- Wilo's approval must be obtained for use of other media.
- Mixtures with a proportion of glycol of > 10% influence the $\Delta p-v$ pump curve and the flow calculation.



NOTE:

The safety data sheet of the pumped fluid must always be observed!

English

5.3 Scope of delivery

The pump can be delivered

- as a complete unit, consisting of the pump, electric motor, baseplate, coupling and coupling protection (but without the motor)
- or

- as a pump with bearing bracket without a baseplate.

Scope of delivery respectively:

- NL/NLG pump
- Installation and operating instructions

5.4 Accessories

Accessories of any kind must be ordered separately.

See catalogue for detailed list.

6 Description and function

6.1 Description of the product

The NL/NLG pump is a single-stage back pull out centrifugal pump with spiral housing, which is sealed by a mechanical seal or a stuffing box packing.

The mechanical seal is maintenance-free.

In conjunction with a Wilo control device (e.g. VR-HVAC, CC-HVAC), the power of the pumps can be continuously controlled. This allows optimisation of the pump output for the demands of the installation and economically efficient pump operation.

The main purpose of the pumps is pumping pure fluids, such as water, in heating, ventilating and air-conditioning systems or in irrigation systems.

6.2 Design set-up

Design:

Single-stage spiral housing pump in process design for horizontal set-up.

NL: Powers and dimensions in acc. with EN 733

NLG: Extension series, not covered by EN 733

The pump consists of a radially divided spiral housing (NLG, additionally with exchangeable stationary wear rings) and cast-on pump bases. The impeller is a closed radial impeller. The pump shaft is supported by grease-lubricated radial ball bearings. The pump is sealed via a mechanical seal in acc. with EN 12756 or by a stuffing box packing.

6.3 Anticipated noise levels for standard pumps

Anticipated noise levels for standard pumps:

Motor power P_N [kW]	Measuring surface sound-pressure level L_p, A [dB(A)] ¹⁾	
	Pump with three-phase motor without speed control	
	2900 min ⁻¹	1450 min ⁻¹
≤ 0.55	52	58
0.75	60	51
1.1	60	53
1.5	67	55
2.2	67	59
3.0	67	59
4.0	67	59
5.5	71	63
7.5	71	63
11	74	65
15	74	65
18.5	74	71
22	76	71
30	79	72
37	79	73
45	79	73
55	79	74
75	80	72
90	81	70
110	81	72
132	-	72
160	-	72
200	-	73
250	-	74
315	-	74

Tab. 2: Anticipated noise levels for standard pumps

¹⁾ Spatial mean value of sound-pressure levels within a cube-shaped measuring area at a distance of 1 m from the surface of the motor

English

6.4 Permissible forces and torques on the pump flanges

Wilo-CronoNorm-NL series

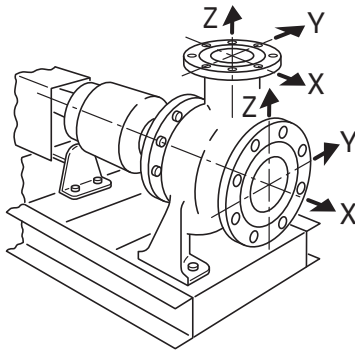

Wilo-CronoNorm-NL series (see Fig. 3 and Tab. 3)

Values in acc. with ISO/DIN 5199 – class II (1997) – Appendix B, Family no. 2

- for installing on the cast frame without concrete casting and a pumping temperature up to 110 °C, or
- for installing on the cast frame with concrete casting and a pumping temperature up to 120 °C.

Fig. 3: Permissible forces and torques on the pump flanges - Wilo-CronoNorm-NL series

	DN	Forces F [N]				Torques M [Nm]			
		F _Y	F _Z	F _X	Σ Forces F	M _Y	M _Z	M _X	Σ Torques M
Pressure port	32	400	500	440	780	360	420	520	760
	40	400	500	440	780	360	420	520	760
	50	540	660	600	1040	400	460	560	820
	65	820	1000	900	1580	460	520	640	940
	80	820	1000	900	1580	460	520	640	940
	100	1080	1340	1200	2100	500	580	700	1040
	125	1620	2000	1800	3140	700	820	1000	1460
	150	1620	2000	1800	3140	700	820	1000	1460
	200	2160	2680	2400	4180	920	1060	1300	1920
	250	2700	3340	2980	5220	1260	1460	1780	2620
Suction port	300	3220	4000	3580	6260	1720	1980	2420	3560
	50	600	540	660	1040	400	460	560	820
	65	900	820	1000	1580	460	520	640	940
	80	900	820	1000	1580	460	520	640	940
	100	1200	1080	1340	2100	500	580	700	1040
	125	1800	1620	2000	3140	700	820	1000	1460
	150	1800	1620	2000	3140	700	820	1000	1460
	200	2400	2160	2680	4180	920	1060	1300	1920
	250	2980	2700	3340	5220	1260	1460	1780	2620
	300	3580	3220	4000	6260	1720	1980	2420	3560
350	4180	3760	4660	7300	2200	2540	3100	4560	

Tab. 3: Permissible forces and torques on the pump flanges – Wilo-CronoNorm-NL series

Wilo-CronoNorm-NLG series

Wilo-CronoNorm-NLG series (see Fig. 4 and Tab. 4)

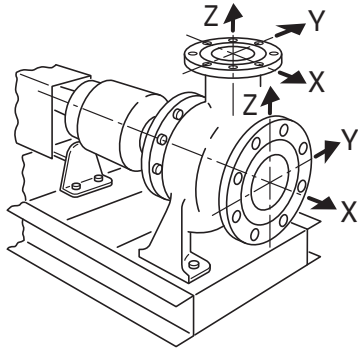

Values in acc. with ISO/DIN 5199 – class II (1997) – Appendix B, Family no. 2

- for installing on the cast frame without concrete casting and a pumping temperature up to 110 °C, or
- for installing on the cast frame with concrete casting and a pumping temperature up to 120 °C.

Fig. 4: Permissible forces and torques on the pump flanges - Wilo-CronoNorm-NLG series

	DN	Forces F [N]				Torques M [Nm]			
		F _Y	F _Z	F _X	Σ Forces F	M _Y	M _Z	M _X	Σ Torques M
Pressure port	150	2050	3110	2490	4480	1180	1760	2300	3127
	200	3110	4890	3780	6919	1760	2580	3560	4736
	250	4450	6670	5340	9634	2440	3800	5020	6752
	300	5340	8000	6670	11705	2980	4610	6100	8206
	350	5780	8900	7120	12779	3120	4750	6370	8537
	400	6670	10230	8450	14851	3660	5420	7320	9816
Suction port	200	3780	3110	4890	6919	1760	2580	3530	4713
	250	5340	4450	6670	9634	2440	3800	5020	6752
	300	6670	5340	8000	11705	2980	4610	6100	8206
	350	7120	5780	8900	12779	3120	4750	6370	8537
	400	8450	6670	10230	14851	3660	5420	7320	9816
	450	9120	7220	10920	15955	4150	5960	7720	10599

Tab. 4: Permissible forces and torques on the pump flanges - Wilo-CronoNorm-NLG series

English

7 Installation and electrical connection

Safety



DANGER! Risk of fatal injury!

Improper installation and electrical connection can result in fatal injury.

- Have the electrical connections established by licensed electricians only, in compliance with the applicable regulations.
- Accident prevention regulations must be observed!



DANGER! Risk of fatal injury!

Failure to install safety devices on the motor, terminal box or on the coupling can cause electrical shock or contact with rotating parts, potentially resulting in life-threatening injuries.

- Before commissioning, all safety devices (such as terminal box covers or coupling covers) that were removed before must be reinstalled.



DANGER! Risk of fatal injury!

The pump itself and the pump parts can be extremely heavy. Falling parts pose a risk of cuts, crushing injuries, bruises or impacts, which may lead to death.

- Always use suitable lifting equipment and secure parts against falling.
- Never stand beneath a suspended load.



CAUTION! Risk of damage to property!

Danger of damage due to improper handling.

- Have the pump installed by qualified personnel only.



CAUTION! Damage to the pump due to overheating!

Never allow the pump to run dry. Dry running can damage the pump, particularly the mechanical seal or the stuffing box packing.

- Make sure that the pump never runs dry.

7.1 Preparation



CAUTION! Risk of injury and damage to property!

Danger of damage due to improper handling.

- Never set up the pump unit on unfortified surfaces or surfaces which cannot bear loads.
- Install only after completion of all welding and soldering work and after the pipe system has been flushed, if required. Dirt can cause pump failure.
- The pumps (in the standard version) must be protected from the weather and installed in a frost/dust-free, well-ventilated environment which is not potentially explosive.
- Install the pump in a place that is easy to access so that later inspections, maintenance (e.g. exchanging the mechanical seal) or replacement is easily possible.
- A travelling crane or a device for attaching hoisting gear should be installed above the set-up site of large pumps.

7.2 Setting up the pump alone (variant B, according to Wilo variant key)

7.2.1 General

When installing a pump by itself (variant B, according to the Wilo variant key), the required components (coupling, coupling protection and baseplate of the manufacturer) should be used.

In any case, all components must meet the CE regulations. The coupling protection must be compatible with EN 953.

7.2.2 Motor selection

- Motor and coupling must be CE compliant.
- Select a motor with sufficient power (see Tab. 5).

Shaft power	< 4 kW	4 kW < P ₂ < 10 kW	10 kW < P ₂ < 40 kW	40 kW < P ₂
Limit value for the P ₂ motor	25 %	20 %	15 %	10 %

Tab. 5: Motor/shaft power

Example:

- Water duty point:
Q = 100 m³/h
H = 35 m
Efficiency = 78 %
- Hydraulic power:
12.5 kW

The required limit value for this duty point lies at 12.5 kW x 1.15 = 14.3 kW

A motor with a power of 15 kW would be the correct choice.

Wilo recommends using a B3 motor (IM1001) with base installation, which is compatible with IEC34-1.

7.2.3 Coupling selection

- To establish the connection between the pump with bearing bracket and motor, use a flexible coupling.
- Select the coupling size according to the recommendations of the coupling manufacturer.
- Follow the instructions of the coupling manufacturer.
- After installation on the base and connecting the lines, the coupling alignment must be checked and corrected, if necessary. See also section 7.5.2 "Check the coupling alignment" on page 71.
- After reaching the operating temperature, the coupling alignment must be checked again. The coupling must be protected in acc. with EN 953 to prevent accidental contact during operation.

7.3 Installation on a base of the pump unit



CAUTION! Danger of property and material damage!

A flawed base or an incorrect installation of the unit on the base can lead to a malfunction of the pump; this is not covered by the warranty.

- Only have the pump unit installed by skilled personnel.
- A professional from the concrete area must be hired for all base work.

7.3.1 Base

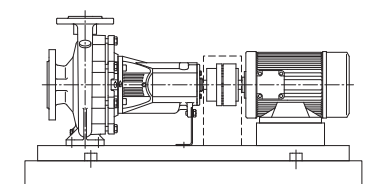

Fig. 5: Installing the pump on a base

Wilo recommends installing the pump unit on a stable, flat concrete base, which can support the unit long-term (see Fig. 5). This would prevent vibrations from being transmitted.

The base, made of non-shrinking mortar, must be able to accommodate the forces, vibrations and impacts which occur during operation of the pump unit. The base should be approx. 1.5 to 2x heavier than the unit (guide value). The width and length of the base should each be about 200 mm greater than the baseplate.

7.3.2 Preparing the baseplate for anchoring

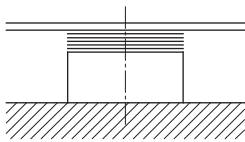

Fig. 6: Shims on the base surface

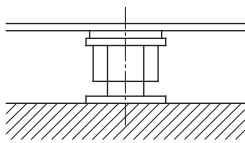

Fig. 7: Levelling screws on the base surface

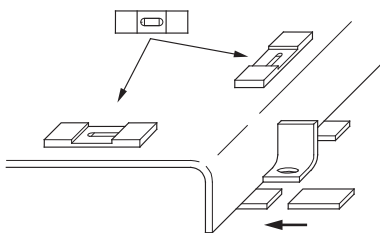

Fig. 8: Levelling and aligning the baseplate

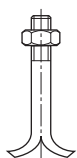

Fig. 9: Anchor bolts

The baseplate must be mounted on a firm base, which must be made of high-quality concrete of sufficient thickness. The baseplate must NOT be strained or pulled down on the surface of the base, but must be supported so that the original alignment isn't changed.

Drilled holes for the anchor bolts must be provided in the base using pipe sleeves. The diameter of the pipe sleeves is equivalent to about 2 ½ times the diameter of the screws, so that these can be moved to reach their final positions.

Wilo recommends initially pouring the base up to about 25 mm below the planned height. The surface of the concrete base should be well contoured before curing. Remove the pipe sleeves after the concrete cures.

If it is planned to pour out the baseplate, then a sufficient number of steel rods (depending on the size of the baseplate) should be placed evenly distributed in the base. The rods should project into the baseplate by up to $\frac{2}{3}$.

- Thoroughly clean the base surface.
 - Place shims (approx. 20–25 mm thick) on every screw hole on the base surface (see Fig. 6). Alternatively, levelling screws can also be used (see Fig. 7).
 - For a length spacing of the fastening bores ≥ 800 mm, shims should be additionally placed in the middle of the baseplate.
 - Apply the baseplate and level this in both directions with additional shims (see Fig. 8).
 - Align the complete unit when installing on the base using a spirit level (at the shaft/pressure port) (see Fig. 8). The baseplate should be horizontal with a tolerance of 0.5 mm per meter.
 - Fit anchor bolts (see Fig. 9) in the provided drilled holes.
- NOTE:**
The anchor bolts must fit in the fastening bores of the baseplate. They must meet the relevant standards and be sufficiently long, so that a firm fit in the base is guaranteed.
- Pour in anchor bolts with concrete. After the concrete has set, the anchor bolts can be evenly and firmly tightened.
 - Align the unit so that the pipes can be connected to the pump stress-free.



7.3.3 Pouring out the baseplate

- If vibrations are to be reduced to a minimum, after fastening, the baseplate can be poured out with a non-shrinking mortar over its openings (the mortar must be suitable for installation on a base). Hollow spaces are to be avoided. The concrete surface must be moistened beforehand.
- The base/baseplate is to be planked.
- After curing, the anchor bolts are to be checked for a tight fit.
- The unprotected surfaces of the base are to be protected against moisture with a suitable coating.

7.4 Pipework

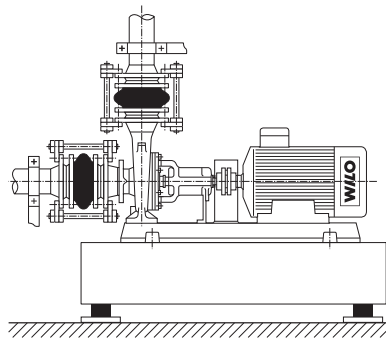

Fig. 10: Connecting the pump stress-free



CAUTION! Risk of damage to property!

Improper pipework/installation can lead to property damage.

- The pipe connections of the pump are provided with protective caps so that no foreign objects can penetrate during transport and installation. These caps must be removed before connecting pipes.
- Welding beads, cinder and other contaminants can damage the pump.
- The pipes must be sufficiently dimensioned, taking the pump inlet pressure into account.
- The pump and pipes are to be connected using suitable seals, taking the pressure, temperature and fluid into account. Make sure the seals are correctly fit.
- The pipes must not transfer any forces to the pump. They are to be braced directly in front of the pump and connected without tension (see Fig. 10).
- The permissible forces and torques on the pump connecting piece are to be observed (see section 6.4 "Permissible forces and torques on the pump flanges" on page 65).
- The expansion of the pipes in the event of a temperature rise is to be compensated by suitable means (see Fig. 10). Air enclosures in the pipes must be avoided by means of a corresponding installation.



NOTE:

The installation of return flow inhibitors and check valves is recommended. This allows the pump to be drained and maintained without having to drain the entire system.



NOTE:

A settling section must be provided before and after the pump, in the form of a straight pipe. The length of this settling section should be at least 5 x DN of the pump flange. This measure serves to avoid flow cavitation.

- The pipes and pump must be free of mechanical stress when installed. The pipes must be fastened in such a way that the pump does not bear the weight of the pipes.
- Before connecting the pipes, the system must be cleaned, flushed and blown through.
- The covers must be removed from the suction port and discharge port.
- If required, a dirt filter is to be inserted in front of the pump in the pipe on the suction side.
- Then connect the pipes to the pump connecting piece.

English

7.5 Aligning the unit

7.5.1 General



CAUTION! Danger of property and material damage!
Improper handling can lead to property and material damage.

- The alignment must be checked before the first start. The transport and installation of the pump can affect the alignment. The motor must be aligned to the pump (and not vice versa).
- The pump and motor are usually aligned at ambient temperature. They may have to be readjusted so that the thermally related expansion at the operating temperature is taken into account. If the pump has to pump very hot fluids, proceed as follows: Allow the pump to run at the actual operating temperature. Switch off pump, then immediately check the alignment.

Precondition for reliable, smooth and efficient operation of a pump unit is proper alignment of the pump and the drive shaft. Misalignments can be the cause of:

- excessive noise development during pump operation
- vibrations
- premature bearing wear
- excessive coupling wear

7.5.2 Check the coupling alignment

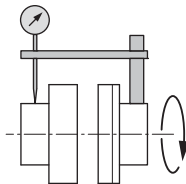

Fig. 11: Checking the radial alignment with a comparator



Check the radial alignment:

- Firmly clamp a dial gauge to one of the couplings or to the shaft (see Fig. 11). The piston of the dial gauge must lie against the crown of the other half-coupling (see Fig. 11).
- Set the dial gauge to zero.
- Turn the coupling and write down the measuring result after every quarter turn.
- Alternatively, the radial coupling alignment can also be checked with a ruler (see Fig. 12).

NOTE:

The radial deviation of the two coupling halves may be a max. of 0.15 mm in every state, i.e. even at the operating temperature and when inlet pressure is applied.

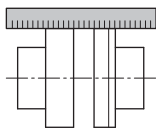

Fig. 12: Checking the radial alignment with a ruler

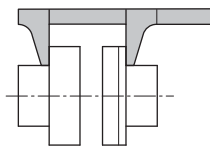

Fig. 13: Checking the axial alignment with a calliper gauge

Check the axial alignment:

Using a calliper gauge, circumferentially check the distance between the two coupling halves (see Fig. 13 and Fig. 14).

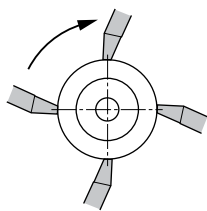

Fig. 14: Checking the axial alignment with a calliper gauge - circumferential check



NOTE:

The axial deviation of the two coupling halves may be a max. of 0.1 mm in every state, i.e. even at the operating temperature and when inlet pressure is applied.

- When correctly aligned, connect the coupling halves and mount the coupling protection. The tightening torques of the coupling are listed in Tab. 6.

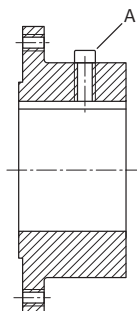

Fig. 15: Set screw A for axial safeguard

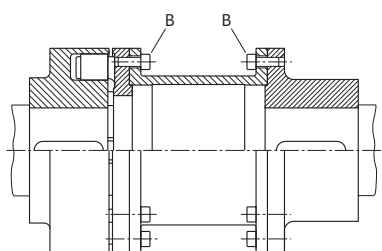

Fig. 16: Fastening screws B of coupling halves

Tightening torques for set screws and coupling halves
(see also Fig. 15 and Fig. 16):

Coupling parameter d [mm]	Tightening torque, set screw A [Nm]	Tightening torque, set screw B [Nm]
80, 88, 95, 103	4	13
110, 118	4	14
125, 135	8	17.5
140, 152	8	29
160, 172	15	35
180, 194	25	44
200, 218	25	67.5
225, 245	25	86
250, 272	70	145
280, 315	70	185
350, 380	130	200
400, 430	130	340
440, 472	230	410

Tab. 6: Tightening torque for set screws and coupling halves

7.5.3 Alignment of the pump unit

All deviations in the measuring results indicate a misalignment. In this case, the unit must be realigned to the motor.

- To do this, loosen the hexagon head bolts and the counter nuts on the motor.
- Place shims under the motor feet until the height difference is compensated. Pay attention to the axial alignment of the coupling.
- Tighten the hexagon head bolts again.
- Finally, check the function of the coupling and shaft. The coupling and shaft must be easy to turn by hand.
- After correct alignment, mount the coupling protection.

- The tightening torques for the pump and motor on the baseplate are listed in Tab. 7.

Screw:	M8	M10	M12	M16	M20	M24	M30	M36
Tightening torque [Nm]	12	25	40	90	175	300	500	700

Tab. 7: Tightening torques for pump and motor

7.6 Electrical connection

7.6.1 Safety



DANGER! Risk of fatal injury!

A fatal shock may occur if the electrical connection is not made correctly.

- Only allow the electrical connection to be made by an electrician approved by the local power supply company and in accordance with the local regulations in force.
- Before beginning work on the product, make sure that the pump and drive are electrically isolated.
- Make sure that no one can turn on the power supply again before ending work.
- Make sure that all energy sources can be isolated and locked. If the machine was switched off by a protective device, it must be made sure that it can't be switched on again before the error has been remedied.
- Electrical machines must always be earthed. Earthing must be appropriate for the motor and meet the relevant standards and regulations. This also applies to selecting the right size of the earthing terminals and fastening elements.
- Under no circumstances may connecting cables touch the pipe, the pump or the motor housing.
- If it is possible that people can come in contact with the machine and the pumped fluid (for example, on building sites), the earthed connection must be additionally equipped with a residual current circuit breaker.
- Observe the installation and operating instructions for the accessories!
- During installation and connection work, observe the circuit diagram in the terminal box!



CAUTION! Risk of damage to property!

If the electrical connection is done improperly, there is a danger of damage to the product.

- The installation and operating instructions must be observed for electrical connection of the motor.
- The current type and voltage of the mains connection must agree with the specifications on the rating plate.

7.6.2 Procedure



NOTE:

All three-phase motors are equipped with a thermistor. Wiring information can be found in the terminal box.

- Establish the electrical connection via a stationary power cable.
- When pumps are used in systems with water temperatures above 90 °C, a suitably heat-resistant power cable must be used.
- In order to ensure drip protection and strain relief on the cable connections, cables with a suitable outer diameter must be used and the cable feedthroughs firmly screwed. Furthermore, cables must be bent off to form outlet loops near screwed connections to avoid the accumulation of drip water.

- Unused cable feedthroughs should be sealed with the sealing plates provided, and screwed tight.

**NOTE:**

The direction of rotation of the motor must be checked in the course of commissioning.

7.7 Protective devices**WARNING! Danger of burns!**

The spiral housing and the pressure cover assume the temperature of the fluid during operation.

- Depending on the application, insulate the spiral housing if necessary.
- Provide corresponding contact protection. The local regulations must be complied with.
- Observe the terminal box!

**CAUTION! Risk of damage to property!**

The pressure cover and the bearing bracket must not be insulated.

8 Commissioning / decommissioning**8.1 Safety****WARNING! Danger of bodily injury!**

Injuries can occur due to missing protective equipment.

- The unit casings of moving parts (such as of the coupling) may not be removed during machine operation.
- Always wear protective clothing, protective gloves and protective goggles when working.
- The safety devices on the pump and motor must not be removed or disabled. They must be checked by an appropriately authorized technician for proper function before commissioning.

**CAUTION! Risk of damage to property!**

Due to improper operation, there is a danger of damaging the pump.

- The pump must not be operated outside of the specified operating range. Operating outside of the duty point can impair the pump efficiency or damage the pump. Operating with the valve closed for more than 5 minutes is not recommended. We generally advise against hot fluids.
- Make sure that the NPSH-A value is always higher than the NPSH-R value.

**CAUTION! Risk of damage to property!**

When using the pump in air-conditioning or cooling applications, condensate can form, which could damage the motor.

- To avoid motor damage, the condensate drainage holes in the motor housing must be opened regularly and the condensate drained.

8.2 Filling and bleeding**NOTE:**

Pumps of the NL series do not have a bleed valve. The suction line and pump are bled via a suitable bleeding device on the pressure side of the pump.

**WARNING! Risk of injury and damage to property!**

Danger due to extremely hot or extremely cold pressurised fluid!

Depending on the temperature of the fluid and the system pressure, when the venting screw is opened completely, extremely hot or extremely cold fluid in liquid or vapour form may escape or shoot out at high pressure.

- Make sure the venting screw is in a suitable position.
- Always exercise caution when opening the venting screw.

Procedure for systems where the fluid level lies above the suction port of the pump:

- Open the check valve on the pressure side of the pump.
- Slowly open the check valve on the suction side of the pump.
- To bleed, open the venting screw on the pressure side of the pump or on the pump.
- Close the venting screw as soon as fluid escapes.

Procedure for systems with a non-return valve, where the fluid level lies below the suction port of the pump:

- Close the check valve on the pressure side of the pump.
- Open the check valve on the suction side of the pump.
- Fill fluid in via a funnel until the suction line and the pump are completely filled.

8.3 Checking the direction of rotation



**CAUTION! Risk of damage to property!
Risk of damaging the pump.**

- **Before checking the direction of rotation and commissioning, the pump must be filled with fluid and bled. During operation, never close the check valves in the suction line.**

The correct direction of rotation is indicated by an arrow on the pump housing. As seen from the motor side, the pump rotates correctly in the clockwise direction.

- To check the direction of rotation, disengage the pump from the coupling.
- To check the motor, only switch on briefly. The direction of rotation of the motor must correspond to the direction of rotation arrow on the pump. If the direction of rotation is wrong, the electric connection of the motor should be changed accordingly.
- After checking the direction of rotation, connect the pump to the motor, check the coupling alignment and, if required, realign.
- Finally, remount the coupling protection.

8.4 Switching on the pump



**CAUTION! Risk of damage to property!
Danger of damage of those pump parts, the lubrication of which depends on the fluid supply.**

- **The pump must not be switched on when the check valves are closed in the suction and/or pressure pipe.**
- **The pump may only be operated within the permissible operating range.**

After the centrifugal pump has been properly installed and also, when aligning to the drive, all required precautionary measures have been taken, the pump is ready for starting.

- Before starting the pump, it must be checked whether the following preconditions have been met on the pump:
 - Filling and venting lines are closed.
 - The bearings are filled with the right amount of lubricant of the right type (if applicable).
 - The motor is turning in the right direction.
 - The coupling protection is attached correctly and is screwed tightly.
 - Pressure gauges with a suitable measuring range are installed on the suction and pressure side of the pump. The pressure gauges must not be installed at bends of the piping, where the measurements could be influenced by the kinetic energy of the fluid.
 - All blind flanges are removed and the check valve on the suction side of the pump is completely opened.
 - The check valve in the pressure pipe of the pump is completely closed or only slightly opened.



WARNING! Danger of bodily injury!
Danger due to high system pressure.

- Do not connect pressure gauges to a pressurised pump.
- The power and status of the installed centrifugal pumps must be constantly monitored. Pressure gauges are to be installed on the suction side and on the pressure side.



NOTE:

It is recommended to install a flow meter, since otherwise the pump delivery rate cannot be exactly determined.



CAUTION! Risk of damage to property!
Danger of overloading the motor.

- To start up the pump, use the soft start, star-delta switching or speed control.
- Switch on the pump.
- After reaching the speed, slowly open the check valve in the pressure pipe and regulate the pump to the duty point.
- While the pump is starting, bleed completely via the venting screw.



CAUTION! Risk of damage to property!
Risk of damaging the pump.

- If abnormal noises, vibrations, temperatures or leaks occur during starting, the pump must be switched off immediately and the cause remedied.

8.5 Leak check

Mechanical seal:

The mechanical seal is maintenance-free and usually has no visible leakage losses.

Stuffing box packing:



WARNING! Danger of bodily injury!

Work on the stuffing box packing is done while the pump is running, and must be done with extreme caution.

The stuffing box packing drips slightly during operation. The leakage rate should be between 10 and 20 cm³/min. Before commissioning, the stuffing box gland is only slightly tightened.

- After an operating time of 5 minutes, reduce excessively high leakage by evenly tightening the nuts by approx. 1/6 turn.
- After another 5 minutes, check the leakage rate. Repeat this process until the recommended leakage rate is set.
- If the leakage rate is too low, increase it by loosening the nuts.
- Watch the leakage during the first couple operating hours at the maximum fluid temperature. At the least amount of delivery pressure, there must be sufficient leakage.

English

8.6 Switch-on frequency



CAUTION! Risk of damage to property!
Risk of damaging the pump or the motor.

- Only switch on the pump again when it is at a standstill.

The switch-on frequency is determined by the maximum temperature increase of the motor. It is recommended that repeated activations occur at regular intervals. Under this precondition, the following guide values apply (see Tab. 8):

Motor power [kW]	Max. switchings per hour
< 15	15
< 110	10
> 110	5

Tab. 8: Guide values for switchings per hour

8.7 Switching off the pump and temporary shutdown



CAUTION! Risk of damage to property!
Danger of damage to the pump seals due to high fluid temperature.

- When pumping hot fluids, the pump must have a sufficient run-on time after the heating source has been switched off.



CAUTION! Risk of damage to property!
Risk of damaging the pump due to frost.

- If there is a danger of frost, the pump is to be completely drained to avoid damage.
- Close the check valve in the pressure pipe.



NOTE:
Do **not** close the check valve in the suction line.

- Switch off the motor.
- If a non-return valve is installed in the pressure pipe, and there is counter pressure, the check valve can remain open.
- As far as there is no danger of frost, make sure the fluid level is sufficient. Operate the pump every month for 5 minutes. This way, deposits are avoided in the pump space.

8.8 Decommissioning and storage



WARNING! Risk of injury and damage to property!

- The pump contents and rinsing fluid are to be disposed of taking the legal regulations into account.
- Always wear protective clothing, protective gloves and protective goggles when working.
- Before storage, thoroughly clean the pump, especially of high-risk fluids. To do this, completely drain the pump and rinse. The remaining fluid and rinsing fluid are to be drained, collected and disposed of via the drain plug.
- The interior of the pump is to be sprayed with a preservative through the suction and pressure ports. Wilo recommends sealing the suction and pressure ports using caps afterwards.
- Bare components are to be greased or oiled. For this, use silicone-free grease or oil. Observe the manufacturer instructions for preservatives.

9 Maintenance/repair

9.1 Safety

Only have maintenance and repair work carried out by qualified personnel!

It is recommended to have the pump serviced and checked by Wilo Customer Service.



DANGER! Risk of fatal injury!

Deadly electric shock may occur when working on electrical equipment.

- Work on electrical equipment may only be done by electricians approved by the local electricity supplier.
- Before working on electrical equipment, switch it off and prevent it from being switched on again.
- Any damage to the connecting cable should always be rectified by a qualified electrician only.
- Follow the installation and operating instructions for the pump and other accessories.



DANGER! Risk of fatal injury!

Failure to install safety devices on the motor, terminal box or on the coupling can cause electrical shock or contact with rotating parts, potentially resulting in life-threatening injuries.

- After maintenance, all safety devices (such as module and fan covers) that were removed, e.g. the terminal box cover and coupling protection, must be reinstalled!



DANGER! Risk of fatal injury!

The pump itself and the pump parts can be extremely heavy. Falling parts pose a risk of cuts, crushing injuries, bruises or impacts, which may lead to death.

- Always use suitable lifting equipment and secure parts against falling.
- Never stand beneath a suspended load.
- Make sure the pump is securely positioned and is stable during storage and transport as well as prior to all installation and other assembly work.



DANGER! Danger of bodily injury!

Danger of burns or freezing to the pump when body parts come into contact with the pump! Depending on the pump or system operating conditions (fluid temperature), the entire pump can become very hot or very cold.



- Keep a safe distance during operation!
- In the case of high water temperatures and system pressures, allow the pump to cool down before all work.
- Always wear protective clothing, protective gloves and protective goggles when working.



DANGER! Risk of fatal injury!

The tools used during maintenance work on the motor shaft (such as an open-end wrench) can be flung out if they come into contact with rotating parts and cause serious or even fatal injuries.

- The tools used during maintenance work must be removed completely before the pump is started up.

- 9.2 Operation monitoring
-  **WARNING! Risk of injury and damage to property!**
- When draining, particularly hot fluids or fluids which are harmful to health, take measures to protect personnel and the environment, for example the use of protective clothing, protective gloves and protective goggles.
 - Pumps which pump hazardous fluids must be decontaminated.
-  **CAUTION! Risk of damage to property!**
Risk of damaging the pump or the motor due to an unsuitable operating mode.
- Do not allow the pump to run without fluid.
 - Do not operate the pump with the check valve in the suction line closed.
 - Do not operate the pump for a longer period of time with the check valve in the pressure pipe closed. This can cause the fluid to overheat.
- The pump must run quietly and vibration-free at all times.
The roller bearings must run quietly and vibration-free at all times. Increased current consumption with unchanged operating conditions is a sign of bearing damage. The bearing temperature may be up to 50 °C above the ambient temperature, but never rise above 80 °C.
- Check the static gaskets and the shaft seal regularly for leaks.
 - For pumps with mechanical seals, there is little to no visible leakage during operation. If there is considerable leakage at the gasket, this means that the gasket surfaces are worn and that the gasket has to be replaced. The service life of a mechanical seal greatly depends on the operating conditions (temperature, pressure, fluid properties).
 - For pumps with a stuffing box packing, make sure the drip leakage is sufficient (approx. 20 – 40 drops per minute). The nuts of the stuffing box gland should only be slightly tightened. If there is excessive stuffing box leakage, further tighten the nuts of the stuffing box gland slowly and evenly until the leakage is reduced to single drops. Check the stuffing box for overheating by hand. If the nuts of the stuffing box gland cannot be further tightened, replace the old packing rings.
 - Wilo recommends checking the flexible coupling elements regularly and replacing them at the first sign of wear.
 - Wilo recommends briefly putting the standby pumps into operation at least once a week to ensure they are always ready for operation.
- 9.3 Maintenance work
- The bearing bracket of the pump is equipped with roller bearings which have lifetime lubrication.
- The roller bearings of the motors are to be maintained according to the installation and operating instructions of the motor manufacturer.
- 9.4 Draining and cleaning
-  **WARNING! Risk of injury and damage to property!**
- Remaining fluid and rinsing fluid is to be collected and disposed of.
 - The disposal of the harmful fluids must be done in accordance with the legal regulations.
 - For all work, wear protective clothing, a protective mask, protective gloves and protective goggles.

9.5 Dismantling

9.5.1 General



DANGER! Risk of fatal injury!

Risk of fatal injury and risk of injuries to personnel and property damage due to improper handling.

- The safety instructions and regulations according to chapter 2 "Safety" on page 55 and section 9.1 "Safety" on page 78 are to be taken into consideration for all maintenance and repair work.

Maintenance and repair work require the pump be partially or completely dismantled.

The pump housing can be installed in the piping.

- Close all valves in the suction line and pressure pipe.
- Drain the pump by opening the drainage screw and the venting screw.
- Switch off the energy supply to the pump and secure against switching on again.
- Remove coupling protection.
- If present: Remove the intermediate sleeve of the coupling.

Motor:

- Remove the fastening screws of the motor from the baseplate.



NOTE:

For installation work, please also observe the sectional drawings in section 11.1 "Spare parts lists, Wilo-CronoNorm-NL" on page 93 as well as in section 11.2 "Spare parts lists, Wilo-CronoNorm-NLG" on page 97.

9.5.2 Dismantling the Wilo-CronoNorm-NL

Slide-in unit

Slide-in unit:

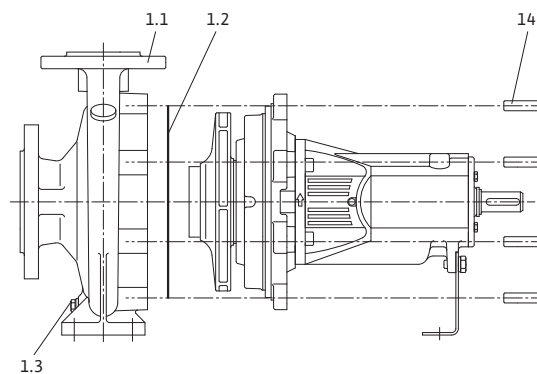

Fig. 17: Slide-in unit

See Fig. 17

- Mark positions of the parts which belong together with a coloured pen or scriber.
- Remove the hexagon head bolts (14).
- Pull the pull-out slide-in unit straight out of the spiral housing (1.1) to avoid damage to interior parts.
- Put the slide-in unit down at a safe workplace. This assembly must be removed vertically to avoid damage to the impellers, stationary wear rings and other parts.
- Remove the housing seal (1.2).

English

See Fig. 18:

- Remove the hexagon head bolts (7.2) and remove the protective screen (7.1).
- Loosen the impeller nut (2.2).
- Remove the impeller (2.1) and key (3.2).

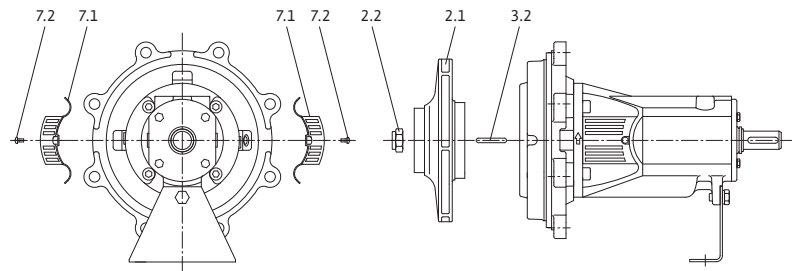

Fig. 18: Slide-in unit

Version with mechanical seal

Version with mechanical seal:

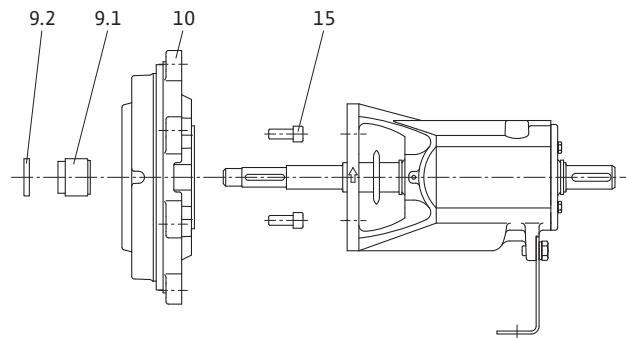

Fig. 19: Version with mechanical seal

See Fig. 19:

- Remove the spacer ring (9.2).
- Remove the rotating part of the mechanical seal (9.1).
- Loosen the internal hexagon head bolts (15) and remove the housing cover (10).

See Fig. 20:

- Remove the stationary part of the mechanical seal (9.1).

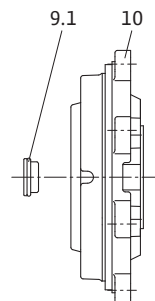

Fig. 20: Housing cover, mechanical seal

Version with stuffing box packing

Version with stuffing box packing:

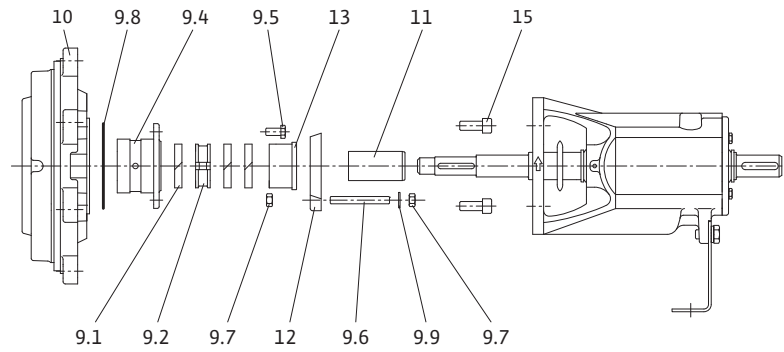

Fig. 21: Version with stuffing box packing

See Fig. 21:

- Loosen the internal hexagon head bolts (15) and remove the housing cover (10).
- Remove the hex nuts (9.7) and bolts (9.6).
- Loosen the hexagon head bolts (9.5) and the stuffing box housing (9.4) with stuffing box gland (12) and stuffing box sleeve (13).
- Remove the seal (9.8) and housing cover (10).
- Remove packing rings (9.1) and blocking ring (9.2).
- Remove the shaft sleeve (11).

Bearing bracket

Bearing bracket:

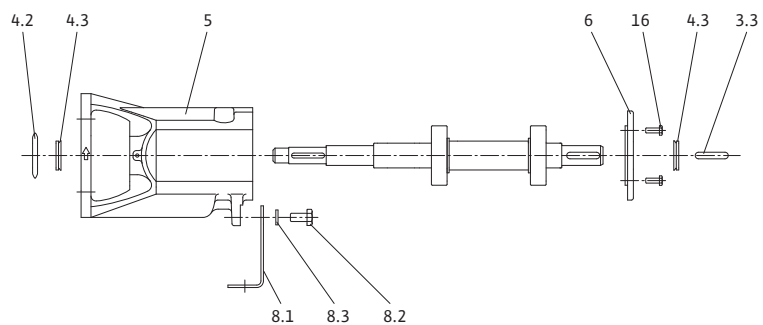

Fig. 22: Bearing bracket

See Fig. 22:

- Remove the key (3.3).
- Loosen the hexagon head bolts (16), remove the V seals (4.3) and remove bearing cover (6).
- Loosen the thrower (4.2).
- Loosen the hexagon screw (8.2), remove the safety disk (8.3) and remove the pump base (8.1).

See Fig. 23:

- Completely remove the shaft (3.1).
- Remove the roller bearings (4.1A and 4.1B) with the support disks (4.4), if applicable.

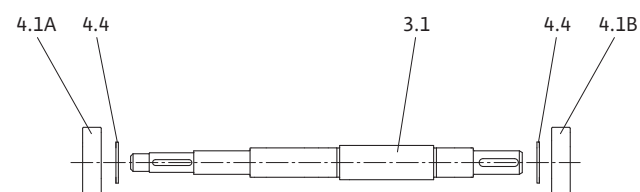

Fig. 23: Shaft

English

9.5.3 Dismantling the Wilo-CronoNorm-NLG



NOTE:
For installation work, please also observe the sectional drawings in section 11.2 "Spare parts lists, Wilo-CronoNorm-NLG" on page 97.

Slide-in unit

Slide-in unit:

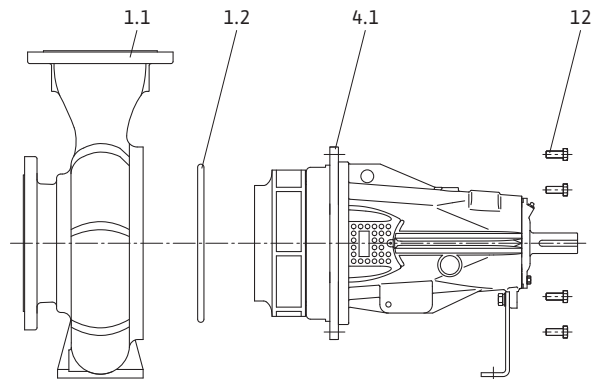

Fig. 24: Slide-in unit

See Fig. 24:

- Mark positions of the parts which belong together with a coloured pen or scribe.
- Remove the hexagon head bolts (12) (connection of housing cover (4.1) and spiral housing (1.1)).
- Pull the pull-out slide-in unit straight out of the spiral housing (1.1) to avoid damage to interior parts.
- Put the slide-in unit down at a safe workplace. This assembly must be removed vertically to avoid damage to the impellers, stationary wear rings and other parts.
- Remove the O-ring (1.2).

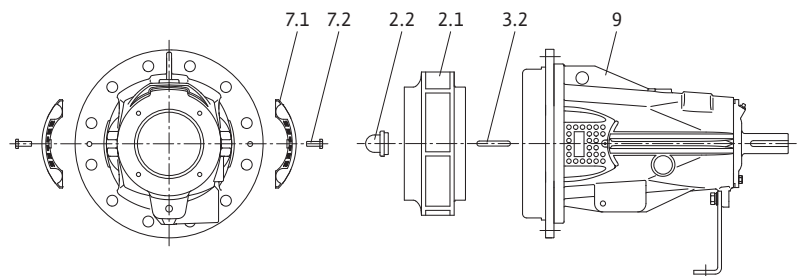

Fig. 25: Slide-in unit

See Fig. 25:

- Remove the hexagon head bolts (7.2) and remove the protective screen (7.1).
- Loosen the impeller nut (2.2).
- Remove the impeller (2.1) and key (3.2).

Version with mechanical seal

Version with mechanical seal:

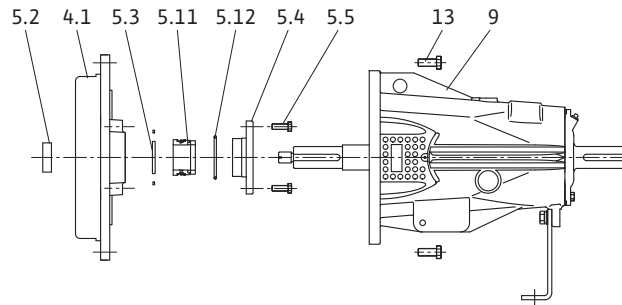

Fig. 26: Version with mechanical seal

See Fig. 26:

- Remove the spacer ring (5.2).
- Remove the hexagon head bolts (5.5) (connection of housing cover (4.1) and mechanical seal cover (5.4)).
- Loosen the hexagon head bolts (13) and remove the housing cover (4.1) from the bearing bracket (9).
- Remove the O-ring (5.12) from the mechanical seal cover (5.4).
- Remove the fixing ring (5.3) from the shaft.
- Pull the mechanical seal (5.11) and mechanical seal cover (5.4) from the shaft.

Version with stuffing box packing

Version with stuffing box packing:

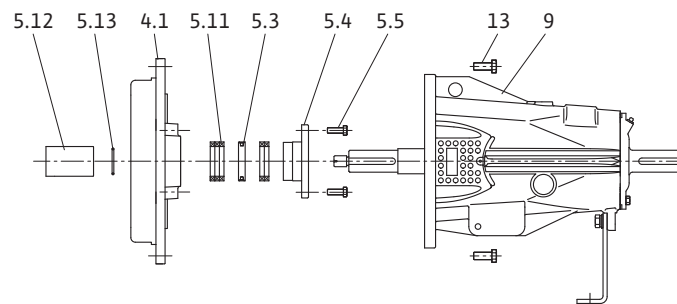

Fig. 27: Version with stuffing box packing

See Fig. 27:

- Loosen the hexagon head bolts (13) and pull the housing cover (4.1) with the stuffing box packing and stuffing box gland from the shaft.
- Loosen the hexagon head bolts (5.5) and remove the stuffing box gland (5.4).
- Remove packing rings (5.11) and blocking ring (5.3).
- Remove the shaft sleeve (5.12), and take the interior O-ring (5.13) out of the shaft sleeve.

English

Bearing bracket

Bearing bracket:

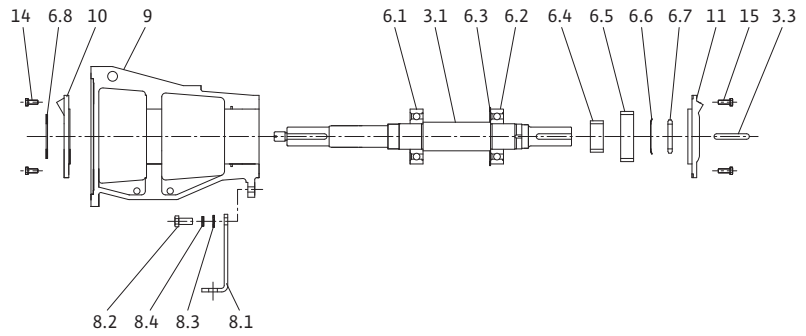

Fig. 28: Bearing bracket

See Fig. 28:

- Remove the pump base (8.1) by loosening the hexagon screw (8.2).
- Remove the key (3.3).
- Loosen the hexagon head bolts (15) and remove the bearing cover (11) on the motor side.
- Remove the thrower (6.8).
- Loosen the hexagon head bolts (14) and remove the bearing cover (10) on the pump side.
- Pull the shaft (3.1) part-way out of the bearing bracket.
- If present, pull off the exterior spacer ring (6.5).
- Loosen the lock nut (6.7) and remove the spring disk (6.6).
- If present, pull off the interior spacer ring (6.4).
- Pull the shaft (3.1) part-way out of the bearing bracket until the circlip (6.3) is accessible.
- Remove the circlip (6.3) using circlip pliers.
- Remove the shaft (3.1) completely out of the bearing bracket.
- Pull the bearings (6.1 and 6.2) off of the shaft.

Stationary wear rings:

The Wilo-CronoNorm-NLG is standard-equipped with exchangeable stationary wear rings. During operation, the gap backlash increases due to wear. The period of use of the rings depends on the operating conditions. The decreasing volume flow and increasing current consumption of the motor in the course of operation could be caused by an impermissibly high gap backlash. In this case, exchange the stationary wear rings.

9.6 Installation

General

Installation must be done based on the detailed drawings in section 9.5 "Dismantling" on page 80 as well as the general drawings in section 11 "Spare parts" on page 92.

Check O-rings for damage and replace them, if necessary. Flat gaskets are to be replaced as a matter of principle.

The components are to be cleaned and checked for wear before installation. Damaged or worn parts must be replaced with original spare parts.

Location points are to be coated with graphite or something similar before installation.

**DANGER! Risk of fatal injury!**

Risk of fatal injury and risk of injuries to personnel and property damage due to improper handling.

- The safety instructions and regulations according to chapter 2 "Safety" on page 55 and section 9.1 "Safety" on page 78 are to be taken into consideration for all maintenance and repair work.

9.6.1 Installation of Wilo-CronoNorm-NL

Shaft/bearing bracket

For shaft, see Fig. 23:

- Insert support disks (4.4) (only for bearing size 25) and roller bearings (4.1A and 4.1B) on the shaft.

For bearing bracket, see Fig. 22:

- Push shaft in the bearing bracket.
- Fasten the bearing cover (6) with hexagon head bolts (16).
- Insert V seals (4.3) and push the thrower (4.2) onto the shaft.
- Insert the key (3.3).

See Fig. 18:

- Insert the key (3.2).

Version with mechanical seal

For version with the mechanical seal, see Fig. 19:

- Clean the counter ring seat in the housing cover.
- Insert the stationary part of the mechanical seal (9.1) carefully into the housing cover (10).
- Screw the housing cover (10) onto the bearing bracket with the internal hexagon head bolts (15).
- Push the rotating part of the mechanical seal (9.1) onto the shaft.
- Push the spacer ring (9.2) onto the shaft.

Version with stuffing box packing

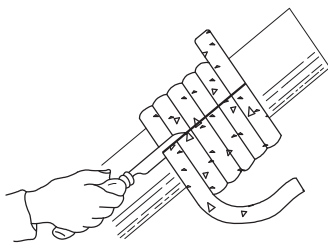

Fig. 29: Example for a straight cut

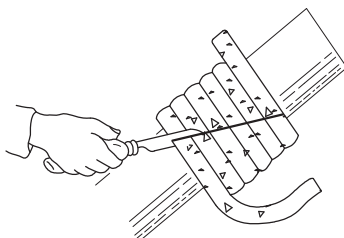

Fig. 30: Example for a diagonal cut

Version with stuffing box packing:

**CAUTION! Risk of damage to property!**

Danger of damage to the pump due to improper handling.

- Make sure that the tight fit is reached on the stuffing box housing and not on the sleeve.
- Check the surface of the shaft sleeve (see Fig. 21, item 11); many score marks are an indication that it must be replaced. Before installing, thoroughly clean all stuffing box parts.
If the packing is delivered in the form of a cord, this must be cut off.
- For this purpose, wind the packing helically around the shaft sleeve or around a clamping chuck of the same diameter.

**CAUTION! Risk of damage to property!**

Danger of damage to the stuffing box sleeve due to improper handling.

- Take suitable precautionary measures to avoid damaging the stuffing box sleeve.

This way, the required visible gap between the sleeve and packing ring is created during installation. For installation, pre-pressed graphite packing rings are to be cut in half by means of two diagonal cuts provided that the pump is not dismantled (see Fig. 29 / Fig. 30).

For version with the stuffing box packing, see Fig. 21:

- Push the shaft sleeve (11) onto the shaft.
- Insert the stuffing box housing (9.4) with seal (9.8) in the housing cover (10).
- Install one of the packing rings (9.1) in the stuffing box housing (9.4) and then

- insert the blocking ring (9.2) and the other packing rings, each offset by 180°.
- Fix the hexagon head bolts (9.5), bolts (9.6) and hex nuts (9.7), but don't tighten.
- Install the stuffing box sleeve (13) and the stuffing box gland (12).
- Fix the disk (9.9) and the other hex nuts (9.7).
- Tighten the nuts by hand. The packing rings must not yet be pressed together. After installation, the shaft should be able to be turned by hand.
- Screw the housing cover (10) onto the bearing bracket with the internal hexagon head bolts (15).

Slide-in unit

For the slide-in unit, see Fig. 18:

- Mount the impeller (2.1) with impeller nut (2.2) on the shaft.
- Mount the protective screen (7.1) with hexagon head bolts (7.2).

See Fig. 17:

- Insert a new housing seal (1.2).
- Carefully insert the slide-in unit into the spiral housing (1.1) and tighten with the hexagon head bolts (14).

See Fig. 22:

- Fasten the pump base (8.1) with the hexagon head bolt (8.2) and safety disk (8.3).

9.6.2 Installation of Wilo-CronoNorm-NLG

Bearing bracket

For bearing bracket, see Fig. 28:

- Press the roller bearings (6.1 and 6.2) onto the shaft (3.1).
- Push the shaft from the motor side toward the pump side in the bearing bracket until the bearing on the pump side is in the bearing bracket. For this, when hammering down, place a piece of wood between the bearing bracket and the bearing on the motor side to protect the bearing on the motor side.
- Insert a circlip (6.3) in the bearing bracket using circlip pliers.
- Push the shaft further into the bearing bracket. While doing so, push the circlip into position with the bearing on the motor side until you hear it snap into the groove in the bearing bracket.
- Fasten the bearing cover (10) with hexagon head bolts (14).
- Push the thrower (6.8) onto the shaft.
- Insert the inner and outer spacer rings (6.4 and 6.5), if present.
- Insert the spring disk (6.6) and mount the lock nut (6.7).
- Fasten the bearing cover (11) with hexagon head bolts (15).
- Insert the key (3.3).
- Fasten the pump base (8.1) with washer (8.3), spring disk (8.4) and the hexagon head bolt (8.2).

Version with mechanical seal

For version with the mechanical seal, see Fig. 26:

- Insert a new O-ring (5.12) in the cleaned mechanical seal cover (5.4).
- Insert the stationary part of the mechanical seal (5.11) into the cleaned mechanical seal cover (5.4).
- Push the mechanical seal cover (5.4) onto the shaft (3.1).
- Push the rotating part of the mechanical seal (5.11) onto the shaft.
- Push the fixing ring (5.3) onto the shaft and mount under the observation of the installation dimension H1 and the tightening torque (see Fig. 31 and Tab. 9).

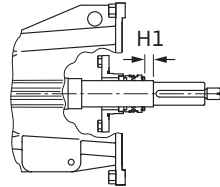

Fig. 31: Version with mechanical seal

Pump type/size	Installation dimension H1 [mm]	Tightening torque [Nm]
NLG 150/200	12	2.5
NLG 200/260	69	
NLG 200/315	16.5	
NLG 200/400	9	
NLG 200/450	9	
NLG 250/315	69.5	
NLG 250/355	12	
NLG 250/400	72	
NLG 300/400	72	

Tab. 9: Tightening torque

- Screw the housing cover 4.1 (drilled rinsing hole in the cover, aligned downward) to the bearing bracket (9) with hexagon head bolts (13).
- Screw the mechanical seal cover (5.4) to the housing cover (4.1) with hexagon head bolts (5.5).

See Fig. 26:

- Push the spacer ring (5.2) onto the shaft.

Version with stuffing box packing

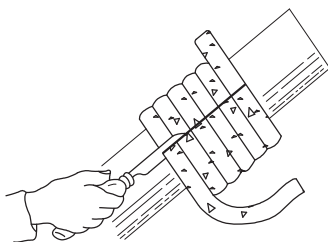

Fig. 32: Example for a straight cut

Version with stuffing box packing:



CAUTION! Risk of damage to property!

Danger of damage to the pump due to improper handling.

- **Make sure that the tight fit is reached on the stuffing box housing and not on the sleeve.**
- Check the surface of the shaft sleeve (see Fig. 27, item 5.12); many score marks are an indication that it must be replaced. Before installing, thoroughly clean all stuffing box parts.

If the packing is delivered in the form of a cord, this must be cut off.

- For this purpose, wind the packing helically around the shaft sleeve or around a clamping chuck of the same diameter.

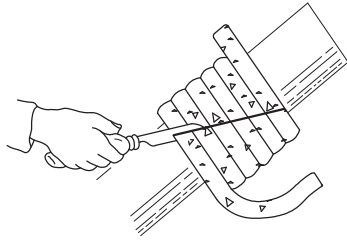

Fig. 33: Example for a diagonal cut



CAUTION! Risk of damage to property!

Danger of damage to the stuffing box sleeve due to improper handling.

- Take suitable precautionary measures to avoid damaging the stuffing box sleeve.

This way, the required visible gap between the sleeve and packing ring is established during installation. For installation, pre-pressed graphite packing rings are to be cut in half by means of two diagonal cuts provided that the pump is not dismantled (see Fig. 32 / Fig. 33).

See Fig. 27:

- Push the stuffing box gland (5.4) onto the shaft (3.1).
- Insert O-ring (5.13) in the shaft sleeve (5.12).
- Push the shaft sleeve (5.12) onto the shaft.
- Push the blocking ring (5.3) onto the shaft.
- Place the housing cover (4.1) on the bearing bracket (9) and fasten with the hexagon head bolts (13).
- Insert three packing rings (5.11) in the housing cover (4.1) and push the blocking ring (5.3) into the pressure cover.
- Insert other packing rings (5.11) in the housing cover.
- After inserting the last packing ring, secure the packing with the stuffing box gland (5.4). Tighten the hexagon head bolts (5.5) by hand.
- The packing rings must not yet be pressed together. After installation, the shaft should be able to be turned easily by hand.

Slide-in unit

For the slide-in unit, see Fig. 25:

- Mount the impeller (2.1) with impeller nut (2.2) on the shaft.
- Carefully insert the slide-in unit into the spiral housing (1.1) and tighten with the hexagon head bolts (12).
- Mount the protective screen (7.1) with hexagon head bolts (7.2).

9.7 Screw tightening torques

Screw tightening torques:

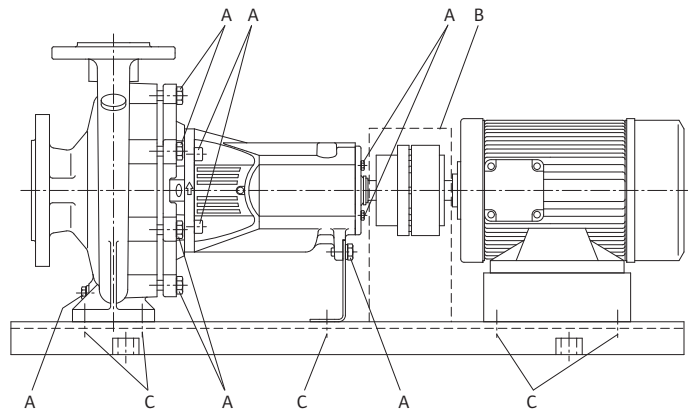

Fig. 34: Screw tightening torques

9.7.1 Screw tightening torques Wilo-CronoNorm-NL

When tightening the screws, use the following tightening torques.

- A (pump):

Thread:	M8	M10	M12	M16	M20	M24	M30	M36
Tightening torque [Nm]	12	25	40	90	175	300	500	700

Tab. 10: CronoNorm-NL - Screw tightening torque A (pump)

- B (coupling):
see Tab. 6 in section 7.5.2 "Check the coupling alignment" on page 71.
- C (baseplate):
see Tab. 7 in section 7.5.3 "Alignment of the pump unit" on page 72.

9.7.2 Screw tightening torques Wilo-CronoNorm-NLG

When tightening the screws, use the following tightening torques.

- A (pump):

Thread:	M6	M8	M10	M12	M16	M20	M24	M27	M30	M33	M36	M39
Tightening torque [Nm]	10.5	26	51	89	215	420	725	1070	1450	1970	2530	3290

Tab. 11: CronoNorm-NLG - Screw tightening torque A (pump)

- B (coupling):
see Tab. 6 in section 7.5.2 "Check the coupling alignment" on page 71.
- C (baseplate):
see Tab. 7 in section 7.5.3 "Alignment of the pump unit" on page 72.

10 Faults, causes and remedies

Have faults remedied by qualified personnel only! Observe the safety instructions in chapter 9 "Maintenance/repair" on page 78.

- If the malfunction cannot be rectified, consult a specialist technician or the nearest customer service or representative office.

10.1 Faults

The following error types can occur (see Tab. 12):

Error type	Explanation
1	Delivery rate too low
2	Motor overloaded
3	Pump end pressure too high
4	Bearing temperature too high
5	Leakage on the pump housing
6	Shaft seal leakage
7	Pump doesn't run smoothly or is loud
8	Pump temperature too high

Tab. 12: Error types

English

10.2 Causes and remedies

Error type:									Cause	Remedy
1	2	3	4	5	6	7	8			
X									Counter pressure too high	<ul style="list-style-type: none"> • Check system for contaminants • Reset the duty point
X							X	X	Pump and/or piping not completely filled	<ul style="list-style-type: none"> • Bleed pump and fill suction line
X							X	X	Inlet pressure too low or suction head too high	<ul style="list-style-type: none"> • Correct the fluid level • Minimize resistances in the suction line • Clean filter • Reduce suction head by installing the pump lower
X	X				X				Sealing gap too large due to wear	<ul style="list-style-type: none"> • Exchange worn stationary wear ring
X									Incorrect direction of rotation	<ul style="list-style-type: none"> • Change the motor connection phases
X									Pump is suctioning air or the suction line is leaky	<ul style="list-style-type: none"> • Replace seal • Check suction line
X									Supply line or impeller clogged	<ul style="list-style-type: none"> • Remove clog
X	X								Pump blocked by loose or jammed parts	<ul style="list-style-type: none"> • Clean pump
X									Air enclosures in the piping	<ul style="list-style-type: none"> • Change the pipe layout or install a bleed valve
X									Speed too low <ul style="list-style-type: none"> • with frequency converter operation • without frequency converter operation 	<ul style="list-style-type: none"> • Increase frequency in the permissible range • Check voltage
X	X								Motor running on 2 phases	<ul style="list-style-type: none"> • Check phases and fuses
	X						X		Counter pressure of the pump too low	<ul style="list-style-type: none"> • Readjust the duty point or adjust the impeller
	X								The viscosity or density of the fluid is higher than the design value	<ul style="list-style-type: none"> • Check the pump dimensioning (consult with the manufacturer)
	X		X		X	X	X		Pump is stressed or the stuffing box gland is inclined or tightened too tightly	<ul style="list-style-type: none"> • Correct the pump installation
	X	X							Speed too high	<ul style="list-style-type: none"> • Lower speed
			X		X	X			Pump unit poorly aligned	<ul style="list-style-type: none"> • Correct alignment
			X						Thrust too high	<ul style="list-style-type: none"> • Clean the relief bores in the impeller • Check the condition of the stationary wear rings
			X						Bearing lubrication not sufficient	<ul style="list-style-type: none"> • Check bearing, exchange bearing
			X						Coupling distance not maintained	<ul style="list-style-type: none"> • Correct the coupling distance
			X			X	X		Flow rate too low	<ul style="list-style-type: none"> • Maintain recommended minimum flow rate
				X					Housing screws not correctly tightened or seal defective	<ul style="list-style-type: none"> • Check tightening torque • Replace seal
					X				Mechanical seal / stuffing box leaky	<ul style="list-style-type: none"> • Replace the mechanical seal • Tighten the stuffing box or repack
					X				Shaft sleeve (if present) worn	<ul style="list-style-type: none"> • Replace the shaft sleeve • Repack the stuffing box
					X	X			Imbalance of the impeller	<ul style="list-style-type: none"> • Rebalance the impeller

Error type:								Cause	Remedy
1	2	3	4	5	6	7	8		
						X		Bearing damage	• Exchange bearing
						X		Foreign matter in the pump	• Clean pump
							X	Pump pumps against closed check valve	• Open the check valve in the pressure pipe

Tab. 13: Causes of error and remedies

11 Spare parts

Spare parts may be ordered via a local specialist retailer and/or Wilo after-sales service.

In order to avoid queries and incorrect orders, all data on the rating plate should be submitted for each order.



CAUTION! Risk of damage to property!

Trouble-free pump operation can only be guaranteed when original spare parts are used.

- Only use original Wilo spare parts.
- Information necessary when ordering spare parts:
 - Spare part numbers
 - Spare part designations
 - All data of the pump rating plate



NOTE:

List of genuine spare parts: See Wilo spare parts documentation and general drawings in the following sections:

- Section 11.1 "Spare parts lists, Wilo-CronoNorm-NL" on page 93 or
- Section 11.2 "Spare parts lists, Wilo-CronoNorm-NLG" on page 97.

English

11.1 Spare parts lists, Wilo-CronoNorm-NL

11.1.1 Wilo-CronoNorm-NL version with mechanical seal

For a list of spare parts, see Tab. 14.

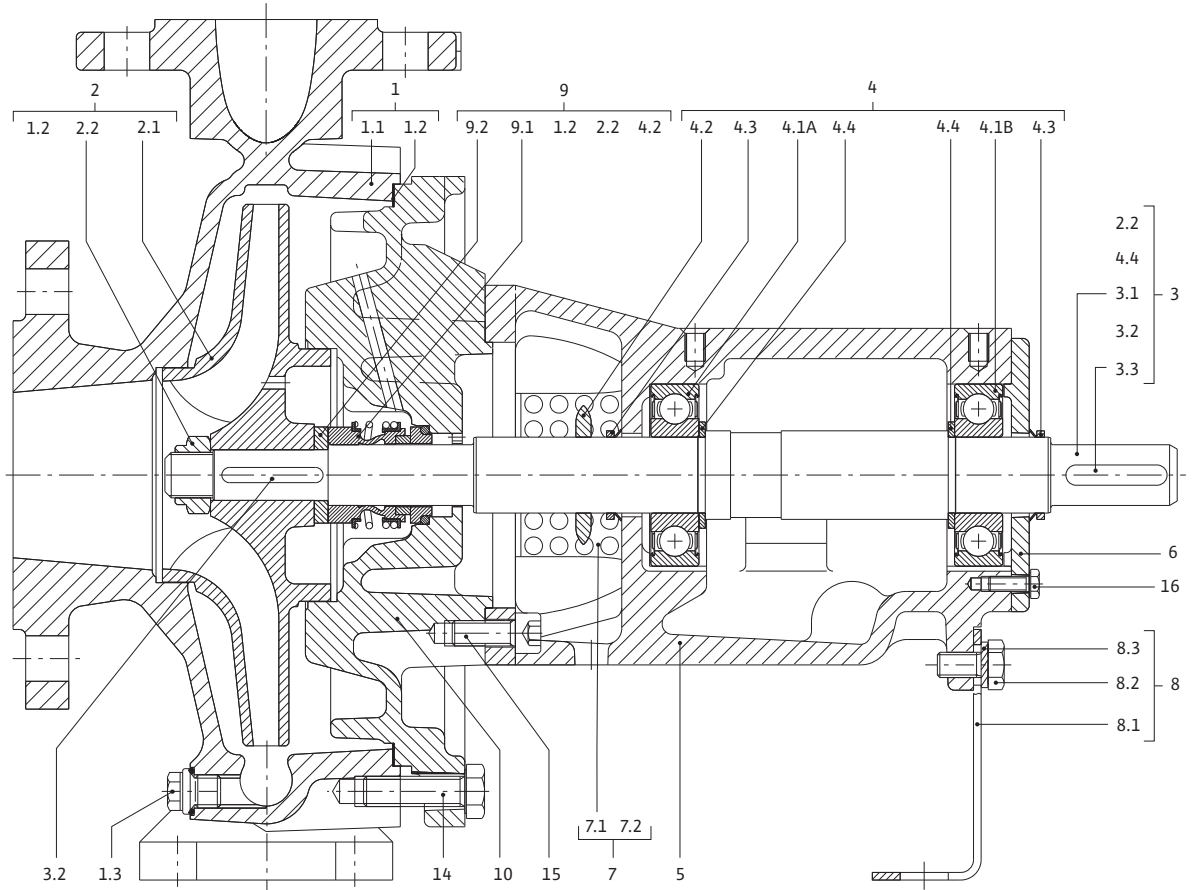

Fig. 35: Wilo-CronoNorm-NL version with mechanical seal

Item No.	Description	Quantity	Safety-relevant spare part
1.1	Spiral housing	1	
1.2	Housing seal	1	X
1.3	Housing plug	1	
2.1	Impeller	1	
2.2	Impeller nut	1	
3.1	Shaft	1	
3.2	Key	1	
3.3	Key	1	
4.1A	Roller bearing, on pump side	1	X
4.1B	Roller bearing, on the motor side	1	X
4.2	Thrower	1	
4.3	V-seal	2	
4.4	Support disk	2	
5	Bearing bracket	1	
6	Bearing cover	1	
7.1	Protective screen	2	
7.2	Hexagon head bolt	2	
8.1	Pump base	1	
8.2	Hexagon head bolt	1	
8.3	Safety disk	1	
9.1	Mechanical seal	1	X
9.2	Spacing ring	1	
10	Housing cover	1	
14	Hexagon head bolt	8	
15	Internal hexagon screw	4	
16	Hexagon head bolt	4	

Tab. 14: Spare parts list, Wilo-Crononorm-NL, version with mechanical seal

English

11.1.2 Wilo-CronoNorm-NL version with stuffing box packing

For a list of spare parts, see Tab. 15.

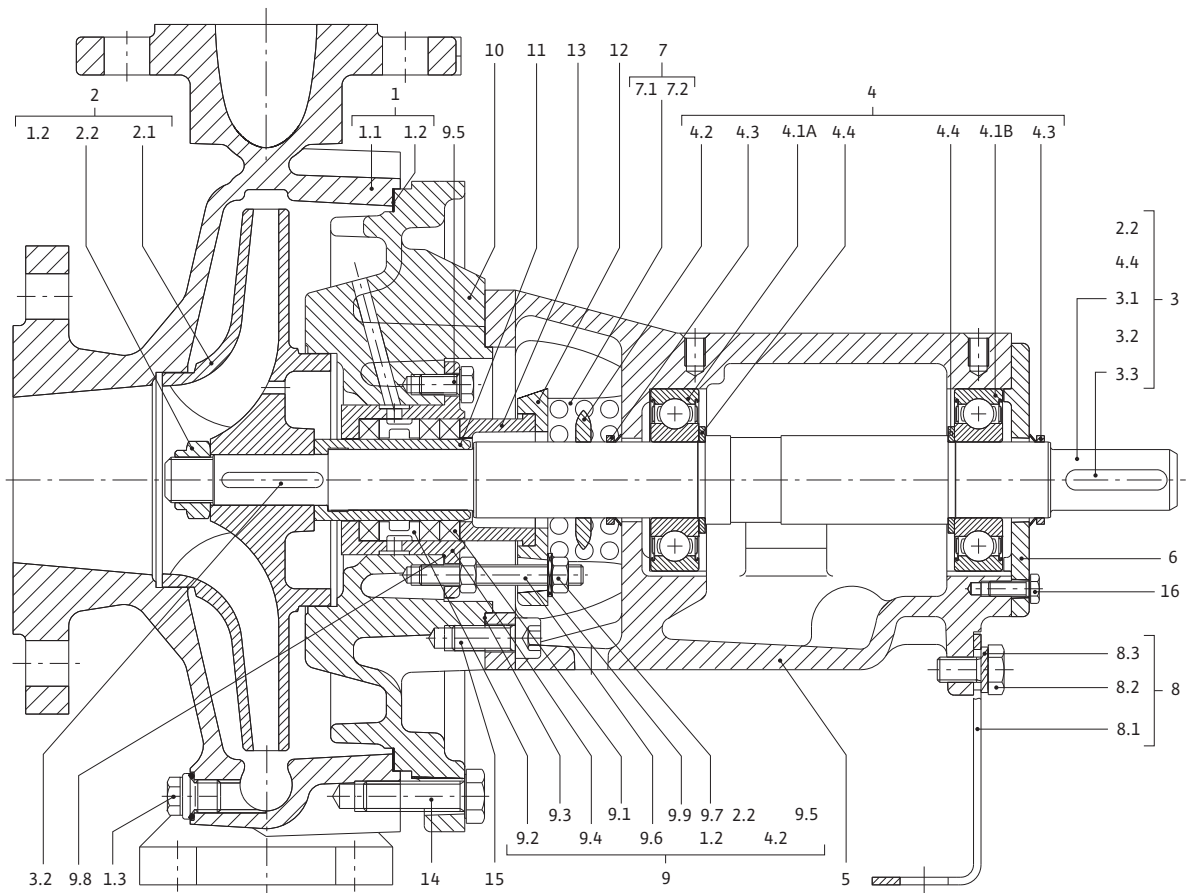

Fig. 36: Wilo-CronoNorm-NL version with stuffing box packing

Item No.	Description	Quantity	Safety-relevant spare part
1.1	Spiral housing	1	
1.2	Housing seal	1	X
1.3	Housing plug	1	
2.1	Impeller	1	
2.2	Impeller nut	1	
3.1	Shaft	1	
3.2	Key	1	
3.3	Key	1	
4.1A	Roller bearing, on pump side	1	X
4.1B	Roller bearing, on the motor side	1	X
4.2	Thrower	1	
4.3	V-seal	2	
4.4	Support disk	2	
5	Bearing bracket	1	
6	Bearing cover	1	
7.1	Protective screen	2	
7.2	Hexagon head bolt	2	
8.1	Pump base	1	
8.2	Hexagon head bolt	1	
8.3	Safety disk	1	
9.1	Packing rings	1	X
9.2	Blocking ring	1	
9.4	Stuffing box housing	1	
9.5	Hexagon head bolt	2	
9.6	Bolt	2	
9.7	Hexagon nut	2	
9.8	Seal	1	X
9.9	Washer	2	
10	Housing cover	1	
11	Shaft sleeve	1	
12	Stuffing box gland	1	
13	Stuffing box sleeve	1	
14	Hexagon head bolt	8	
15	Internal hexagon screw	4	
16	Hexagon head bolt	4	

Tab. 15: Spare parts list, Wilo-Crononorm-NL, version with stuffing box packing

English

11.2 Spare parts lists, Wilo-CronoNorm-NLG

11.2.1 Wilo-CronoNorm-NLG version with mechanical seal

For a list of spare parts, see Tab. 16.

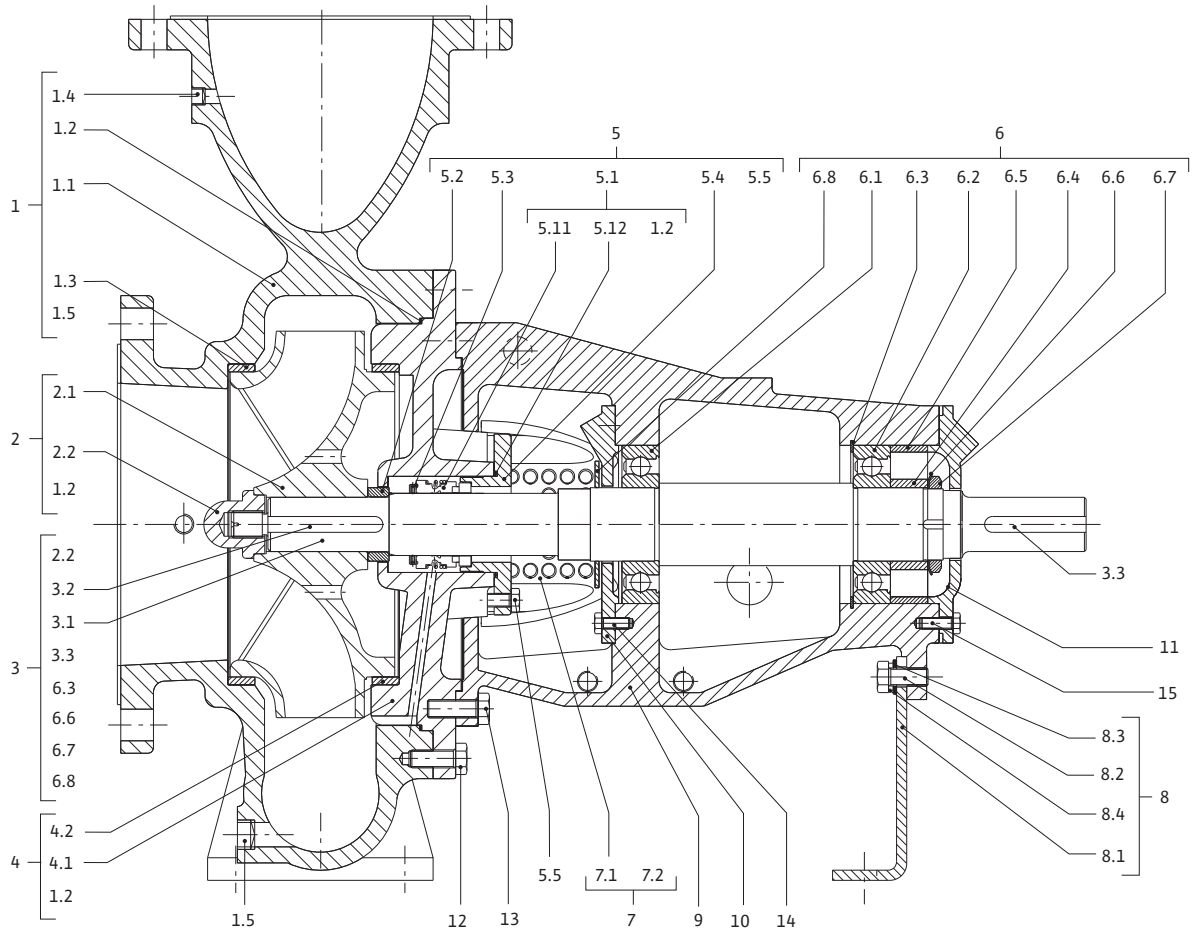

Fig. 37: Wilo-CronoNorm-NLG version with mechanical seal

Item No.	Description	Quantity	Safety-relevant spare part
1.1	Spiral housing	1	
1.2	O-ring	1	X
1.3	Stationary wear ring	1	
1.4	Venting screw	1	
1.5	Drain plug	1	
2.1	Impeller	1	
2.1	Impeller nut	1	
3.1	Shaft	1	
3.2	Key, on the motor side	1	
3.3	Key, on pump side	1	
4.1	Housing cover	1	
4.2	Stationary wear ring	1	
5.2	Spacing ring	1	
5.3	Fixing ring	1	
5.4	Mechanical seal cover	1	
5.5	Hexagon head bolt	4	Mechanical seal
5.11	Mechanical seal	1	X
5.12	O-ring	1	
6.1	Roller bearing, on pump side	1	X
6.2	Roller bearing, on the motor side	1	X
6.3	Circlip	1	
6.4	Spacer ring, internal	1	
6.5	Spacer ring, external	1	
6.6	Spring disk	1	
6.7	Lock nut	1	
6.8	Thrower	1	
7.1	Protective screen	2	
7.2	Hexagon head bolt	2	
8.1	Pump base	1	
8.2	Hexagon head bolt	1	Foot
8.3	Washer	1	
8.4	Spring disk	1	
9	Bearing bracket	1	
10	Bearing cover, on pump side	1	
11	Bearing cover, on the motor side	1	
12	Hexagon head bolt	12/16	Housing
13	Hexagon head bolt	12	Bearing bracket
14	Hexagon head bolt	4/6	Bearing, on pump side
15	Hexagon head bolt	4/6	Bearing, on the motor side

Tab. 16: Spare parts list, Wilo-Crononorm-NLG, version with mechanical seal

English

11.2.2 Wilo-CronoNorm-NLG version with stuffing box packing

For a list of spare parts, see Tab. 17.

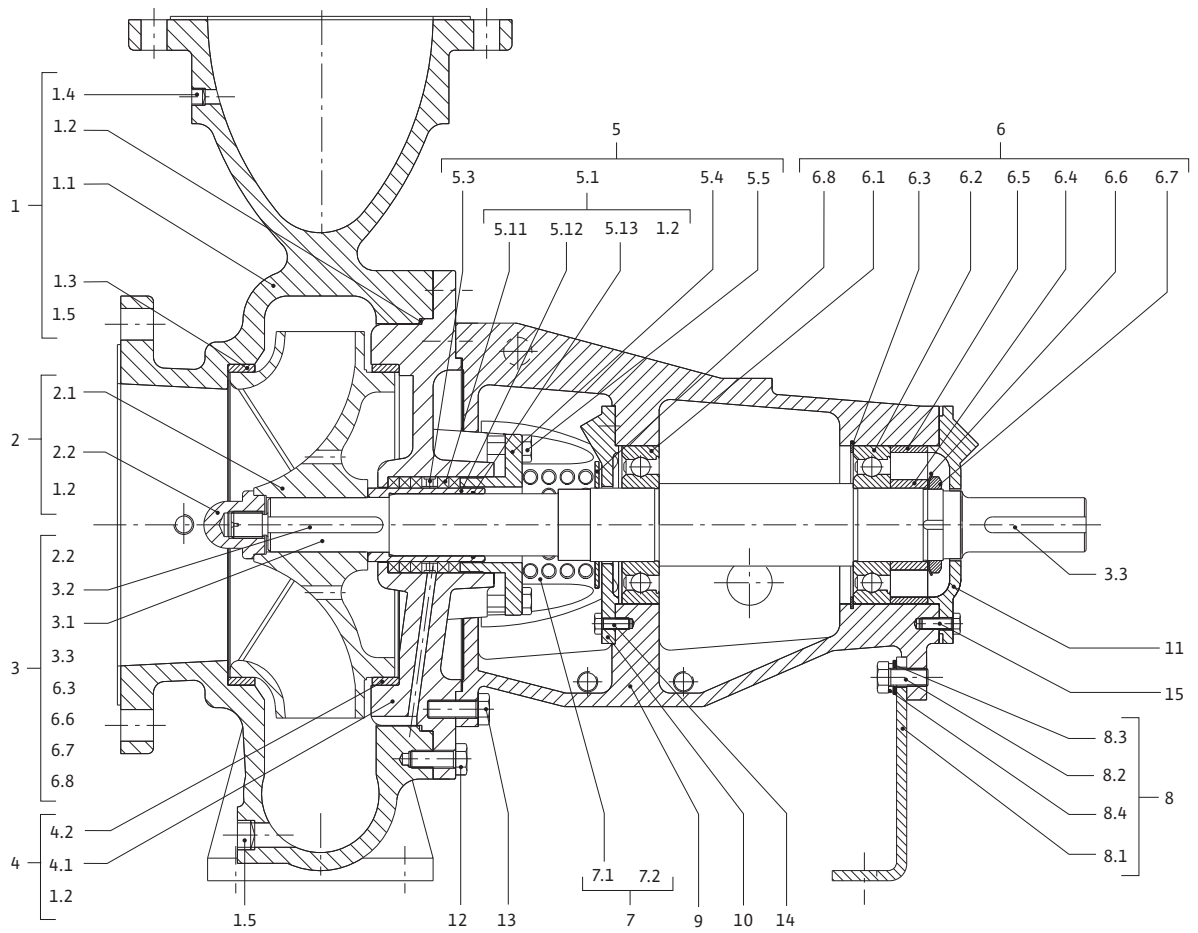

Fig. 38: Wilo-CronoNorm-NLG version with stuffing box packing

Item No.	Description	Quantity	Safety-relevant spare part
1.1	Spiral housing	1	
1.2	O-ring	1	X
1.3	Stationary wear ring	1	
1.4	Venting screw	1	
1.5	Drain plug	1	
2.1	Impeller	1	
2.2	Impeller nut	1	
3.1	Shaft	1	
3.2	Key, on pump side	1	
4.1	Housing cover	1	
4.2	Stationary wear ring	1	
5.3	Blocking ring	1	
5.4	Stuffing box gland	1	
5.5	Hexagon head bolt	4	Stuffing box gland
5.11	Packing	1	
5.12	Shaft sleeve	1	
5.13	O-ring	1	
6.1	Roller bearing, on pump side	1	X
6.2	Roller bearing, on the motor side	1	X
6.3	Circlip	1	
6.4	Spacer ring, internal	1	
6.5	Spacer ring, external	1	
6.6	Spring disk	1	
6.7	Lock nut	1	
6.8	Thrower	1	
7.1	Protective screen	2	
7.2	Hexagon head bolt	2	
8.1	Pump base	1	
8.2	Hexagon head bolt	1	Foot
8.3	Washer	1	
8.4	Spring disk	1	
9	Bearing bracket	1	
10	Bearing cover, on pump side	1	
11	Bearing cover, on the motor side	1	
12	Hexagon head bolt	12/16	Housing
13	Hexagon head bolt	12	Bearing bracket
14	Hexagon head bolt	4/6	Bearing, on pump side
15	Hexagon head bolt	4/6	Bearing, on the motor side

Tab. 17: Spare parts list, Wilo-Crononorm-NLG, version with mechanical seal

English

12 Disposal

Proper disposal and recycling of this product prevents damage to the environment and risks to personal health.

Proper disposal requires the drainage and cleaning (see chapter 9.4 “Draining and cleaning” on page 79) and the dismantling of the pump unit (see section 9.5 “Dismantling” on page 80).

Lubricants must be collected. The pump components are to be separated according to material (metal, plastic, electronics).

1. Use public or private disposal organisations when disposing of all or part of the product.
2. For more information on proper disposal, please contact your local council or waste disposal office or the supplier from whom you obtained the product.

Technical information subject to change without prior notice!

D EG – Konformitätserklärung
GB EC – Declaration of conformity
F Déclaration de conformité CE

(gemäß 2006/42/EG Anhang II,1A und 2004/108/EG Anhang IV,2,
according 2006/42/EC annex II,1A and 2004/108/EC annex IV,2,
conforme 2006/42/CE appendice II,1A et 2004/108/CE l'annexe IV,2)

Hiermit erklären wir, dass die Bauart der Baureihe : **NL**
Herewith, we declare that this pump type of the series:
Par le présent, nous déclarons que le type de pompes de la série:
(Die Seriennummer ist auf dem Typenschild des Produktes angegeben./
The serial number is marked on the product site plate./ Le numéro de série est inscrit sur la plaque signalétique du produit.)

in der gelieferten Ausführung folgenden einschlägigen Bestimmungen entspricht:
in its delivered state complies with the following relevant provisions:
est conforme aux dispositions suivantes dont il relève:

EG-Maschinenrichtlinie **2006/42/EG**
EC-Machinery directive
Directive CE relative aux machines

Die Schutzziele der Niederspannungsrichtlinie 2006/95/EG werden gemäß Anhang I, Nr. 1.5.1 der 2006/42/EG Maschinenrichtlinie eingehalten.
The protection objectives of the low-voltage directive 2006/95/EC are realized according annex I, No. 1.5.1 of the EC-Machinery directive 2006/42/EC.
Les objectifs de protection (sécurité) de la directive basse-tension 2006/95/CE sont respectés conformément à l'annexe I, n° 5.1 de la directive CE relatives aux machines 2006/42/CE.

Elektromagnetische Verträglichkeit - Richtlinie **2004/108/EG**
Electromagnetic compatibility - directive
Directive compatibilité électromagnétique

Richtlinie energieverbrauchsrelevanter Produkte **2009/125/EG**
Energy-related products - directive
Directive des produits liés à l'énergie

Die verwendeten 50Hz Induktionselektromotoren - Drehstrom, Käfigläufer, einstufig - entsprechen den Ökodesign - Anforderungen der Verordnung 640/2009 und der Verordnung 547/2012 von Wasserpumpen.
This applies according to eco-design requirements of the regulation 640/2009 to the versions with an induction electric motor, squirrel cage, three-phase, single speed, running at 50 Hz and of the regulation 547/2012 for water pumps.
Qui s'applique suivant les exigences d'éco-conception du règlement 640/2009 aux versions comportant un moteur électrique à induction à cage d'écreuil, triphasé, mono-vitesse, fonctionnant à 50 Hz et, du règlement 547/2012 pour les pompes à eau,

und entsprechender nationaler Gesetzgebung,
and with the relevant national legislation,
et aux législations nationales les transposant,

angewendete harmonisierte Normen, insbesondere:
as well as following harmonized standards:
ainsi qu'aux normes (européennes) harmonisées suivantes:

EN 809+A1
EN 60034-1

Bevollmächtigter für die Zusammenstellung der technischen Unterlagen ist:
Authorized representative for the completion of the technical documentation:
Personne autorisée à constituer le dossier technique est:

WILO SE
Division Pumps & Systems
PBU Pumps - Quality
Nortkirchenstraße 100
44263 Dortmund
Germany

Dortmund, 15. Januar 2013



Holger Herchenhein
Group Quality Manager



WILO SE
Nortkirchenstraße 100
44263 Dortmund
Germany

D EG – Konformitätserklärung
GB EC – Declaration of conformity
F Déclaration de conformité CE

(gemäß 2006/42/EG Anhang II,1A und 2004/108/EG Anhang IV,2,
according 2006/42/EC annex II,1A and 2004/108/EC annex IV,2,
conforme 2006/42/CE appendice II,1A et 2004/108/CE l'annexe IV,2)

Hiermit erklären wir, dass die Bauart der Baureihe : **NLG**

Herewith, we declare that this pump type of the series:

Par le présent, nous déclarons que le type de pompes de la série:

(Die Seriennummer ist auf dem Typenschild des Produktes angegeben./

The serial number is marked on the product site plate./ Le numéro de série est inscrit sur la plaque signalétique du produit.)

in der gelieferten Ausführung folgenden einschlägigen Bestimmungen entspricht:

in its delivered state complies with the following relevant provisions:

est conforme aux dispositions suivantes dont il relève:

EG-Maschinenrichtlinie

2006/42/EG

EC-Machinery directive

Directive CE relative aux machines

Die Schutzziele der Niederspannungsrichtlinie 2006/95/EG werden gemäß Anhang I, Nr. 1.5.1 der 2006/42/EG Maschinenrichtlinie eingehalten.

The protection objectives of the low-voltage directive 2006/95/EC are realized according annex I, No. 1.5.1 of the EC-Machinery directive 2006/42/EC.

Les objectifs de protection (sécurité) de la directive basse-tension 2006/95/CE sont respectés conformément à l'annexe I, n° 5.1 de la directive CE relatives aux machines 2006/42/CE.

Elektromagnetische Verträglichkeit - Richtlinie

2004/108/EG

Electromagnetic compatibility - directive

Directive compatibilité électromagnétique

Richtlinie energieverbrauchsrelevanter Produkte

2009/125/EG

Energy-related products - directive

Directive des produits liés à l'énergie

Die verwendeten 50Hz Induktionselektromotoren - Drehstrom, Käfigläufer, einstufig - entsprechen den Ökodesign - Anforderungen der Verordnung 640/2009 und der Verordnung 547/2012 von Wasserpumpen.

This applies according to eco-design requirements of the regulation 640/2009 to the versions with an induction electric motor, squirrel cage, three-phase, single speed, running at 50 Hz and of the regulation 547/2012 for water pumps.

Qui s'applique suivant les exigences d'éco-conception du règlement 640/2009 aux versions comportant un moteur électrique à induction à cage d'écoreuil, triphasé, mono-vitesse, fonctionnant à 50 Hz et, du règlement 547/2012 pour les pompes à eau,

und entsprechender nationaler Gesetzgebung,

and with the relevant national legislation,

et aux législations nationales les transposant,

angewendete harmonisierte Normen, insbesondere:

EN 809+A1

as well as following harmonized standards:

EN 60034-1

ainsi qu'aux normes (européennes) harmonisées suivantes:

Bevollmächtigter für die Zusammenstellung der technischen Unterlagen ist:

Authorized representative for the completion of the technical documentation:

Personne autorisée à constituer le dossier technique est:

WILO SE
Division Pumps & Systems
PBU Pumps - Quality
Nortkirchenstraße 100
44263 Dortmund
Germany

Dortmund, 15. Januar 2013



Holger Herchenhein
Group Quality Manager



WILO SE
Nortkirchenstraße 100
44263 Dortmund
Germany